

Control

HP-XQ (M3.7X-I)

099-00HPXQ-EW501

Observe additional system documents!

24.01.2024

**Register now  
and benefit!  
Jetzt Registrieren  
und Profitieren!**

[www.ewm-group.com](http://www.ewm-group.com)



# General instructions

## WARNING



### **Read the operating instructions!**

#### **The operating instructions provide an introduction to the safe use of the products.**

- Read and observe the operating instructions for all system components, especially the safety instructions and warning notices!
- Observe the accident prevention regulations and any regional regulations!
- The operating instructions must be kept at the location where the machine is operated.
- Safety and warning labels on the machine indicate any possible risks. Keep these labels clean and legible at all times.
- The machine has been constructed to state-of-the-art standards in line with any applicable regulations and industrial standards. Only trained personnel may operate, service and repair the machine.
- Technical changes due to further development in machine technology may lead to a differing welding behaviour.

**In the event of queries on installation, commissioning, operation or special conditions at the installation site, or on usage, please contact your sales partner or our customer service department on +49 2680 181-0.**

**A list of authorised sales partners can be found at [www.ewm-group.com/en/specialist-dealers](http://www.ewm-group.com/en/specialist-dealers).**

Liability relating to the operation of this equipment is restricted solely to the function of the equipment. No other form of liability, regardless of type, shall be accepted. This exclusion of liability shall be deemed accepted by the user on commissioning the equipment.

The manufacturer is unable to monitor whether or not these instructions or the conditions and methods are observed during installation, operation, usage and maintenance of the equipment.

An incorrectly performed installation can result in material damage and injure persons as a result. For this reason, we do not accept any responsibility or liability for losses, damages or costs arising from incorrect installation, improper operation or incorrect usage and maintenance or any actions connected to this in any way.

© EWM GmbH

Dr. Günter-Henle-Strasse 8

56271 Mündersbach Germany

Tel.: +49 2680 181-0, Fax: -244

Email: [info@ewm-group.com](mailto:info@ewm-group.com)

[www.ewm-group.com](http://www.ewm-group.com)

The copyright to this document remains the property of the manufacturer.

Copying, including extracts, only permitted with written approval.

The content of this document has been prepared and reviewed with all reasonable care. The information provided is subject to change; errors excepted.

### **Data security**

The user is responsible for backing up data of all changes from the factory setting. The user is liable for erased personal settings. The manufacturer does not assume any liability for this.

# 1 Contents

<b>1</b>	<b>Contents</b> .....	<b>3</b>
<b>2</b>	<b>For your safety</b> .....	<b>6</b>
2.1	Notes on using these operating instructions.....	6
2.2	Explanation of icons.....	7
2.3	Safety instructions.....	8
2.4	Transport and installation .....	11
<b>3</b>	<b>Intended use</b> .....	<b>13</b>
3.1	Use and operation solely with the following machines .....	13
3.2	Software version .....	13
3.3	Documents which also apply .....	13
3.4	Part of the complete documentation .....	14
<b>4</b>	<b>Machine control – Operating elements</b> .....	<b>15</b>
4.1	Overview of control sections .....	15
4.1.1	Control section A .....	16
4.1.2	Control section B .....	17
4.1.3	Control section C .....	18
4.2	Welding data display.....	20
4.3	Operating the machine control.....	21
4.3.1	Main screen .....	21
4.3.2	Welding power setting .....	21
4.3.3	Welding parameter setting in the operation sequence.....	21
4.3.4	Setting advanced welding parameters (Expert menu) .....	22
4.3.5	Changing basic settings (machine configuration menu) .....	22
4.3.6	Lock function .....	22
<b>5</b>	<b>Functional characteristics</b> .....	<b>23</b>
5.1	Shielding gas volume settings .....	23
5.1.1	Gas test .....	23
5.1.2	Purge hose package.....	24
5.2	Wire inching .....	24
5.3	Wire return .....	25
5.4	MIG/MAG welding.....	26
5.4.1	Welding task selection.....	26
5.4.2	Basic welding parameters .....	26
5.4.2.1	Welding procedure .....	27
5.4.2.2	Operating mode .....	27
5.4.2.3	Welding type .....	28
5.4.3	Welding power (operating point) .....	29
5.4.3.1	Accessory components for operating point setting .....	29
5.4.3.2	Arc length .....	30
5.4.3.3	Arc dynamics (choke effect).....	30
5.4.3.4	superPuls .....	31
5.4.3.5	Copy JOB (welding task) .....	32
5.4.4	Expert menu (MIG/MAG).....	33
5.4.4.1	Burn-back.....	34
5.4.4.2	Programme limit.....	35
5.4.5	Programs (P <sub>A</sub> 1-15) .....	35
5.4.5.1	Selection and adjustment.....	36
5.4.6	Program sequence .....	38
5.4.6.1	Selection .....	39
5.4.6.2	Setting .....	39
5.4.7	Operating modes (functional sequences) .....	40
5.4.7.1	Explanation of signs and functions .....	40
5.4.7.2	Automatic cut-out .....	40
5.4.8	forceArc / forceArc puls .....	53
5.4.9	wiredArc.....	54
5.4.10	rootArc/rootArc puls.....	54
5.4.11	coldArc / coldArc puls .....	55
5.4.12	Standard MIG/MAG torch.....	55

5.4.13	MIG/MAG special-torches.....	55
5.4.13.1	Program and up/down operation.....	55
5.4.13.2	Switching between Push/Pull and intermediate drive.....	56
5.5	TIG welding.....	56
5.5.1	Welding task selection.....	56
5.5.2	Welding current setting.....	56
5.5.3	Arc ignition.....	57
5.5.3.1	Liftarc.....	57
5.5.4	Operating modes (functional sequences).....	58
5.5.4.1	Explanation of signs and functions.....	58
5.5.4.2	Automatic cut-out.....	58
5.6	MMA welding.....	62
5.6.1	Welding task selection.....	62
5.6.2	Welding current setting.....	62
5.6.3	Arcforce.....	62
5.6.4	Hotstart.....	63
5.6.4.1	Hotstart current.....	63
5.6.4.2	Hotstart time.....	63
5.6.5	Antistick.....	63
5.7	Options (additional components).....	64
5.7.1	Electronic gas flow control (OW DGC).....	64
5.7.2	Wire reserve sensor (OW WRS).....	64
5.7.3	Wire spool heater (OW WHS).....	64
5.8	Access control.....	64
5.9	Voltage reducing device.....	64
5.10	Special parameters (advanced settings).....	64
5.10.1	Selecting, changing and saving parameters.....	65
5.10.2	Reset to factory settings.....	67
5.10.3	Special parameters in detail.....	67
5.10.3.1	Ramp time for wire inching (P1).....	67
5.10.3.2	Program "0", releasing the program block (P2).....	67
5.10.3.3	Display mode for Up/Down welding torch with one-digit 7-segment display (P3).....	68
5.10.3.4	Program limit (P4).....	68
5.10.3.5	Special cycle in the operating modes special latched and non-latched (P5).....	68
5.10.3.6	Correction operation, threshold value setting (P7).....	68
5.10.3.7	Switching programs with the standard torch trigger (P8).....	70
5.10.3.8	Latched/special-latched tap start (P9).....	71
5.10.3.9	"Single or dual operation" (P10) setting.....	71
5.10.3.10	Latched special tapping time setting (P11).....	71
5.10.3.11	JOB list switching (P12).....	72
5.10.3.12	Lower and upper limits of the remote JOB changeover process (P13, P14).....	72
5.10.3.13	Hold function (P15).....	72
5.10.3.14	Block JOB mode (P16).....	73
5.10.3.15	Selecting programs with the standard torch trigger (P17).....	73
5.10.3.16	Average value display for superPuls (P19).....	73
5.10.3.17	Predefined execution of the pulsed arc welding process in the PA program (P20).....	74
5.10.3.18	Predefined absolute value for relative programs (P21).....	74
5.10.3.19	Electronic gas flow control, type (P22).....	74
5.10.3.20	Program settings for relative programs (P23).....	74
5.10.3.21	Correction or nominal voltage display (P24).....	74
5.10.3.22	JOB selection in Expert mode (P25).....	74
5.10.3.23	Nominal value wire heater (P26).....	74
5.10.3.24	Mode switching at welding start (P27).....	74
5.10.3.25	Error threshold electronic gas flow control (P28).....	74
5.10.3.26	Units system (P29).....	74

---

5.10.3.27 Selection option – Program sequence with welding power rotary knob (P30) .....	75
5.11 Machine configuration menu.....	75
5.11.1 Selecting, changing and saving parameters .....	75
5.11.2 Aligning the cable resistance.....	76
5.12 Power-saving mode (Standby) .....	77
<b>6 Maintenance, care and disposal.....</b>	<b>78</b>
6.1 General .....	78
6.2 Disposing of equipment .....	79
<b>7 Rectifying faults .....</b>	<b>80</b>
7.1 Software version of the machine control .....	80
7.2 Error messages (power source) .....	80
7.3 Warnings.....	87
7.4 Resetting JOBs (welding tasks) to the factory settings .....	89
7.4.1 Resetting a single JOB .....	89
7.4.2 Resetting all JOBs.....	89
<b>8 Appendix.....</b>	<b>90</b>
8.1 JOB-List .....	90
8.2 Parameter overview – setting ranges .....	97
8.2.1 MIG/MAG welding .....	97
8.2.2 TIG welding .....	98
8.2.3 MMA welding .....	98
8.3 Searching for a dealer .....	99

## 2 For your safety

### 2.1 Notes on using these operating instructions

#### **DANGER**

**Working or operating procedures which must be closely observed to prevent imminent serious and even fatal injuries.**

- Safety notes include the "DANGER" keyword in the heading with a general warning symbol.
- The hazard is also highlighted using a symbol on the edge of the page.

#### **WARNING**

**Working or operating procedures which must be closely observed to prevent serious and even fatal injuries.**

- Safety notes include the "WARNING" keyword in the heading with a general warning symbol.
- The hazard is also highlighted using a symbol in the page margin.

#### **CAUTION**

**Working or operating procedures which must be closely observed to prevent possible minor personal injury.**

- The safety information includes the "CAUTION" keyword in its heading with a general warning symbol.
- The risk is explained using a symbol on the edge of the page.



**Technical aspects which the user must observe to avoid material or equipment damage.**

Instructions and lists detailing step-by-step actions for given situations can be recognised via bullet points, e.g.:

- Insert the welding current lead socket into the relevant socket and lock.

## 2.2 Explanation of icons

Symbol	Description	Symbol	Description
	Indicates technical aspects which the user must observe.		Activate and release / Tap / Tip
	Switch off machine		Release
	Switch on machine		Press and hold
	Incorrect / Invalid		Switch
	Correct / Valid		Turn
	Input		Numerical value – adjustable
	Navigation		Signal light lights up in green
	Output		Signal light flashes green
	Time representation (e.g.: wait 4 s / actuate)		Signal light lights up in red
	Interruption in the menu display (other setting options possible)		Signal light flashes red
	Tool not required/do not use		Signal light lights up in blue
	Tool required/use		Signal light flashes blue

## 2.3 Safety instructions

### **WARNING**



**Risk of accidents due to non-compliance with the safety instructions!**

**Non-compliance with the safety instructions can be fatal!**

- Carefully read the safety instructions in this manual!
- Observe the accident prevention regulations and any regional regulations!
- Inform persons in the working area that they must comply with the regulations!



**Risk of injury from electrical voltage!**

**Voltages can cause potentially fatal electric shocks and burns on contact. Even low voltages can cause a shock and lead to accidents.**

- Never touch live components such as welding current sockets or stick, tungsten or wire electrodes!
- Always place torches and electrode holders on an insulated surface!
- Wear the full personal protective equipment (depending on the application)!
- The machine may only be opened by qualified personnel!
- The device must not be used to defrost pipes!



**Hazard when interconnecting multiple power sources!**

**If a number of power sources are to be connected in parallel or in series, only a technical specialist may interconnect the sources as per standard IEC 60974-9:2010: Installation and use and German Accident Prevention Regulation BVG D1 (formerly VBG 15) or country-specific regulations.**

**Before commencing arc welding, a test must verify that the equipment cannot exceed the maximum permitted open circuit voltage.**

- Only qualified personnel may connect the machine.
- When taking individual power sources out of operation, all mains and welding current leads must be safely disconnected from the welding system as a whole. (Hazard due to reverse polarity voltage!)
- Do not interconnect welding machines with pole reversing switch (PWS series) or machines for AC welding since a minor error in operation can cause the welding voltages to be combined, which is not permitted.



**Risk of injury due to radiation or heat!**

**Arc radiation can lead to skin and eye injuries.**

**Contact with hot workpieces and sparks can lead to burns.**

- Use hand shield or welding helmet with the appropriate safety level (depends on the application).
- Wear dry protective clothing (e.g. hand shield, gloves, etc.) in accordance with the applicable regulations of your country.
- Persons who are not directly involved should be protected with a welding curtain or suitable safety screen against radiation and the risk of blinding!



 **WARNING****Risk of injury due to improper clothing!**

**During arc welding, radiation, heat and voltage are sources of risk that cannot be avoided. The user has to be equipped with the complete personal protective equipment at all times. The protective equipment has to include:**

- Respiratory protection against hazardous substances and mixtures (fumes and vapours); otherwise implement suitable measures such as extraction facilities.
- Welding helmet with proper protection against ionizing radiation (IR and UV radiation) and heat.
- Dry welding clothing (shoes, gloves and body protection) to protect against warm environments with conditions comparable to ambient temperatures of 100 °C or higher and arcing and work on live components.
- Hearing protection against harming noise.

**Explosion risk!**

**Apparently harmless substances in closed containers may generate excessive pressure when heated.**

- Move containers with inflammable or explosive liquids away from the working area!
- Never heat explosive liquids, dusts or gases by welding or cutting!

**Fire hazard!**

**Due to the high temperatures, sparks, glowing parts and hot slag that occur during welding, there is a risk of flames.**

- Be watchful of potential sources of fire in the working area!
- Do not carry any easily inflammable objects, e.g. matches or lighters.
- Ensure suitable fire extinguishers are available in the working area!
- Thoroughly remove any residue of flammable materials from the workpiece prior to starting to weld.
- Only further process workpieces after they have cooled down. Do not allow them to contact any flammable materials!

## ⚠ CAUTION



### Smoke and gases!

**Smoke and gases may lead to shortness of breath and poisoning! The ultraviolet radiation of the arc may also convert solvent vapours (chlorinated hydrocarbon) into poisonous phosgene.**

- Ensure sufficient fresh air!
- Keep solvent vapours away from the arc beam field!
- Wear suitable respiratory protection if necessary!
- To prevent the formation of phosgene, residues of chlorinated solvents on workpieces must first be neutralised using appropriate measures.



### Noise exposure!

**Noise exceeding 70 dBA can cause permanent hearing damage!**

- Wear suitable ear protection!
- Persons located within the working area must wear suitable ear protection!



**According to IEC 60974-10, welding machines are divided into two classes of electromagnetic compatibility (the EMC class can be found in the Technical data):**

**Class A** machines are not intended for use in residential areas where the power supply comes from the low-voltage public mains network. When ensuring the electromagnetic compatibility of class A machines, difficulties can arise in these areas due to interference not only in the supply lines but also in the form of radiated interference.



**Class B** machines fulfil the EMC requirements in industrial as well as residential areas, including residential areas connected to the low-voltage public mains network.



### Setting up and operating

When operating arc welding systems, in some cases, electro-magnetic interference can occur although all of the welding machines comply with the emission limits specified in the standard. The user is responsible for any interference caused by welding.

In order to **evaluate** any possible problems with electromagnetic compatibility in the surrounding area, the user must consider the following: (see also EN 60974-10 Appendix A)

- Mains, control, signal and telecommunication lines
- Radios and televisions
- Computers and other control systems
- Safety equipment
- The health of neighbouring persons, especially if they have a pacemaker or wear a hearing aid
- Calibration and measuring equipment
- The immunity to interference of other equipment in the surrounding area
- The time of day at which the welding work must be carried out

### Recommendations for **reducing interference emission**

- Mains connection, e.g. additional mains filter or shielding with a metal tube
- Maintenance of the arc welding system
- Welding leads should be as short as possible and run closely together along the ground
- Potential equalization
- Earthing of the workpiece. In cases where it is not possible to earth the workpiece directly, it should be connected by means of suitable capacitors.
- Shielding from other equipment in the surrounding area or the entire welding system



### Electromagnetic fields!

**The power source can create electrical or electromagnetic fields that may impair the function of electronic systems such as EDP and CNC devices, telecommunication, power and signal lines as well as pacemakers and defibrillators.**



- Follow the maintenance instructions > see 6 chapter!
- Unwind the welding leads completely!
- Shield radiation-sensitive equipment or facilities appropriately!
- The function of pacemakers may be impaired (seek medical advice if necessary).

**⚠ CAUTION****Obligations of the operator!**

**The respective national directives and laws must be complied with when operating the machine!**

- Implementation of national legislation relating to framework directive 89/391/EEC on the introduction of measures to encourage improvements in the safety and health of workers at work and associated individual guidelines.
- In particular, directive 89/655/EEC concerning the minimum safety and health requirements for the use of work equipment by workers at work.
- The regulations applicable to occupational safety and accident prevention in the country concerned.
- Setting up and operating the machine as per IEC 60974.-9.
- Brief the user on safety-conscious work practices on a regular basis.
- Regularly inspect the machine as per IEC 60974.-4.



***The manufacturer's warranty becomes void if non-genuine parts are used!***

- ***Only use system components and options (power sources, welding torches, electrode holders, remote controls, spare parts and replacement parts, etc.) from our range of products!***
- ***Only insert and lock accessory components into the relevant connection socket when the machine is switched off.***

**Requirements for connection to the public mains network**

High-performance machines can influence the mains quality by taking current from the mains network. For some types of machines, connection restrictions or requirements relating to the maximum possible line impedance or the necessary minimum supply capacity at the interface with the public network (Point of Common Coupling, PCC) can therefore apply. In this respect, attention is also drawn to the machines' technical data. In this case, it is the responsibility of the operator, where necessary in consultation with the mains network operator, to ensure that the machine can be connected.

## 2.4 Transport and installation

**⚠ WARNING****Risk of injury due to improper handling of shielding gas cylinders!**

**Improper handling and insufficient securing of shielding gas cylinders can cause serious injuries!**

- Observe the instructions from the gas manufacturer and any relevant regulations concerning the use of compressed air!
- Do not attach any element to the shielding gas cylinder valve!
- Prevent the shielding gas cylinder from heating up.

## CAUTION



### **Risk of accidents due to supply lines!**

**During transport, attached supply lines (mains leads, control cables, etc.) can cause risks, e.g. by causing connected machines to tip over and injure persons!**

- Disconnect all supply lines before transport!



### **Risk of tipping!**

**There is a risk of the machine tipping over and injuring persons or being damaged itself during movement and set up. Tilt resistance is guaranteed up to an angle of 10° (according to IEC 60974-1).**

- Set up and transport the machine on level, solid ground.
- Secure add-on parts using suitable equipment.



### **Risk of accidents due to incorrectly installed leads!**

**Incorrectly installed leads (mains, control and welding leads or intermediate hose packages ) can present a tripping hazard.**

- Lay the supply lines flat on the floor (avoid loops).
- Avoid laying the leads on passage ways.



### **Risk of injury from heated coolant and its connections!**

**The coolant used and its connection or connection points can heat up significantly during operation (water-cooled version). When opening the coolant circuit, escaping coolant may cause scalding.**

- Open the coolant circuit only when the power source or cooling unit is switched off!
- Wear proper protective equipment (protective gloves)!
- Seal open connections of the hose leads with suitable plugs.



***The units are designed for operation in an upright position!***

***Operation in non-permissible positions can cause equipment damage.***

- ***Only transport and operate in an upright position!***



***Accessory components and the power source itself can be damaged by incorrect connection!***

- ***Only insert and lock accessory components into the relevant connection socket when the machine is switched off.***
- ***Comprehensive descriptions can be found in the operating instructions for the relevant accessory components.***
- ***Accessory components are detected automatically after the power source is switched on.***



***Protective dust caps protect the connection sockets and therefore the machine against dirt and damage.***

- ***The protective dust cap must be fitted if there is no accessory component being operated on that connection.***
- ***The cap must be replaced if faulty or if lost!***

### 3 Intended use

#### WARNING



**Hazards due to improper usage!**

The machine has been constructed to the state of the art and any regulations and standards applicable for use in industry and trade. It may only be used for the welding procedures indicated at the rating plate. Hazards may arise for persons, animals and material objects if the equipment is not used correctly. No liability is accepted for any damages arising from improper usage!

- The equipment must only be used in line with its designated purpose and by trained or expert personnel!
- Do not improperly modify or convert the equipment!

#### 3.1 Use and operation solely with the following machines

This description may only be applied to machines with the M3.7X-I machine control.

#### 3.2 Software version

The software version of the machine control can be displayed in the machine configuration menu (menu Srv) > see 5.11 chapter.

#### 3.3 Documents which also apply

- Operating instructions for the connected welding machines
- Documents of the optional expansions

### 3.4 Part of the complete documentation

This document is part of the complete documentation and valid only in combination with all other parts of these instructions! Read and observe the operating instructions for all system components, especially the safety instructions!

The illustration shows a general example of a welding system.

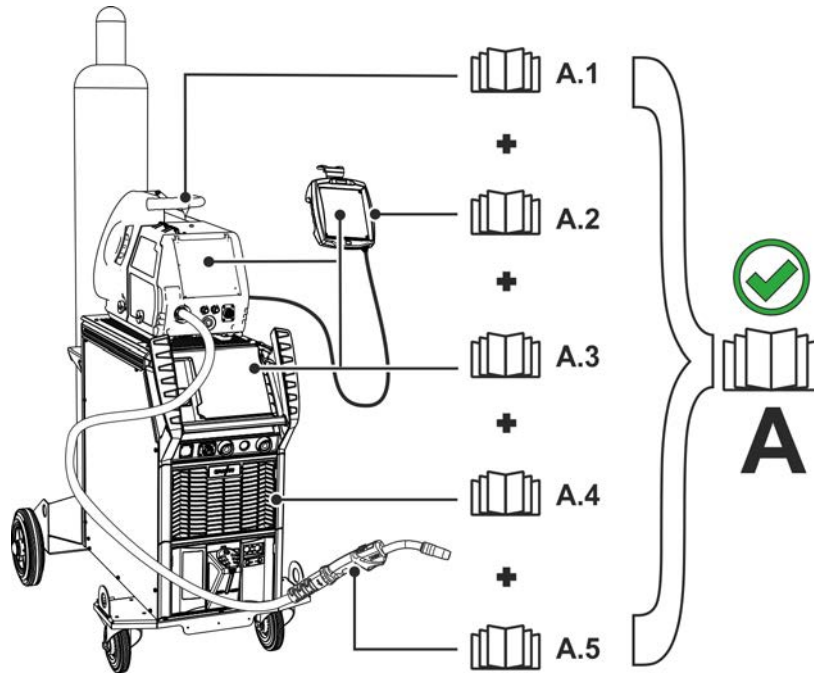

Figure 3-1

Item	Documentation
A.1	Wire feed unit
A.2	Remote control
A.3	Control
A.4	Power source
A.5	Welding torch
A	Complete documentation

## 4 Machine control – Operating elements

### 4.1 Overview of control sections

For description purposes, the machine control has been divided into three sections (A, B, C) to ensure maximum clarity. The setting range for the parameter values are summarised in the parameter overview section > see 8.2 chapter.

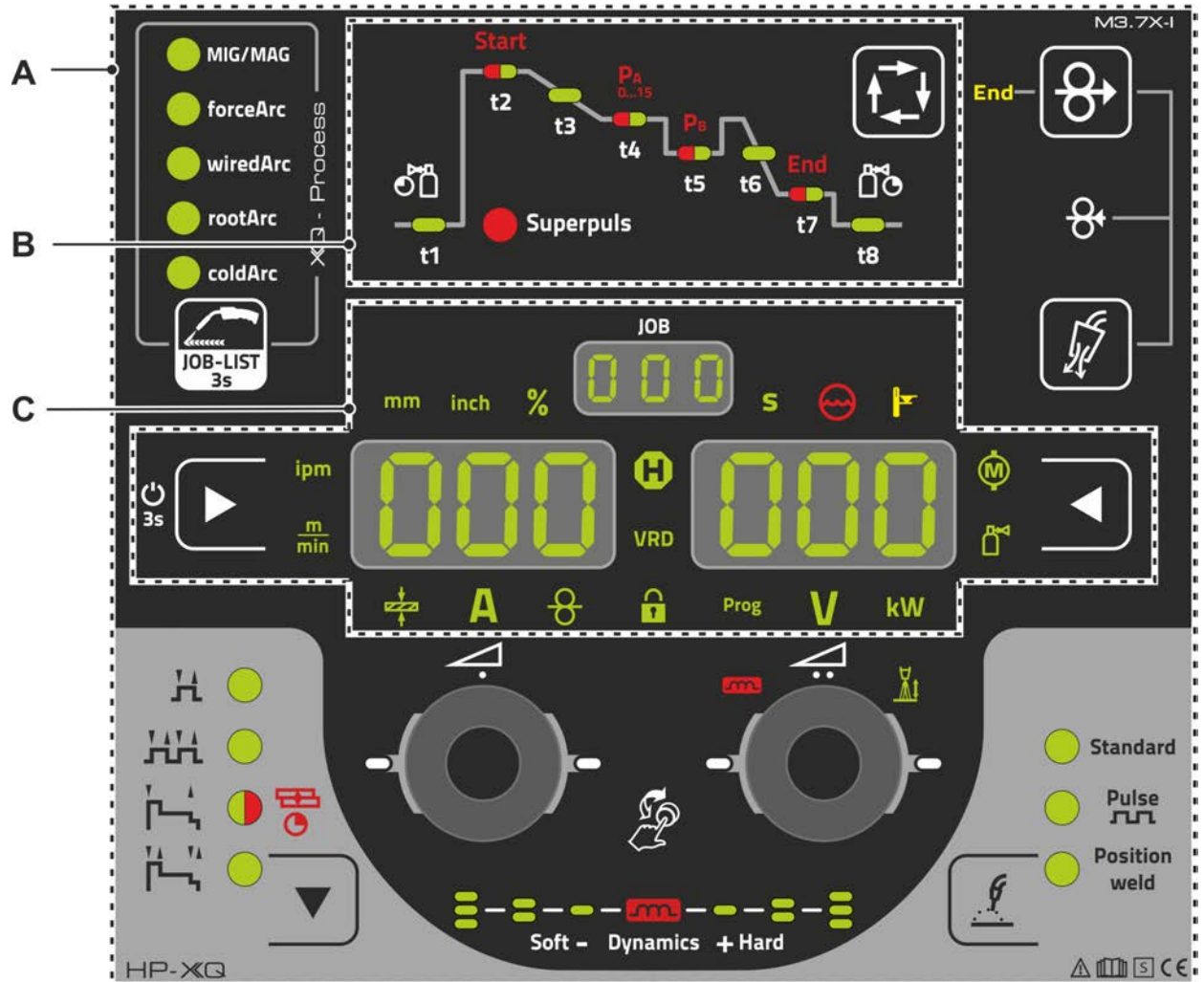

Figure 4-1

Item	Symbol	Description
1		Control section A > see 4.1.1 chapter
2		Control section B > see 4.1.2 chapter
3		Control section C > see 4.1.3 chapter



## 4.1.1 Control section A

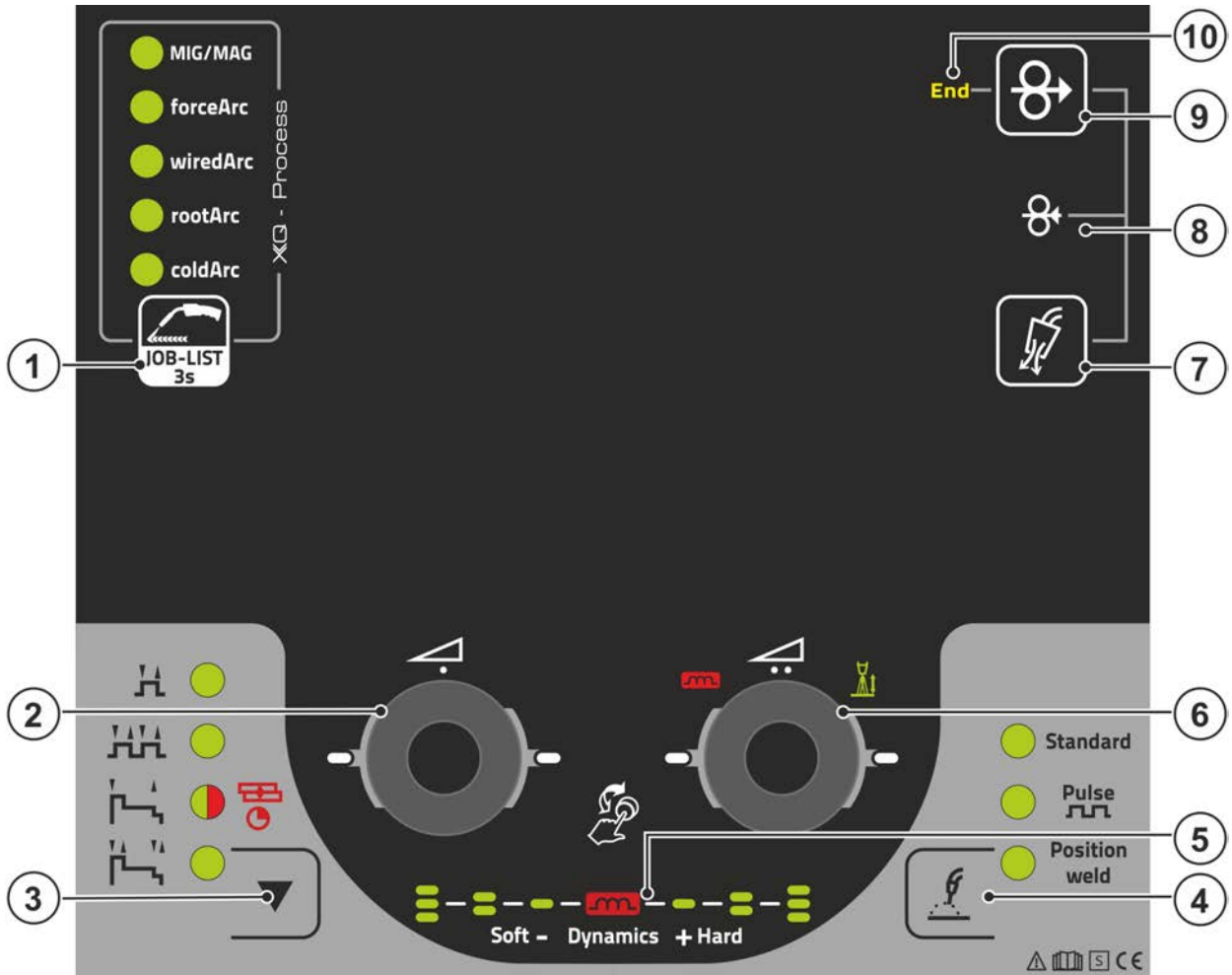

Figure 4-2

Item	Symbol	Description
1		<b>Welding task push-button (JOB)</b> <ul style="list-style-type: none"> <li>----- Pressing the pushbutton briefly: Fast switching of the available welding procedures in the selected basic parameters (material/wire/gas).</li> <li>----- Pressing the pushbutton longer: Select the welding task (JOB) from the welding task list (JOB-LIST) &gt; see 5.4.1 chapter.</li> </ul>
2		<b>Rotary knob (click wheel) for welding power</b> <ul style="list-style-type: none"> <li>----- Setting the welding power &gt; see 5.4.3 chapter</li> <li>----- Setting various parameters values depending on the preselection. (Settings can be made when the backlight is activated.)</li> </ul>
3		<b>Operating modes push-button (functional sequences) &gt; see 5.4.7 chapter</b> <ul style="list-style-type: none"> <li> ----- Non-latched</li> <li> ----- Latched</li> <li> ----- Signal light turns green: Special non-latched</li> <li> ----- Signal light turns red: MIG spots</li> <li> ----- Special latched</li> </ul>
4		<b>Welding type push-button &gt; see 5.4.2.3 chapter</b>
5		<b>Display of arc dynamics</b> The height and orientation of the set arc dynamics are displayed.



Item	Symbol	Description
6		<b>Correction of arc length with click wheel</b> <ul style="list-style-type: none"> <li>-----Setting the correction of arc length &gt; see 5.4.3.2 chapter</li> <li>-----Setting the arc dynamics &gt; see 5.4.3.3 chapter</li> <li>-----Setting various parameter values depending on the preselection.</li> </ul> Settings can be made when the backlight is activated.
7		<b>Push-button gas test / rinse hose package &gt; see 5.1 chapter</b>
8		<b>Wire return &gt; see 5.3 chapter</b> Potential and gas-free return of the wire electrode.
9		<b>Wire inching push-button</b> Potential and gas-free inching of the wire electrode > see 5.2 chapter.
10	End	<b>Signal light wire reserve sensor (ex works option) &gt; see 5.7.2 chapter</b> Lights up when the welding wire is less than approx. 10% residual quantity.

## 4.1.2 Control section B

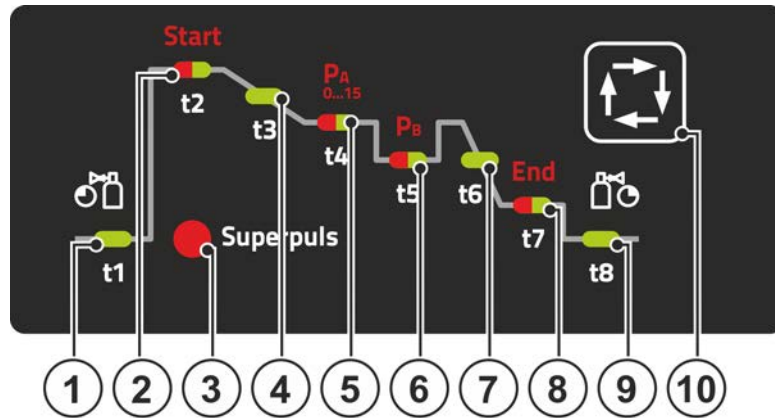

Figure 4-3

Item	Symbol	Description
1	t1	<b>Gas pre-flow time signal light</b>
2	t2	<b>Start program signal light Start</b> <ul style="list-style-type: none"> <li>-----Welding power (percent of main program P<sub>A</sub>)</li> <li>-----Arc length correction</li> <li>-----Start time "t1"</li> </ul> Start and end programs are only active in 2- and 4-cycle-special modes.
3	Superpuls	<b>Signal lamp, superPuls function</b> Lights up when the superPuls function is active.
4	t3	<b>Slope time "tS1" signal light</b> Slope time from program Start on main program P <sub>A</sub>
5	t4	<b>Main program signal light (P<sub>A</sub>)</b> <ul style="list-style-type: none"> <li>-----Welding power (wire feed speed/welding current/material thickness)</li> <li>-----Arc length correction</li> <li>-----Main program duration "t2" (Superpuls)</li> </ul>
6	t5	<b>Reduced main program signal light (P<sub>B</sub>)</b> <ul style="list-style-type: none"> <li>-----Wire feed speed (percent of main program P<sub>A</sub>)</li> <li>-----Arc length correction</li> <li>-----Down-slope program duration "t3" (Superpuls)</li> </ul>
7	t6	<b>Slope time "tSE" signal light</b> Slope time from main program Start to end program End

Item	Symbol	Description
8	t7	<b>End program signal light End</b> ----- Wire feed speed (percent of main program P <sub>A</sub> ) ----- Arc length correction ----- End current time "t10" Start and end programs are only active in the 2- and 4-cycle Special modes.
9	t8	<b>Gas post-flow time signal light</b>
10		<b>Select welding parameters button</b> This button is used to select the welding parameters depending on the welding process and operating mode used.

### 4.1.3 Control section C

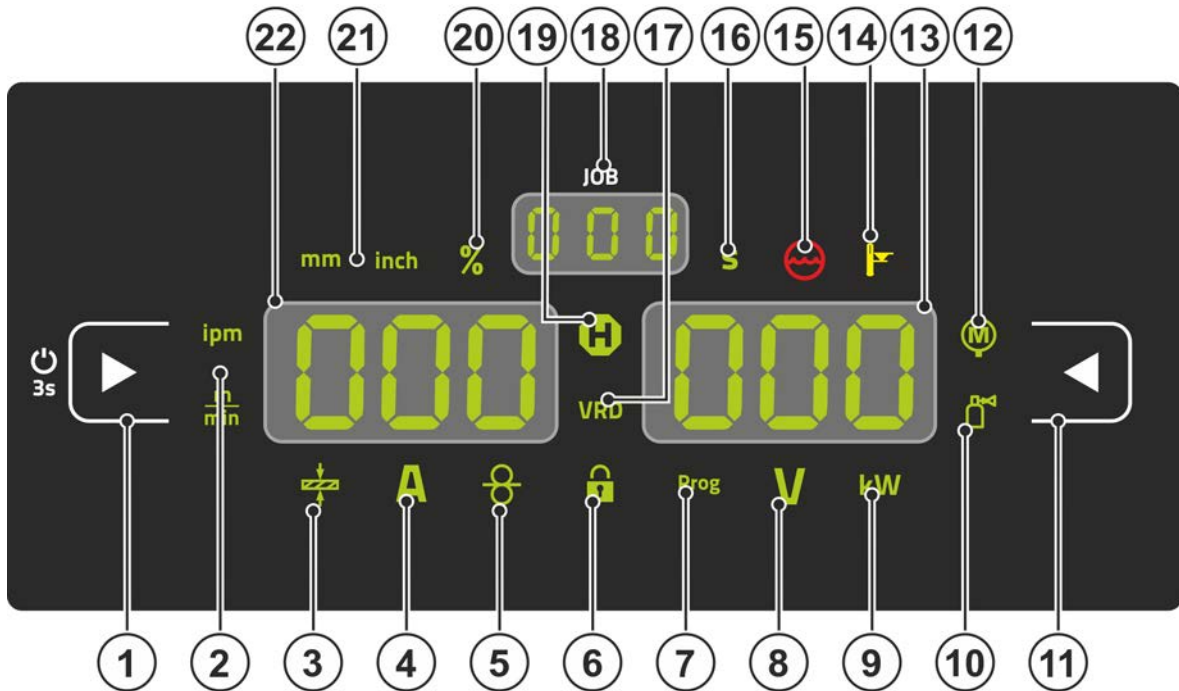















Figure 4-4

Item	Symbol	Description
1		<b>Display left / Lock function push-button</b> Switching the device display between various welding parameters. Signal lamps show the selected parameter. ----- Press for 3 s to put the machine into lock function > see 4.3.6 chapter.
2	ipm m/min	<b>Wire feed speed unit signal light</b> m/min --- Parameter value is displayed in meters per minute. ipm----- Parameter value is displayed in inches per minute. Switching between metric or imperial system via special parameters "P29" > see 5.10 chapter.
3		<b>Material thickness signal light</b> Indication of the selected material thickness.
4	<b>A</b>	<b>Welding current signal light</b> Display of the welding current in amperes.
5		<b>Signal light, Wire speed</b> Lights when the wire speed is shown on the display.
6		<b>Lock function signal light</b> Use display left / lock function push-button to switch on and off.
7	<b>Prog</b>	<b>Signal light for the welding program &gt; see 5.4.5 chapter</b> Display of the current program number in the welding data display.

Item	Symbol	Description
8		<b>Correction voltage arc length signal light</b> Display of correction voltage arc length in volts.
9		<b>Welding power signal light</b> Display of welding power in kilowatts.
10		<b>Electronic gas flow control signal light OW DGC &gt; see 5.7.1 chapter</b> Shows the gas flow rate in the device display.
11		<b>Display push-button, right</b> Primary display of arc length correction and other parameters and their values.
12		<b>Motor current signal light</b> During wire inching, the current motor current (wire feed mechanism) is displayed in amperes.
13		<b>Display right - Primary display of welding voltage</b> This display shows the welding voltage, arc length correction, programs or welding power (switching by Display right push-button). Furthermore, dynamics and, depending on the preselection, various welding parameter values are displayed. Parameter times or hold values > see 4.2 chapter.
14		<b>Excess temperature signal light / Welding torch cooling failure</b> For error messages > see 7 chapter
15		<b>Coolant fault signal light</b> Indicates flow fault or low coolant level.
16		<b>Second signal light</b> The displayed value is displayed in seconds.
17		<b>Voltage reduction device (VRD) signal light &gt; see 5.9 chapter</b>
18		<b>JOB number display (welding task) &gt; see 5.4.1 chapter</b>
19		<b>Status display signal light (Hold)</b> Display of average values across the entire welding process.
20		<b>Percent signal light</b> The displayed value is displayed in percent.
21	mm inch	<b>Material thickness unit signal light</b> mm -----Parameter value is displayed in millimeters. inch -----Parameter value is displayed in inches. Switching between metric or imperial system via special parameters "P29" > see 5.10 chapter.
22		<b>Display left - Primary display of welding power</b> This display shows the welding power either as wire feed speed, welding current or material thickness (switching by display push-button on the left). Furthermore, depending on the preselection, various welding parameter values are displayed. Parameter times or hold values > see 4.2 chapter.

## 4.2 Welding data display

On the left and right of the parameter displays there are push-buttons for the selection of parameters. They are used to select the welding parameters to be displayed and their values.

Each time one the button is clicked, the display proceeds to the next parameter (signal lights indicate the selection). After reaching the last parameter, the system is restarted with the first one.

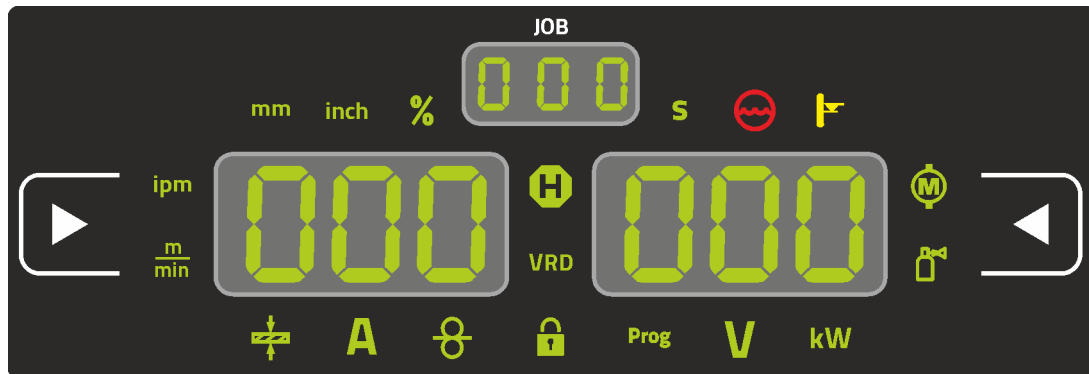

Figure 4-5

### MIG/MAG

Parameter	Nominal values <sup>[1]</sup>	Actual values <sup>[2]</sup>	Hold values <sup>[3]</sup>
Welding current	✓	✓	✓
Material thickness	✓	✗	✗
Wire feed speed	✓	✓	✓
Welding voltage	✓	✓	✓
Welding power	✗	✓	✓
Motor current	✗	✓	✗
Shielding gas	✓	✓	✗

### TIG

Parameter	Nominal values <sup>[1]</sup>	Actual values <sup>[2]</sup>	Hold values <sup>[3]</sup>
Welding current	✓	✓	✓
Welding voltage	✓	✓	✓
Welding power	✗	✓	✓
Shielding gas	✓	✓	✗

### MMA

Parameter	Nominal values <sup>[1]</sup>	Actual values <sup>[2]</sup>	Hold values <sup>[3]</sup>
Welding current	✓	✓	✗
Welding voltage	✓	✓	✗
Welding power	✗	✓	✗

When settings are changed (e.g. wire feed speed) the display immediately switches to nominal value setting.

<sup>[1]</sup> Nominal values (before welding)

<sup>[2]</sup> Actual values (during welding)

<sup>[3]</sup> Hold values (after welding, display of average values across entire welding process)

## 4.3 Operating the machine control

### 4.3.1 Main screen

The machine control switches to the main screen after it has been turned on or a setting has been completed. This means that the previously selected settings (indicated by signal lights where applicable) and the nominal value for the current (A) are displayed in the left-hand welding data display. Depending on the selection, the right-hand display shows the welding voltage (V) nominal value or the welding power (kW) actual value. The control always switches back to the main screen after 4 sec..

### 4.3.2 Welding power setting

The welding power is adjusted with the rotary knob (click wheel) for welding power. You can also adjust the parameters in the operation sequence or settings in the various machine menus.

#### MIG/MAG settings

The welding power (heat input into the material) can be changed by setting the following three parameters:

- wire feed speed ⌘
- material thickness ⚡
- welding current A

These three parameters are interdependent and always change together. The significant parameter is the wire feed speed in m/min. The wire feed speed can be adjusted in increments of 0.1 m/min (4.0 ipm). The associated welding current and material thickness are determined from the wire feed speed.

The welding current displayed and material thickness are to be understood as guide values for the user and rounded to full amperage and 0.1 mm material thickness.

A change in the wire feed speed, for example by 0.1 m/min, leads to a more or less large change in the welding current displayed or in the material thickness displayed depending on the selected welding wire diameter. The display of the welding current and the material thickness are also dependent on the selected wire diameter.

For example, a change in wire feed speed of 0.1 m/min and a selected wire diameter of 0.8 mm results in a smaller change in the current or thickness of material than a change in wire feed speed of 0.1 m/min and a selected wire diameter of 1.6 mm.

Depending on the diameter of the wire to be welded, it is possible that smaller or larger jumps in the display of material thickness or welding current take place or changes of these values become visible only after several “clicks” on the rotary transducer. As described above, the reason for this is the change in the wire feed speed by 0.1 m/min per click and the resulting change in the current or material thickness as a function of the preselected welding wire diameter.

Please note also that the guide value of the welding current displayed before welding may deviate from the guide value during welding depending on the actual stick-out (free wire end used for welding).

The reason lies in the preheating of the free wire end by the welding current. For example, the preheating in the welding wire increases with the length of the stick-out. This means if the stick-out (free wire end) increases, the actual welding current decreases due to larger preheating in the wire. If the free wire end decreases, the actual welding current increases. This enables the welder to influence the heat input in the component within limits by changing the distance of the welding torch.

#### Setting of TIG/MMA:

The welding power is set with the parameter “welding current” that can be adjusted in increments of 1 ampere.

### 4.3.3 Welding parameter setting in the operation sequence

A welding parameter can be set in two ways in the operation sequence.

1. Pressing the welding parameter push-button (a flashing signal light indicates the selected parameter). The parameter setting is carried out by the welding power click wheel.
2. Press briefly on the welding power click wheel (operation sequence selection) and then turn the button (navigate to the required parameter). Press again to apply the selected parameter as the setting (corresponding parameter value and signal light flash). Turn the button to set the parameter value.

## 4.3.4 Setting advanced welding parameters (Expert menu)

The Expert menu contains functions and parameters which cannot be set directly in the machine control or which do not need to be set on a regular basis. The number and display of these parameters depends on the previously selected welding procedure or the functions. To select them hold the welding power click wheel (> 2 s). Select the required parameter/menu item by turning (navigating) and pressing the click wheel. Additionally or alternatively, you can use the welding parameters push-button for navigation.

## 4.3.5 Changing basic settings (machine configuration menu)

The basic welding system functions can be adjusted in the machine configuration menu. Only experienced users should change the settings > see 5.11 chapter.

## 4.3.6 Lock function

The lock function protects against accidental adjustment of the device settings.

The user can switch the lock function on or off by pressing the button for a long time from each machine control or accessory component with the symbol .

### 5 Functional characteristics

#### 5.1 Shielding gas volume settings

If the shielding gas setting is too low or too high, this can introduce air to the weld pool and may cause pores to form. Adjust the shielding gas quantity to suit the welding task!

- Slowly open the gas cylinder valve.
- Open the pressure regulator.
- Switch on the power source at the main switch.
- Trigger gas test > see 5.1.1 chapter function (welding voltage and wire feed motor remain switched off – no accidental arc ignition).
- Set the relevant gas quantity for the application on the pressure regulator.

#### Setting instructions

Welding process	Recommended shielding gas quantity
MAG welding	Wire diameter x 11.5 = l/min
MIG brazing	Wire diameter x 11.5 = l/min
MIG welding (aluminium)	Wire diameter x 13.5 = l/min (100 % argon)
TIG	Gas nozzle diameter in mm corresponds to l/min gas throughput

#### Helium-rich gas mixtures require a higher gas volume!

The table below can be used to correct the gas volume calculated where necessary:

Shielding gas	Factor
75% Ar/25% He	1.14
50% Ar/50% He	1.35
25% Ar/75% He	1.75
100% He	3.16

#### 5.1.1 Gas test

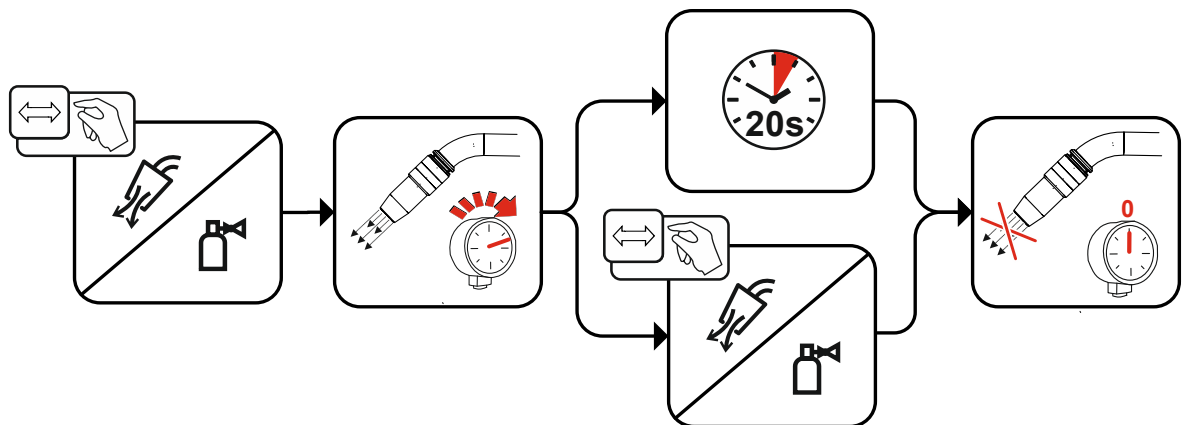

Figure 5-1

## 5.1.2 Purge hose package

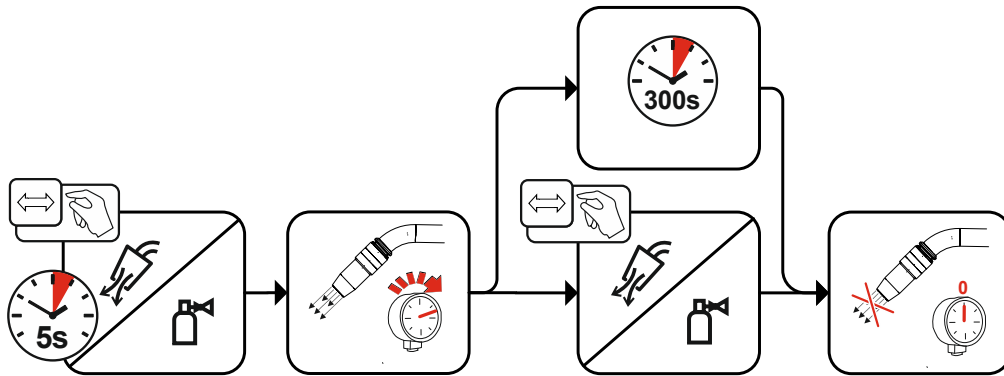

Figure 5-2

## 5.2 Wire inching

The wire inching function is used for potential- and gas-free inching of the wire electrode after the wire spool change. By pressing and holding the wire inching button for a long time, the wire inching speed increases in a ramp function (special parameter P1 > see 5.10.3.1 chapter) from 1 m/min to the set maximum value. The maximum value is set by simultaneously pressing the wire inching button and turning the left click wheel.

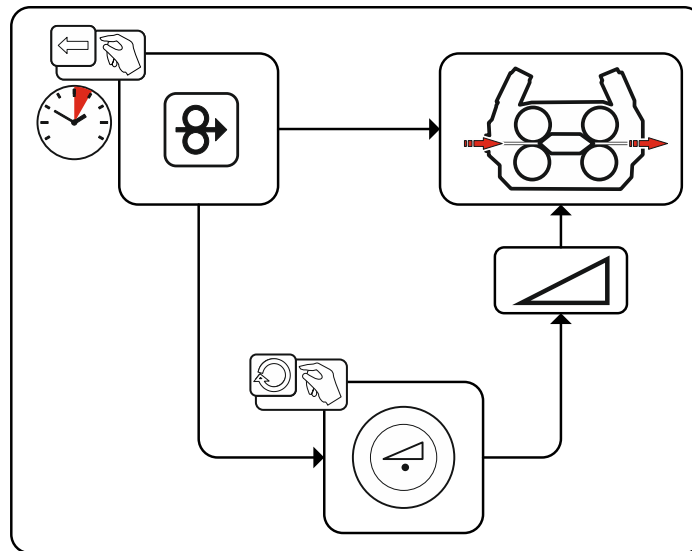

Figure 5-3



### 5.3 Wire return

The wire return function is used to retract the wire electrode without tension and protection gas. By simultaneously pressing and holding the wire inching and gas test buttons, the wire return speed increases in a ramp function (special parameter P1 > see 5.10.3.1 chapter) from 1 m/min to the set maximum value. The maximum value is set by simultaneously pressing the wire inching button and turning the left click wheel.

During the process, the wire spool must be turned by hand clockwise to wind up the wire electrode again.

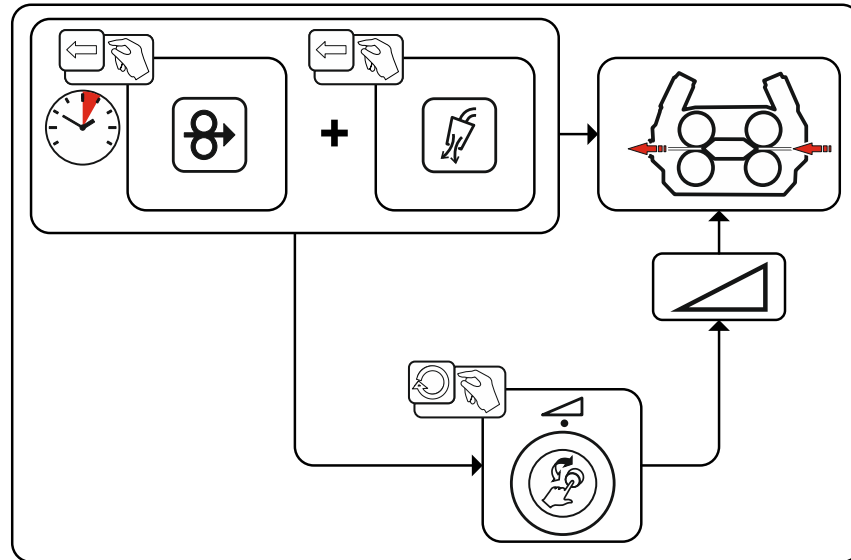

Figure 5-4

## 5.4 MIG/MAG welding

### 5.4.1 Welding task selection

The following steps have to be carried out to select the welding job:

- Select basic parameters (material type, wire diameter and shielding gas type) and welding procedures (select and enter JOB number by means of JOB-List > see 8.1 chapter).
- Select operating and welding type
- Adjust welding power
- Correct arc length and dynamics if necessary
- Adjust expert parameters for special applications

### 5.4.2 Basic welding parameters

The user must first determine the basic parameters (material type, wire diameter and shielding gas type) of the welding system. These basic parameters are then compared with the welding job list (JOB-LIST). The combination of the basic parameters gives a JOB number, which must now be entered on the control unit. This basic setting must be rechecked or adjusted only when changing the wire or gas.

The range of functions depends on the machine series:

Machine series	MIG/MAG XQ	forceArc XQ	wiredArc XQ	rootArc XQ	coldArc XQ
Titan XQ	✓	✓	✓	✓	✓
Phoenix XQ	✓	✓	✗	✓	✗
Taurus XQ	✓	✓	✗	✓	✗

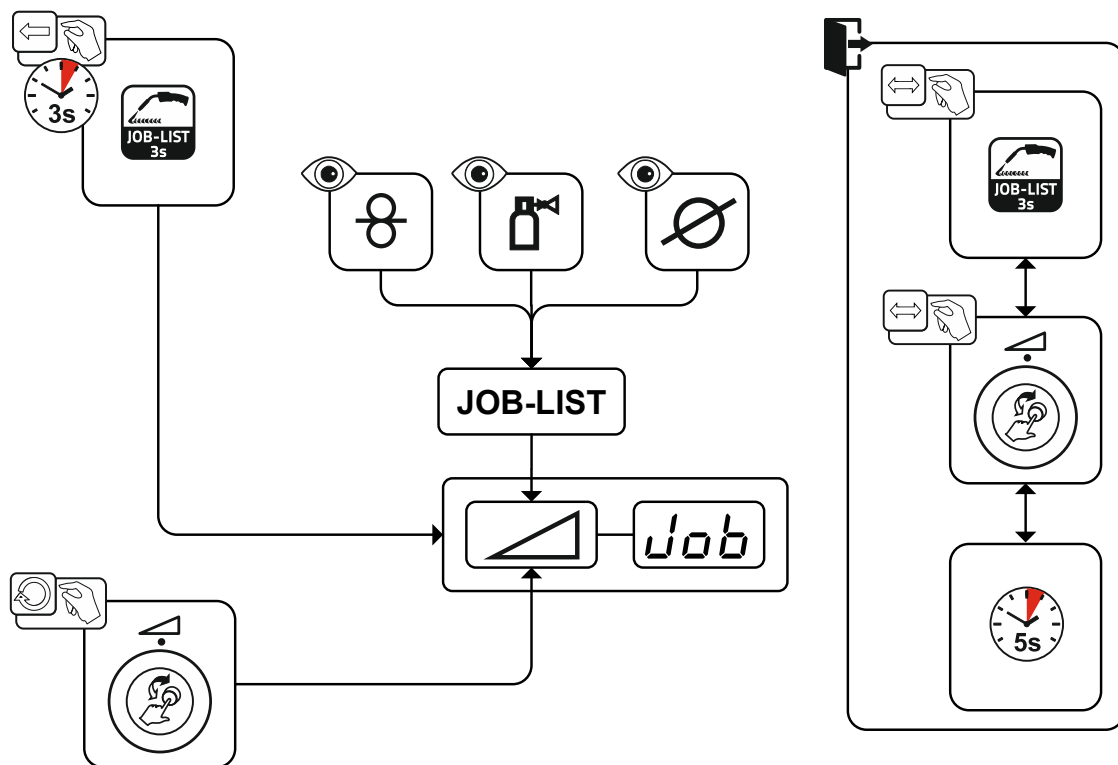

Figure 5-5

## 5.4.2.1 Welding procedure

After setting the basic parameters you can switch between the welding procedures MIG/MAG, forceArc, wiredArc, rootArc und coldArc (if there is a corresponding combination of the basic parameters). The process change will also change the JOB number, but the basic parameters remain unchanged.

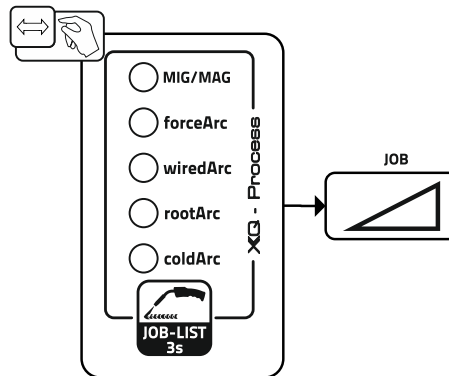

Figure 5-6

## 5.4.2.2 Operating mode

The operating mode determines the process sequence controlled by the welding torch. Detailed descriptions of the operating modes > see 5.4.7 chapter.

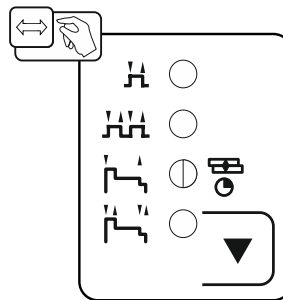

Figure 5-7

### 5.4.2.3 Welding type

Different forms of MIG/MAG processes are referred to as welding type.

#### Standard (Welding with standard arc)

Depending on the set combination of wire feed speed and arc voltage, the arc types short arc, transitional arc or spray arc can be used for welding.

#### Pulse (Welding with pulsed arc)

A targeted change in the welding current generates current pulses in the arc, which lead to a 1 drop per pulse of material transfer. The result is an almost spatter-free process, suitable for welding of all materials, in particular high-alloy CrNi steels or aluminium.

#### Positionweld (Positional welding)

A combination of the pulse/standard or pulse/pulse welding types, which is particularly suitable for positional welding due to factory-optimized parameters.

The range of functions depends on the machine series:

Machine series	Standard	Pulse	Positionweld
Titan XQ	✔	✔	✔
Phoenix XQ	✔	✔	✔ [1]
Taurus XQ	✔	✘	✘

[1] Aluminium welding

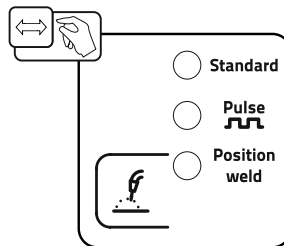

Figure 5-8

### 5.4.3 Welding power (operating point)

The welding power is adjusted according to the principle of one-knob operation. The user can set their operating point optionally as wire feed speed, welding current or material thickness. The optimum welding voltage for the operating point is calculated and set by the welding machine. If necessary, the user can correct this welding voltage > see 5.4.3.2 chapter.

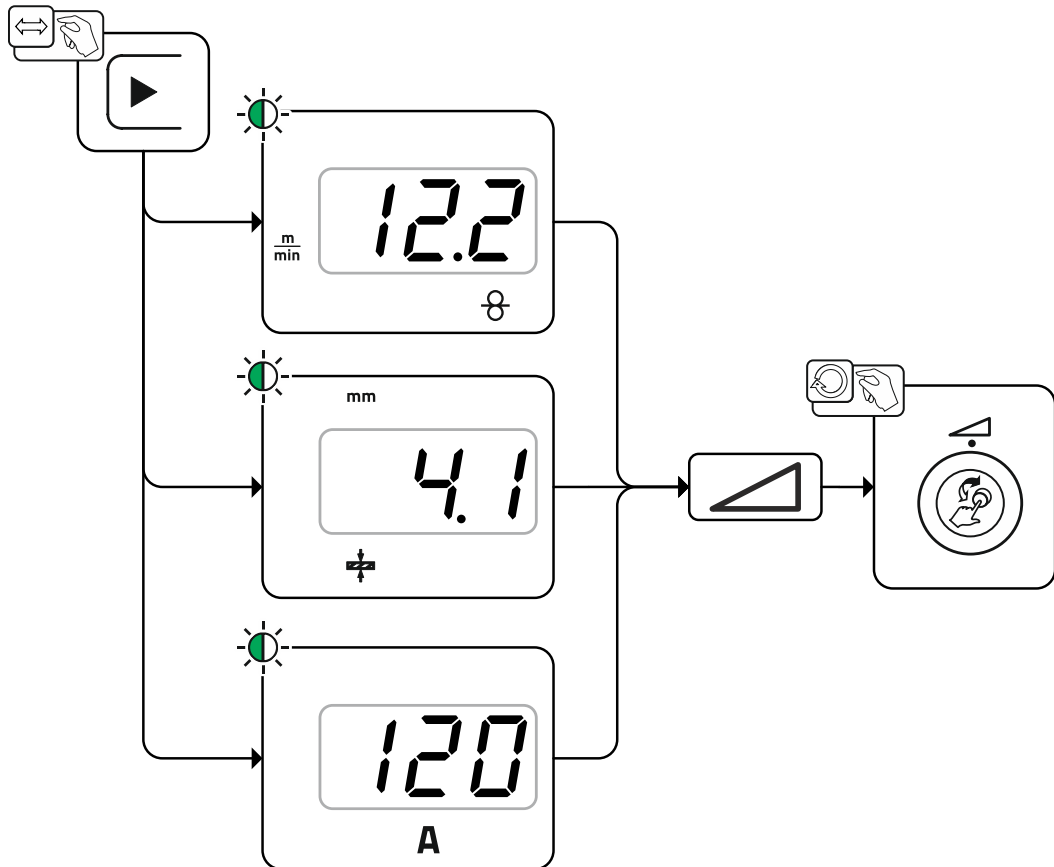

Figure 5-9

#### Application example (setting via material thickness)

The required wire feed speed is not known and is to be determined.

- Select welding task JOB 76( > see 5.4.1 chapter): material = AlMg, gas = Ar 100%, wire diameter = 1.2 mm.
- Switch the display to material thickness.
- Measure the material thickness (workpiece).
- Set the measured value, e.g. 5 mm, at the machine control.  
This set value corresponds to a specific wire feed speed. Switching the display to this parameter will show the associated value.

**In this example, a material thickness of 5 mm corresponds to a wire feed speed of 8.4 m/min.**

The material thickness details in the welding programs generally refer to fillet welds in the PB welding position. They should be regarded as guideline values and may differ in other welding positions.

#### 5.4.3.1 Accessory components for operating point setting

The operating point can be set at various accessory components as well, such as remote control, special welding torches or robot and industrial bus interfaces (optional interface for automated welding required, not available for all machines of this series).

See the operating instructions for the machine in question for a more detailed description of the individual machines and their functions.

## 5.4.3.2 Arc length

When required, the arc length (welding voltage) can be adjusted for the welding task in hand by  $\pm 9.9$  V.

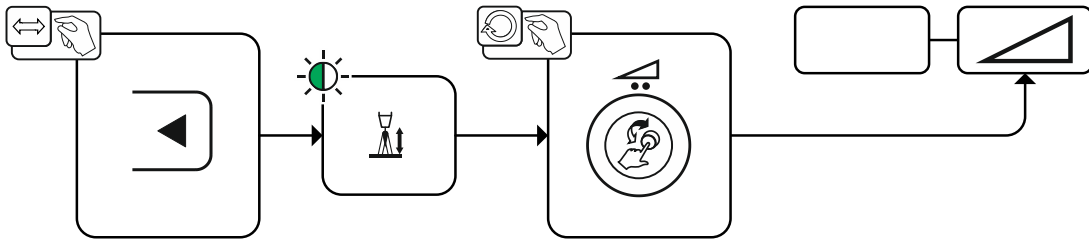

Figure 5-10

## 5.4.3.3 Arc dynamics (choke effect)

This function can be used to adjust the arc between a narrow, hard arc with deep penetration (positive values) and a wide and soft arc (negative values). In addition, the selected settings are displayed with signal lights below the rotary knobs.

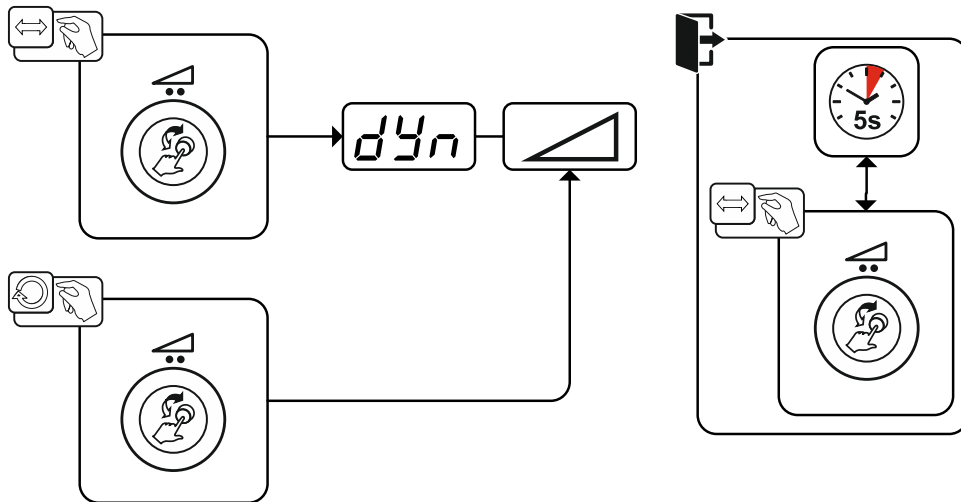

Figure 5-11

### 5.4.3.4 superPuls

In superPuls mode, the program toggles between the main program (PA) and the reduced main program (PB). This function is e.g. used for thin sheet welding to reduce the heat input in a controlled manner or for positional welding without the need for weaving.

The welding power can be represented as average value (ex works) or solely as program A value. If the average value display is activated the signal lights of the main (PA) and reduced main program (PB) are illuminated simultaneously. The display variants can be toggled using special parameter P19, > see 5.10 chapter.

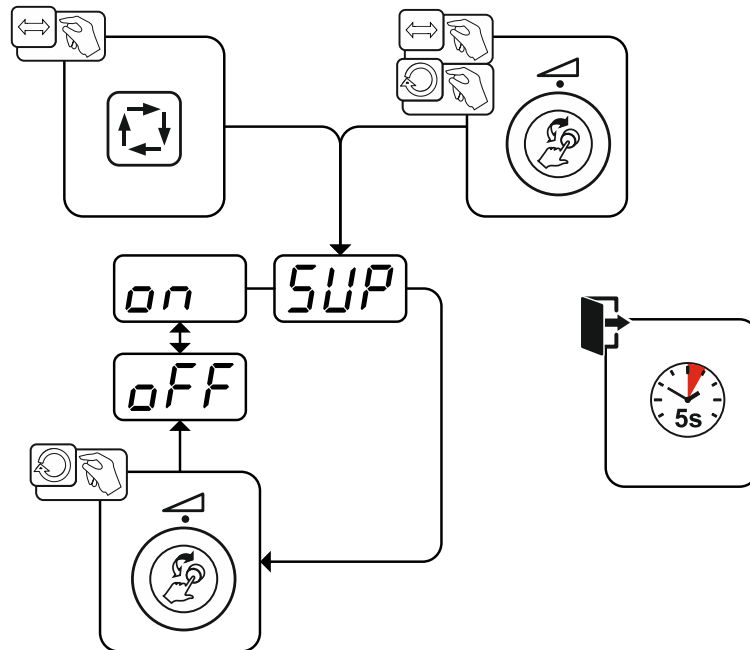

Figure 5-12

Display	Setting/selection
<b>SUP</b>	<b>Selects superPuls</b> Switches function on or off.
<b>on</b>	<b>Switch on</b> Switching on machine function
<b>off</b>	<b>Switch off</b> Switching off machine function

## 5.4.3.5 Copy JOB (welding task)

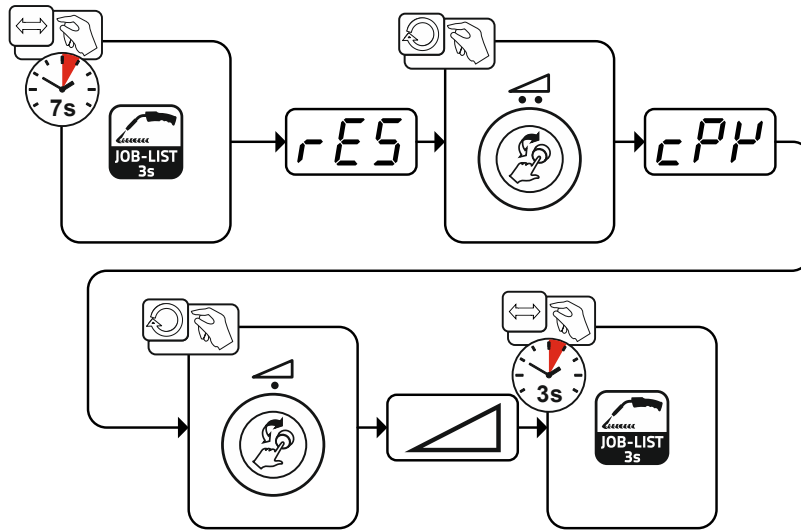

Figure 5-13



## 5.4.4 Expert menu (MIG/MAG)

The Expert menu has adjustable parameters stored that don't require regular setting. The number of parameters shown may be limited, e.g. if a function is deactivated.

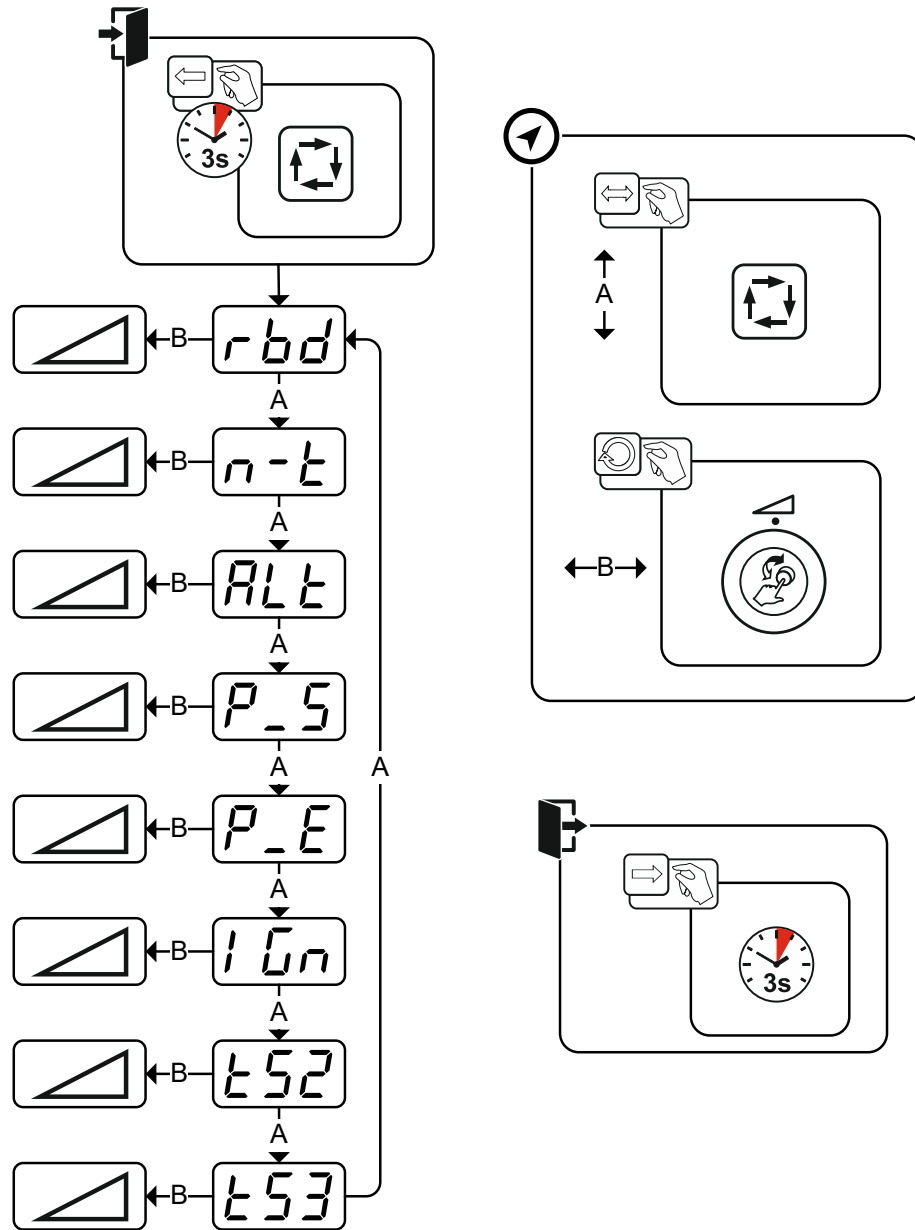
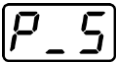

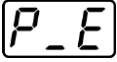

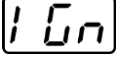
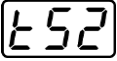
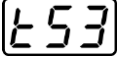

Figure 5-14

Display	Setting/selection
	<b>Burn-back time &gt; see 5.4.4.1 chapter</b> • ----- Increase value > increase wire burn-back • ----- Decrease value > decrease wire burn-back
	<b>Setting JOB-dependent program limit/n-cycle &gt; see 5.4.4.2 chapter</b> 1----- No JOB-dependent program limit 2-9 ----- JOB-dependent program limit for max. selectable programs.
	<b>Change welding process (process switching)</b> With this function activated the welding process switches from standard arc welding to pulse arc welding. Switching is effected by either tapping the torch trigger (special latched) or by activating the superPuls function (switch between program P <sub>A</sub> and P <sub>B</sub> ). <input type="checkbox"/> <b>on</b> ----- Function activated. <input type="checkbox"/> <b>oFF</b> ----- Function deactivated.

Display	Setting/selection
	<b>Pulse arc welding process (program P<sub>START</sub>)</b> The pulse arc welding process can be activated in the start program (P <sub>START</sub> ) with the special non-latched and special latched operating modes.  ----- Function activated.  ----- Function deactivated.
	<b>Pulse arc welding process (program P<sub>END</sub>)</b> The pulse arc welding process can be activated in the end program (P <sub>END</sub> ) with the special non-latched and special latched operating modes.  ----- Function activated.  ----- Function deactivated.
	<b>Ignition type (MIG/MAG)</b> Application: Low-spatter ignition, e.g. for aluminium and chrome/nickel materials. 0 = ----- Traditional arc ignition 1 = ----- Arc ignition with wire return for push/pull applications 2 = ----- Arc ignition with wire return for non-push/pull applications
	<b>Slope time (main current to secondary current)</b>
	<b>Slope time (main current to secondary current)</b>

#### 5.4.4.1 Burn-back

The wire burn-back parameter prevents the sticking of the wire electrode in the weld pool or at the contact tip at the end of the welding process. The value is optimally preset for a variety of applications (but can be adjusted if necessary). The adjustable value stands for the time until the power source switches off the welding current after the welding process has been stopped.

Welding wire behaviour	Setting instructions
Wire electrode is sticking in the weld pool.	Increase value
Wire electrode is sticking on the contact tip or large ball formation on the wire electrode	Reduce value

#### 5.4.4.2 Programme limit

The JOB-dependent program limit allows you to limit the number of programs that can be selected in the selected JOB to (2...9). This option can be set individually per JOB. In addition, a legacy option to set a "global program limit" is also available. To set this option use special parameter P4. This setting is then applied to all JOBS for which no JOB-dependent program limit has been set (see the special parameters description).

You can also use the "Special latched (n-cycle)" operating mode if special parameter 8 is set to 2. In this case (JOB-dependent program switching activated, special parameter 8 = 2, special latched) you can switch to the next program by tapping the torch trigger in the main program (see the special parameters description).

#### 5.4.5 Programs (P<sub>A</sub> 1-15)

In the manual program P0, the user can adjust the operating point in a conventional way using the parameter settings on the machine control. The active program is shown in the main menu of the machine display in the display area for process parameters with the letter "P" and the corresponding program number.

Different welding tasks or positions on a workpiece require different welding power values (operating points) or parameter settings. These settings can be stored in up to 15 programs (P1 to P15) and recalled, as needed, at the machine control or a suitable accessory component (e.g. welding torch).

Welding parameters for program 0 (P0) are changed for decompact machine systems at the machine control of the wire feeder (factory setting). To change the parameters using the Expert 2.0 machine control, the parameter "P0 changeable by Expert 2.0" must be set to "Yes".

Welding parameters for programs 1 - 15 can be changed on any control connected in the system.

The following parameters and their values are stored in each program:

- Wire feed speed and voltage correction (welding power)
- Operating mode, welding type, dynamics and setting superPuls

Changes to the parameter settings are stored in the selected program without further prompt.

## 5.4.5.1 Selection and adjustment

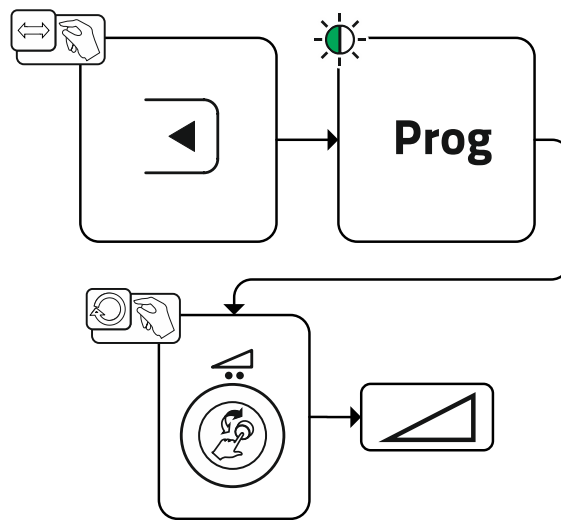

Figure 5-15

The user can change the welding parameters of the main programs with the following components.

	Program switching	JOB switching	Process switching	Welding type	Program	Operating mode	Wire feed speed	Voltage correction	Dynamics
<b>M3.7 – I/J</b> Wire feeder control			✓		P0		✓		
					P1-15				
<b>PC 300.NET</b> Software		✗	✓		P0	✓		✗	
					P1-15		✓		
<b>MT Up/Down</b> Welding torch	✓		✗		P0	✗	✓ [1]		✗
					P1-9		✗		
<b>MT 2 Up/Down</b> Welding torch	✓		✗		P0	✗	✓ [1]		✗
					P1-15		✗		
<b>MT PC 1</b> Welding torch	✓		✗		P0	✗	✓ [1]		✗
					P1-15		✗		
<b>MT PC 2</b> Welding torch	✓		✗		P0	✗	✓ [1]		✗
					P1-15		✗		
<b>PM 2 Up/Down</b> Welding torch	✓		✗		P0	✗	✓ [1]		✗
					P1-15		✗		
<b>PM RD 2</b> Welding torch	✓		✗		P0	✗	✓ [1]		✗
					P1-15		✗		
<b>PM RD 3</b> Welding torch	✓	✗	✓		P0		✓		
					P1-15				

[1] Does not apply in conjunction with wire feeders of the Drive XQ IC 200 series. These machines can only switch the wire feed speed and voltage correction in stored programs.

Example 1: Welding workpieces with different sheet metal thicknesses (non-latched)

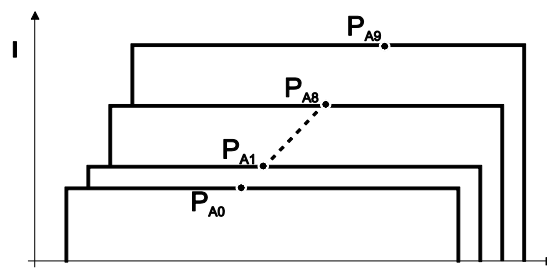

Figure 5-16

## Example 2: Welding different positions on a workpiece (latched)

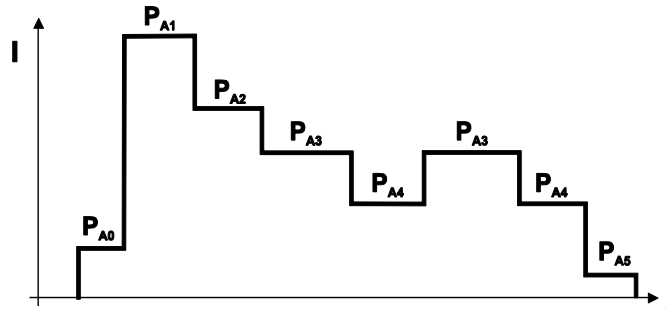

Figure 5-17

## Example 3: Aluminium welding of different sheet metal thicknesses (non-latched or latched special)

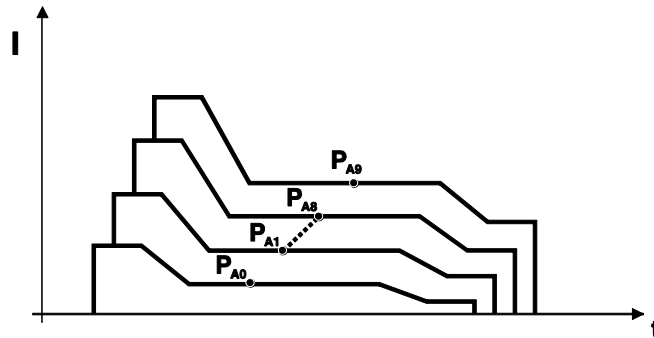

Figure 5-18

Up to 16 programs ( $P_{A0}$  to  $P_{A15}$ ) can be defined.

An operating point (wire speed, arc length correction, dynamics/choke effect) can be defined permanently in each program.

Program  $P_0$  is an exception: the settings for operating points are made manually here.

Changes to the welding parameters are saved immediately!

### 5.4.6 Program sequence

Certain materials, aluminium for example, require special functions for reliable and high-quality welding. In this case, the special latched mode is used with the following programs:

- Start program  $P_{START}$  (avoidance of cold welds at start of seam)
- Main program  $P_A$  (constant welding)
- Reduced main program  $P_B$  (targeted heat reduction)
- End program  $P_{END}$  (avoidance of end-craters by targeted heat reduction)

The programs contain parameters such as wire feed speed (operating point), correction of arc length, slope times, program duration, etc.

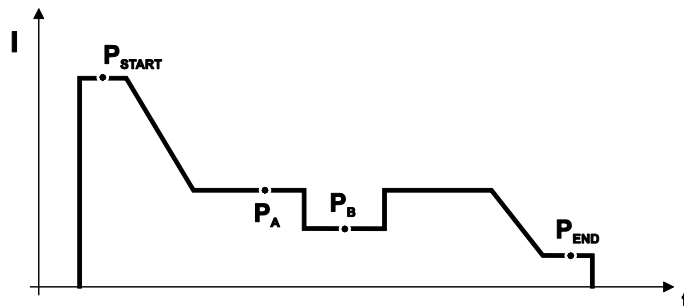

Figure 5-19

**5.4.6.1 Selection**

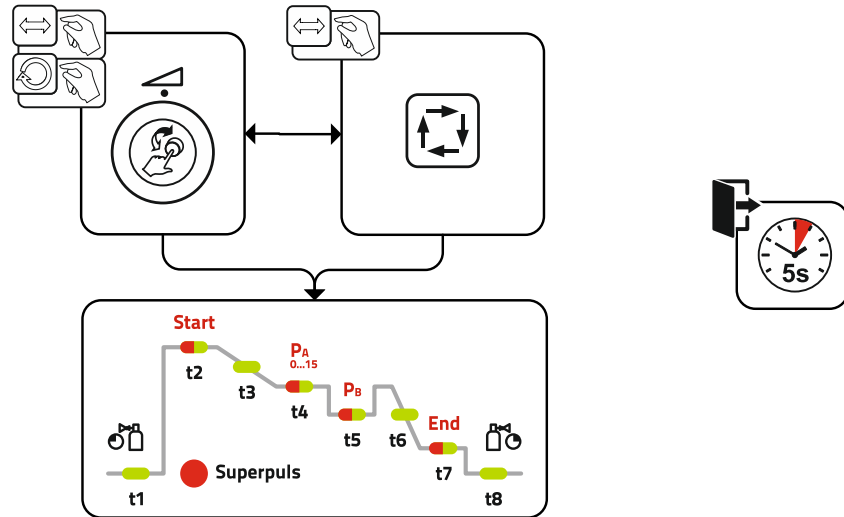

Figure 5-20

**5.4.6.2 Setting**

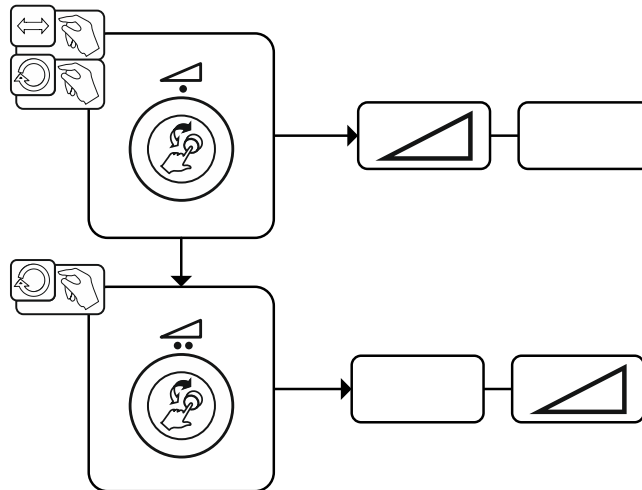

Figure 5-21

## 5.4.7 Operating modes (functional sequences)

There are optimum pre-sets for welding parameters such as gas pre-flow and burn back, etc. for numerous applications (although these can also be changed if required).

### 5.4.7.1 Explanation of signs and functions

Symbol	Meaning
	Press torch trigger
	Release torch trigger
	Tap torch trigger (press briefly and release)
	Shielding gas flowing
I	Welding output
	Wire electrode is being conveyed
	Wire creep
	Wire burn-back
	Gas pre-flows
	Gas post-flows
	Non-latched
	Special, non-latched
	Latched
	Special, latched
t	Time
P <sub>START</sub>	Ignition program
P <sub>A</sub>	Main program
P <sub>B</sub>	Reduced main program
P <sub>END</sub>	End program
t <sub>2</sub>	Spot time

### 5.4.7.2 Automatic cut-out

Once the fault periods have elapsed, the automatic cut-out stops the welding process when it has been triggered by one of two states:

- During ignition  
5 s after the start of the welding process, no welding current flows (ignition error).
- During welding  
The arc is interrupted for more than 5 s (arc interruption).



## Non-latched mode

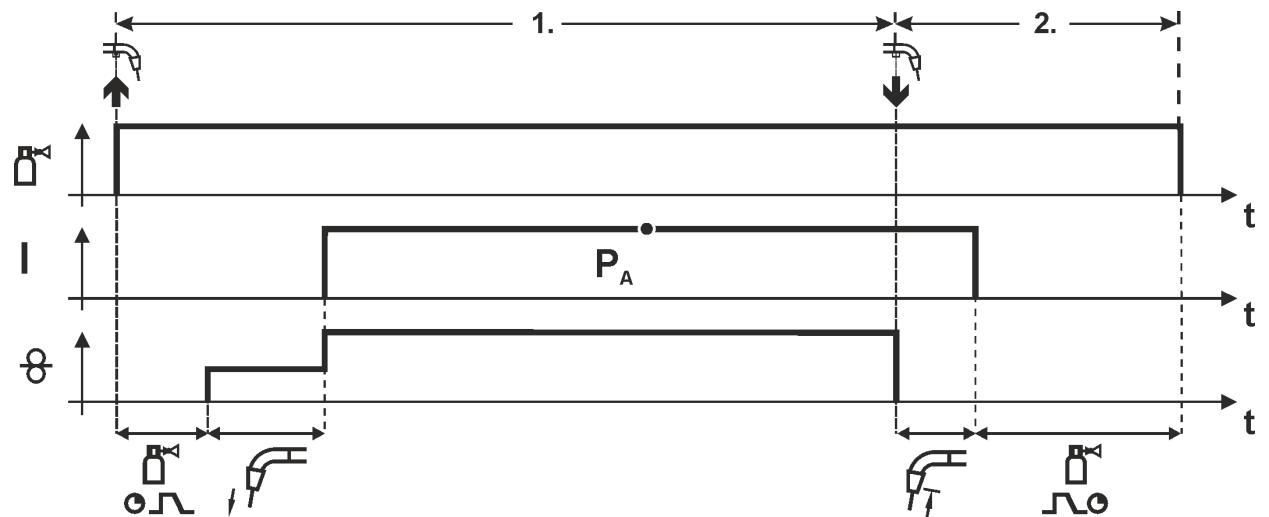

Figure 5-22

**Step 1**

- Press and hold torch trigger.
- Shielding gas is expelled (gas pre-flows).
- Wire feed motor runs at "creep speed".
- Arc ignites after the wire electrode makes contact with the workpiece; welding current flows.
- Change over to pre-selected wire speed.

**Step 2**

- Release torch trigger.
- WF motor stops.
- Arc is extinguished after the preselected wire burn-back time expires.
- Gas post-flow time elapses.

## Non-latched operation with superpulse

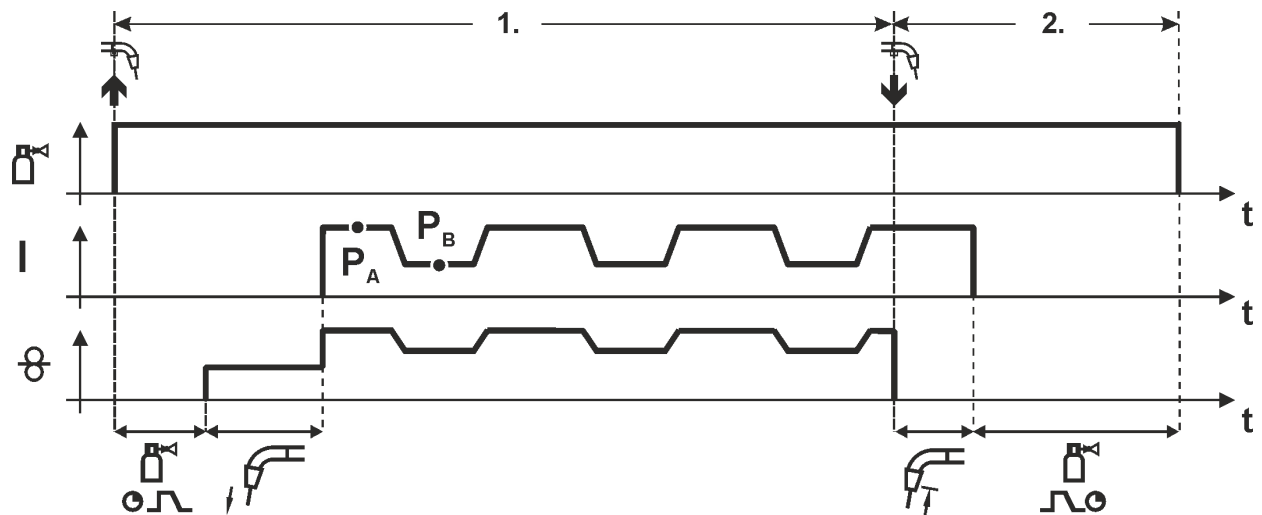

Figure 5-23

### Step 1

- Press and hold torch trigger.
- Shielding gas is expelled (gas pre-flows).
- Wire feed motor runs at “creep speed”.
- Arc ignites after the wire electrode makes contact with the workpiece; welding current flows.
- Start the super pulse function beginning with main program  $P_A$ :  
The welding parameters change at the specified times between main program  $P_A$  and the reduced main program  $P_B$ .

### Step 2

- Release torch trigger.
- Super pulse function is ended.
- WF motor stops.
- Arc is extinguished after the preselected wire burn-back time expires.
- Gas post-flow time elapses.

## Special, non-latched

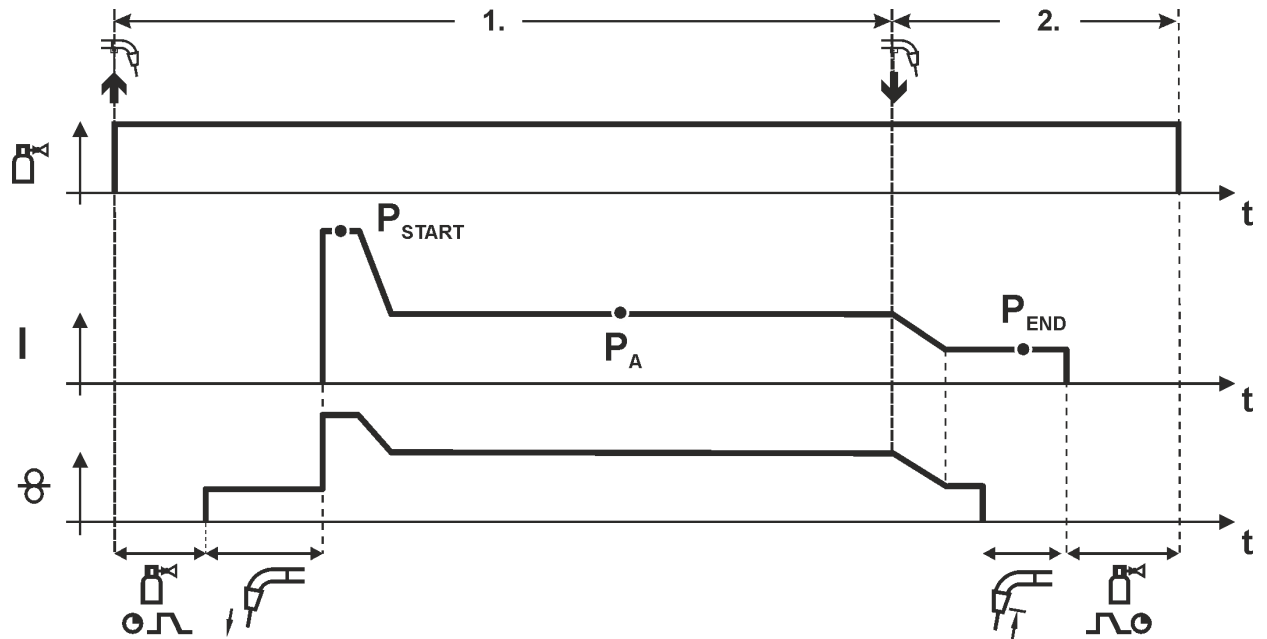

Figure 5-24

### Step 1

- Press and hold torch trigger
- Shielding gas is expelled (gas pre-flows)
- Wire feed motor runs at “creep speed”.
- Arc ignites after the wire electrode makes contact with the workpiece, welding current is flowing (start program  $P_{START}$  for the time  $t_{start}$ )
- Slope to main program  $P_A$ .

### Step 2

- Release torch trigger
- Slope to end program  $P_{END}$  for the time  $t_{end}$ .
- WF motor stops.
- Arc is extinguished after the preselected wire burn-back time expires.
- Gas post-flow time elapses.

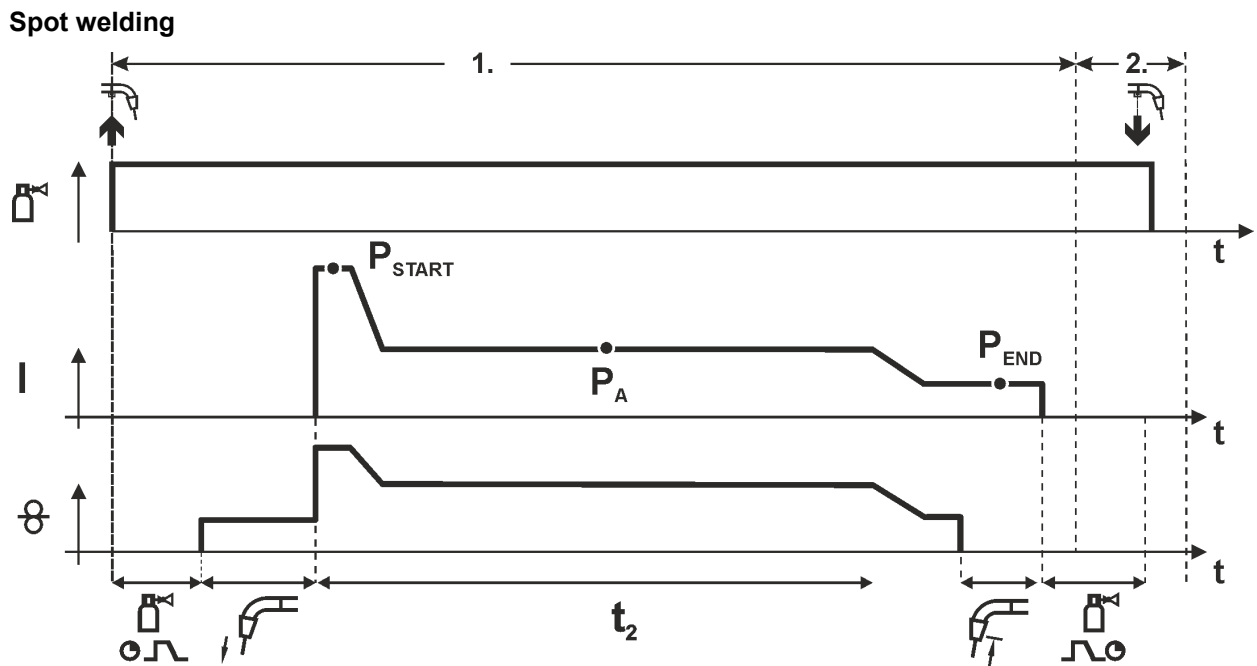

Figure 5-25

The ignition time  $t_{start}$  must be added to the spot time  $t_2$ .

### 1st cycle

- Press and hold torch trigger
- Shielding gas is expelled (gas pre-flows)
- Wire feed motor runs at "creep speed"
- Arc ignites after the wire electrode makes contact with the workpiece, welding current is flowing (start program  $P_{START}$ , spot time starts)
- Slope to main program  $P_A$
- After the set spot time elapses, slope goes to end program  $P_{END}$ .
- Wire feed motor stop welding.
- Arc is extinguished after the pre-selected wire burn-back time elapses
- Gas post-flow time elapses.

### 2nd cycle

- Release torch trigger

Releasing the torch trigger (step 2) interrupts the welding process even if the spot time has not yet elapsed (slope to end program  $P_{END}$ ).

## Special, non-latched with superpulse

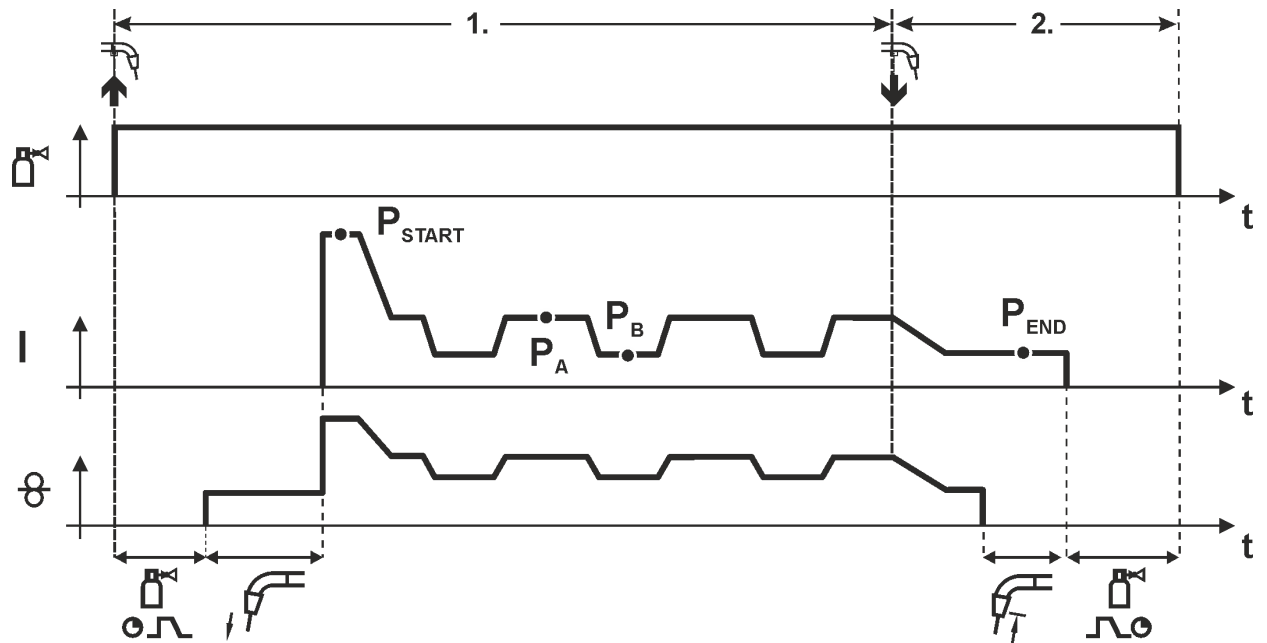

Figure 5-26

### Step 1

- Press and hold torch trigger
- Shielding gas is expelled (gas pre-flows)
- Wire feed motor runs at “creep speed”.
- Arc ignites after the wire electrode makes contact with the workpiece, welding current is flowing (start program  $P_{START}$  for the time  $t_{start}$ ).
- Slope on main program  $P_A$ .
- Start the super pulse function beginning with main program  $P_A$ :  
The welding parameters change at the specified times between main program  $P_A$  and the reduced main program  $P_B$ .

### Step 2

- Release torch trigger
- Super pulse function is ended.
- Slope to end program  $P_{END}$  for the time  $t_{end}$ .
- WF motor stops.
- Arc is extinguished after the preselected wire burn-back time expires.
- Gas post-flow time elapses.

## Latched mode

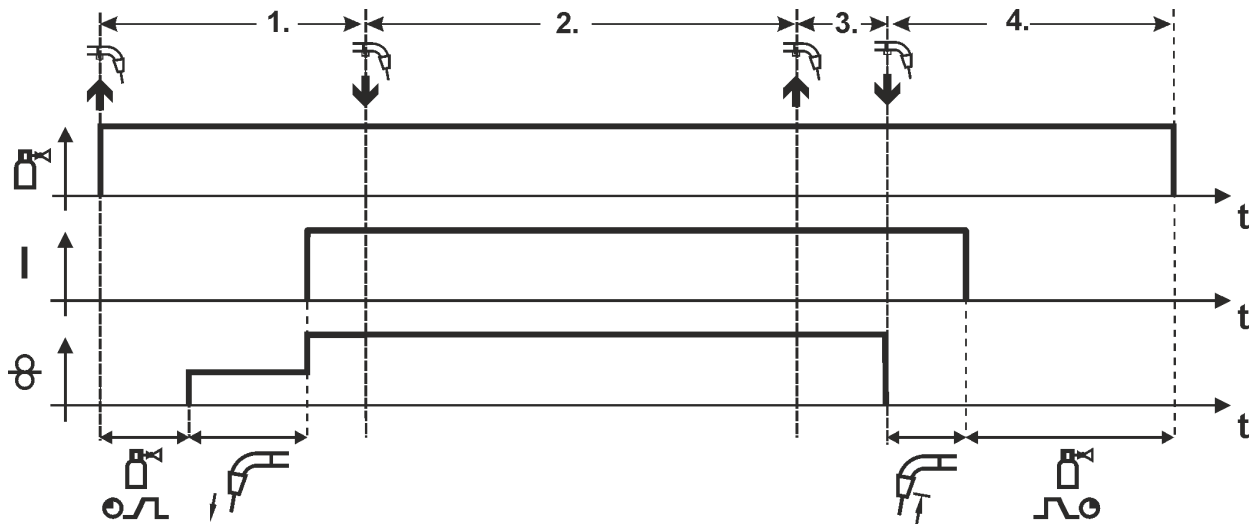

Figure 5-27

### Step 1

- Press and hold torch trigger
- Shielding gas is expelled (gas pre-flows)
- Wire feed motor runs at "creep speed".
- Arc ignites after the wire electrode makes contact with the workpiece; welding current flows.
- Change over to pre-selected WF speed (main program P<sub>A</sub>).

### Step 2

- Release torch trigger (no effect)

### Step 3

- Press torch trigger (no effect)

### Step 4

- Release torch trigger
- WF motor stops.
- Arc is extinguished after the preselected wire burn-back time expires.
- Gas post-flow time elapses.

## Latched mode with superpulse

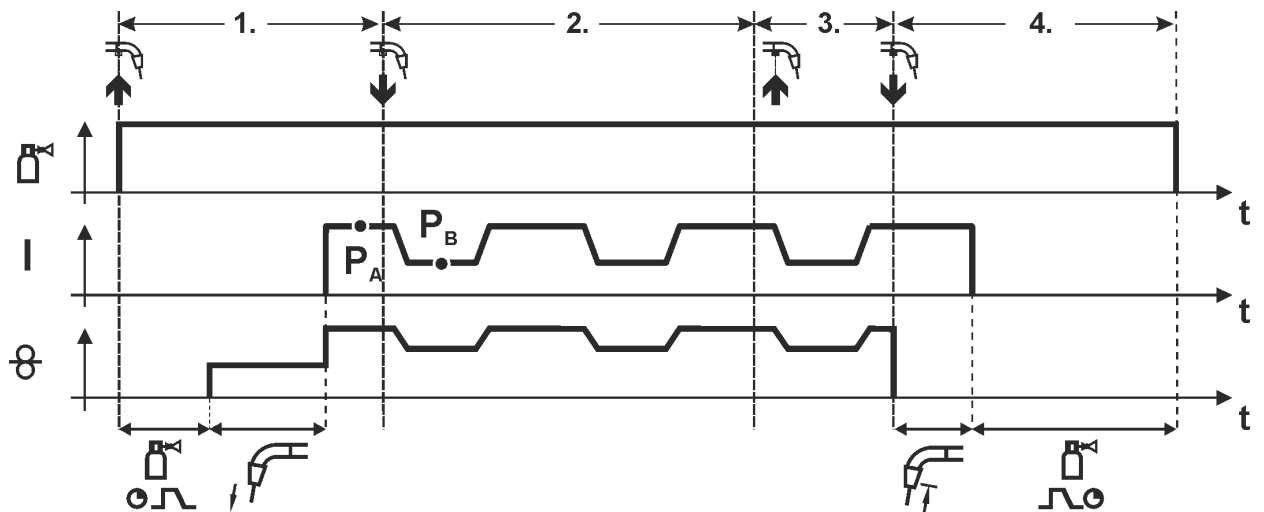

Figure 5-28

### Step 1:

- Press and hold torch trigger
- Shielding gas is expelled (gas pre-flows)
- Wire feed motor runs at “creep speed”.
- Arc ignites after the wire electrode makes contact with the workpiece; welding current flows.
- Start the super pulse function beginning with main program  $P_A$ .  
The welding parameters change at the specified times between main program  $P_A$  and the reduced main program  $P_B$ .

### Step 2:

- Release torch trigger (no effect)

### Step 3:

- Press torch trigger (no effect)

### Step 4:

- Release torch trigger
- Super pulse function is ended.
- WF motor stops.
- Arc is extinguished after the preselected wire burn-back time expires.
- Gas post-flow time elapses.

## Latched with changing welding method (process switching)

To activate or set the function > see 5.4.4 chapter.

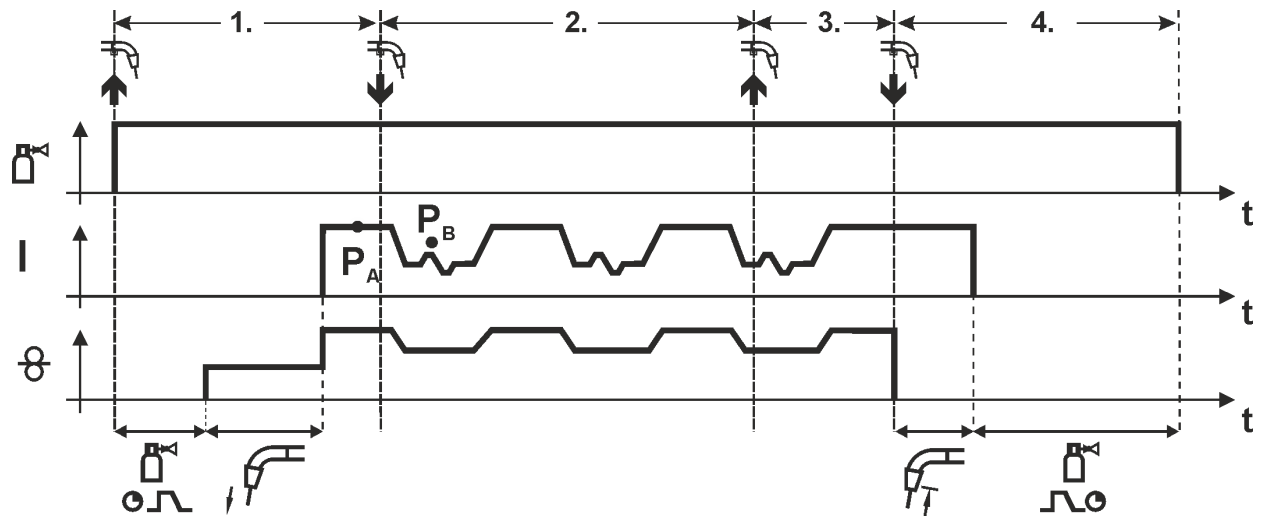

Figure 5-29

### 1st cycle:

- Press and hold torch trigger
- Shielding gas is expelled (gas pre-flows)
- Wire feed motor runs at "creep speed"
- Arc ignites after the wire electrode makes contact with the workpiece; welding current flows
- Start the process alternation starting with process  $P_A$ :  
The welding processes alternate between the process  $P_A$  stored in the JOB and the opposite process  $P_B$  at the specified times ( $t_2$  and  $t_3$ )

**If a standard process is stored in the JOB, this means that there is a permanent alternation between the processes, starting with the standard process and followed by the pulse process. The same applies if the situation is reversed.**

### 2nd cycle:

- Release torch trigger (no effect)

### 3rd cycle:

- Press torch trigger (no effect)

### 4th cycle:

- Release torch trigger
- Super pulse function is ended
- WF motor stops
- Arc is extinguished after the pre-selected wire burn-back time elapses
- Gas post-flow time elapses

**This function can be activated using the PC300.NET software.**

**Refer to the software operating instructions.**



## Latched special

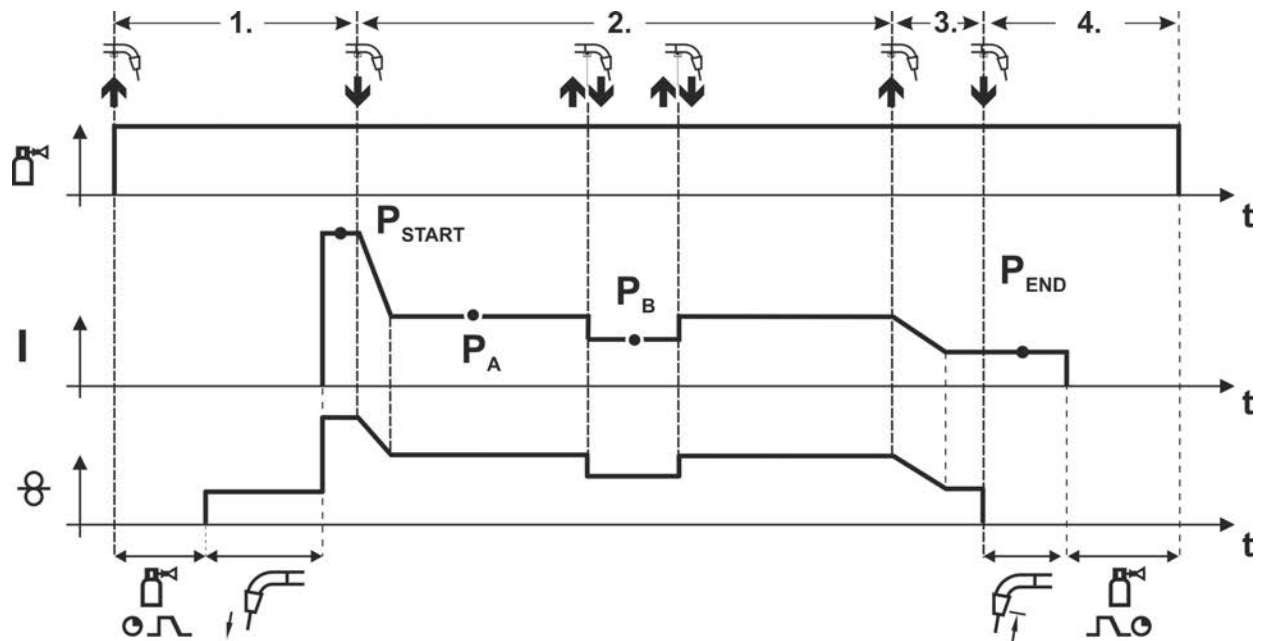

Figure 5-30

### Step 1

- Press and hold torch trigger
- Shielding gas is expelled (gas pre-flows)
- Wire feed motor runs at “creep speed”.
- Arc ignites after the wire electrode makes contact with the workpiece, welding current is flowing (start program  $P_{START}$ )

### Step 2

- Release torch trigger
- Slope to main program  $P_A$ .

The slope on main program  $P_A$  is given at the earliest after the set time  $t_{START}$  elapses and at the latest when the torch trigger is released.

Tapping<sup>1)</sup> can be used to change over to the reduced main program  $P_B$ .

Repeated tapping will switch back to the main program  $P_A$ .

### Step 3

- Press and hold torch trigger
- Slope to end program  $P_{END}$ .

### Step 4

- Release torch trigger
- WF motor stops.
- Arc is extinguished after the preselected wire burn-back time expires.
- Gas post-flow time elapses.

<sup>1)</sup> Prevent tapping (brief press and release within 0.3 seconds)

If the welding current is to be prevented from switching over to the reduced main program  $P_B$  by tapping, the parameter value for WF3 needs to be set to 100% ( $P_A = P_B$ ) in the program sequence.

## Special latched with changing welding method by tapping (process switching)

To activate or set the function > see 5.4.4 chapter.

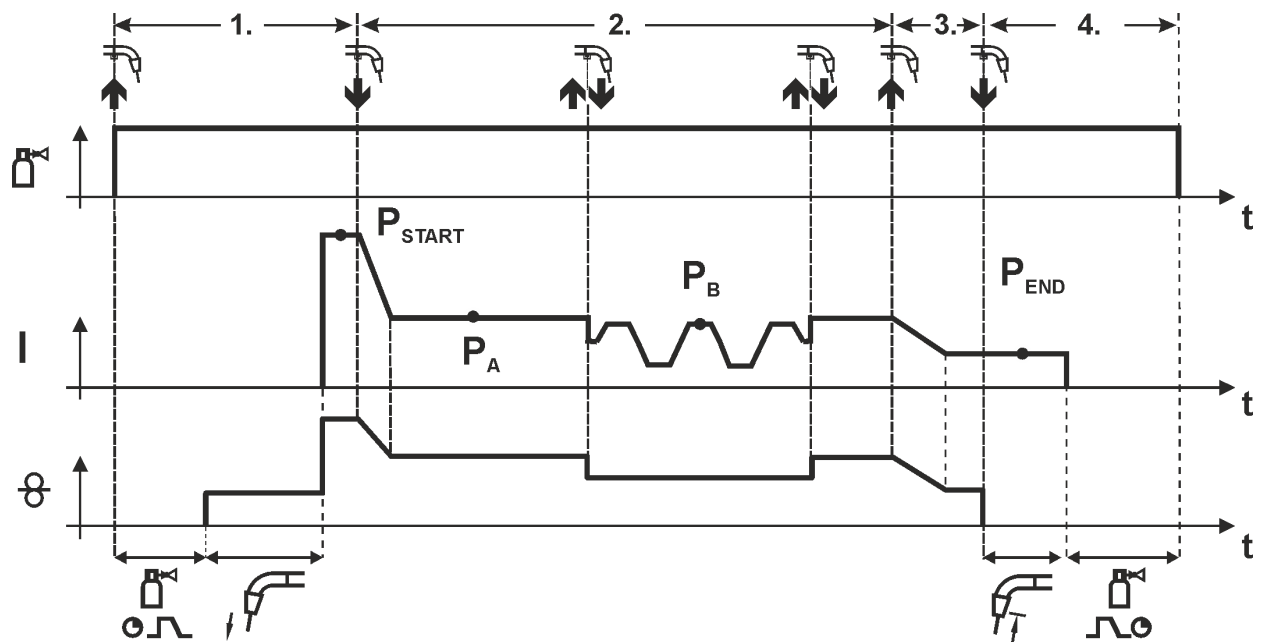

Figure 5-31

### 1st cycle

- Press and hold torch trigger.
- Shielding gas is expelled (gas pre-flows)
- Wire feed motor runs at "creep speed"
- Arc ignites after the wire electrode makes contact with the workpiece, welding current is flowing (start program  $P_{START}$ )

### 2nd cycle

- Release torch trigger
- Slope on main program  $P_A$

The slope on main program  $P_A$  is given at the earliest after the set time  $t_{START}$  elapses and at the latest when the torch trigger is released.

Tapping (pressing the torch trigger for less than 0.3 sec.) changes over the welding process ( $P_B$ ).

If a standard process has been defined in the main program, tapping changes to the pulse process, and tapping again will return to the standard process, etc.

### 3rd cycle

- Press and hold torch trigger
- Slope to end program  $P_{END}$

### 4th cycle

- Release torch trigger
- WF motor stops
- Arc is extinguished after the pre-selected wire burn-back time elapses
- Gas post-flow time elapses

This function can be activated using the PC300.NET software.

Refer to the software operating instructions.

### Special latched with changing welding method (process switching)

To activate or set the function > see 5.4.4 chapter.

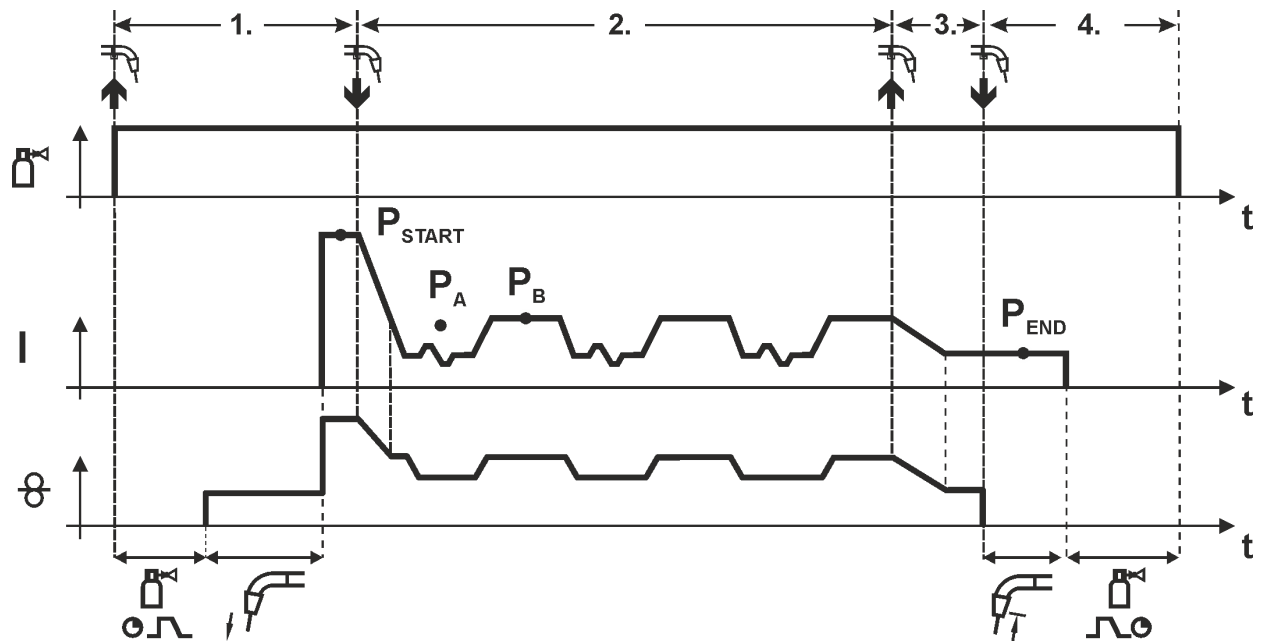

Figure 5-32

#### 1st cycle

- Press and hold torch trigger
- Shielding gas is expelled (gas pre-flows)
- Wire feed motor runs at "creep speed"
- Arc ignites after the wire electrode makes contact with the workpiece, welding current is flowing (start program  $P_{START}$  for the time  $t_{start}$ )

#### 2nd cycle

- Release torch trigger
- Slope on main program  $P_A$
- Start the process alternation starting with process  $P_A$ :  
The welding processes alternate between the process  $P_A$  stored in the JOB and the opposite process  $P_B$  at the specified times ( $t_2$  and  $t_3$ )

**If a standard process is stored in the JOB, this means that there is a permanent alternation between the processes, starting with the standard process and followed by the pulse process. The same applies if the situation is reversed.**

#### 3<sup>rd</sup> cycle

- Press the torch trigger
- Super pulse function is ended
- Slope in the end program  $P_{END}$  for the time  $t_{end}$

#### 4th cycle

- Release torch trigger
- WF motor stops
- Arc is extinguished after the pre-selected wire burn-back time elapses
- Gas post-flow time elapses

To activate or set the function > see 5.4.4 chapter.

For machine versions with pulsed arc welding procedures only.

This function can be activated using the PC300.NET software.

Refer to the software operating instructions.

## Special, latched with superpulse

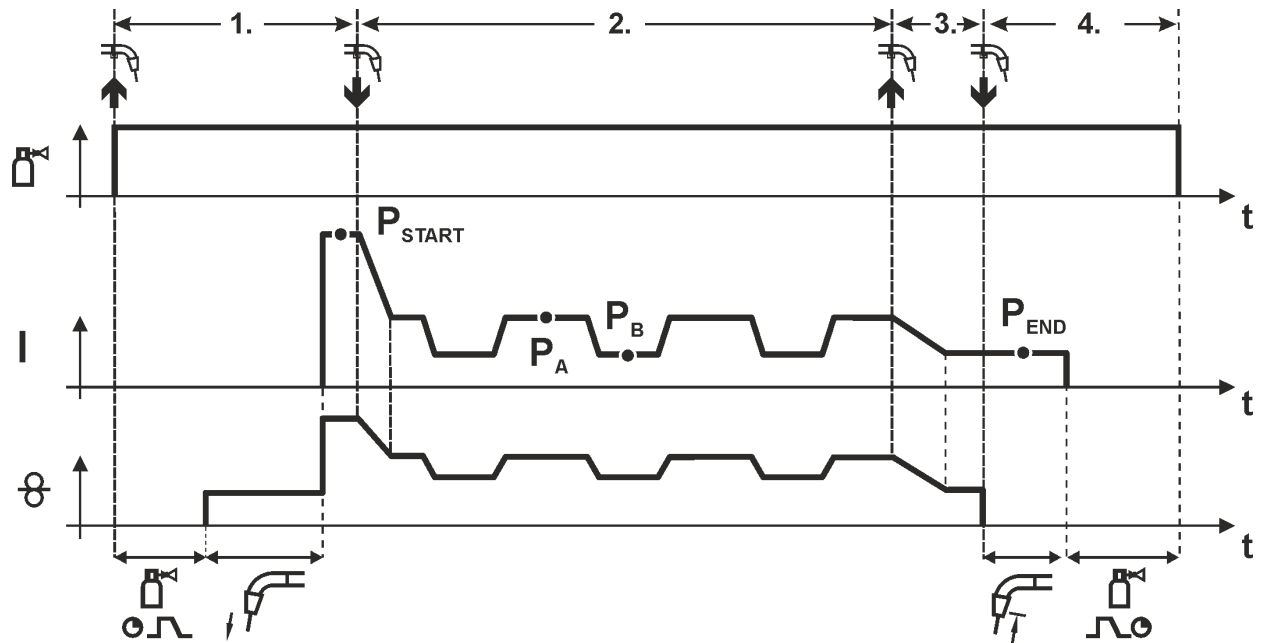

Figure 5-33

### Step 1

- Press and hold torch trigger
- Shielding gas is expelled (gas pre-flows)
- Wire feed motor runs at “creep speed”.
- Arc ignites after the wire electrode makes contact with the workpiece, welding current is flowing (start program  $P_{START}$  for the time  $t_{start}$ ).

### Step 2

- Release torch trigger
- Slope on main program  $P_A$ .
- Start the super pulse function beginning with main program  $P_A$ :  
The welding parameters change at the specified times between main program  $P_A$  and the reduced main program  $P_B$ .

### Step 3

- Press the torch trigger.
- Super pulse function is ended.
- Slope in the end program  $P_{END}$  for the time  $t_{end}$ .

### Step 4

- Release torch trigger
- WF motor stops.
- Arc is extinguished after the preselected wire burn-back time expires.
- Gas post-flow time elapses.

### 5.4.8 forceArc / forceArc puls

Heat-reduced, directionally-stable and powerful arc with deep fusion penetration for the upper power range.

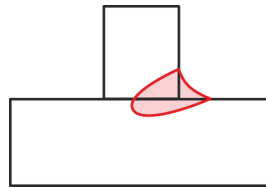

Figure 5-34

- Smaller included angle due to deep penetration and directionally stable arc
- Excellent root and sidewall fusion
- Secure welding also with very long stick-outs
- Reduced undercuts
- Manual and automated applications

You can make use of these properties after selecting the forceArc process > see 5.4.1 chapter.

**As with pulse arc welding, it is important to make sure of a good welding current connection.**

- Keep welding current cables as short as possible and ensure that cable cross-sections are adequate!
- Fully unroll welding current cables, torch hose packages and, if applicable, intermediate hose packages. Avoid loops!
- Use welding torches, preferably water-cooled, that are suitable for the higher power range.
- Use welding wire with adequate copper coating when welding steel. The wire spool should have layer spooling.

**Unstable arc!**

**Welding current cables that are not fully unrolled can cause faults in the arc (flickering).**

- **Fully unroll welding current cables, torch hose packages and, if applicable, intermediate hose packages. Avoid loops!**

## 5.4.9 wiredArc

Welding process with active wire control for stable and uniform penetration characteristics and perfect arc length stability, even in difficult applications and positional welding.

With a GMAW arc, the welding current (AMP) changes with the change of the stick-out. If, for instance, the stick-out is extended, the welding current decreases at constant wire feed speed (DG). Thus, the heat input into the workpiece (molten metal) decreases and the penetration reduces.

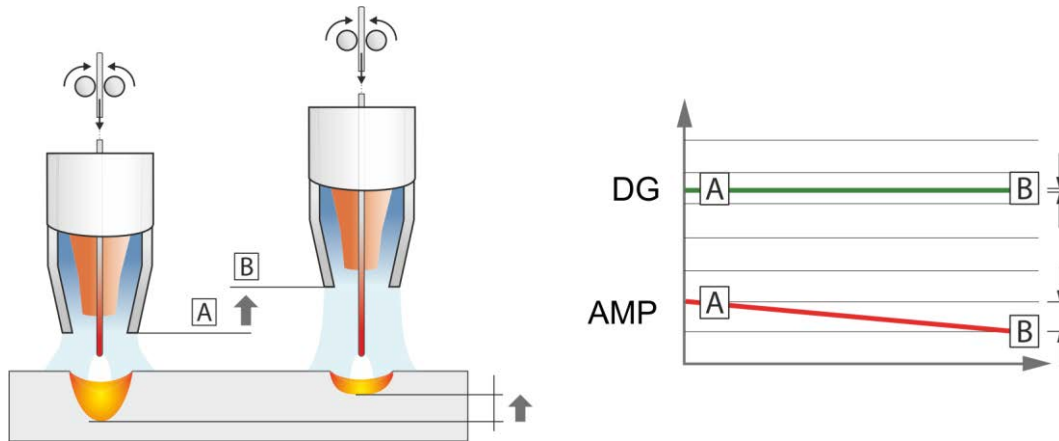

Figure 5-35

With the EWM wiredArc arc with wire control, the welding current (AMP) changes with the change of the stick-out only slightly. The compensation of the welding current takes place with an active control of wire feed speed (DG). If, for instance, the stick-out is extended, the wire feed speed will be increased. Due to this, the welding current remains almost constant and thus the heat input into the workpiece remains almost constant. As a result, the penetration changes with the change of the stick-out only slightly.

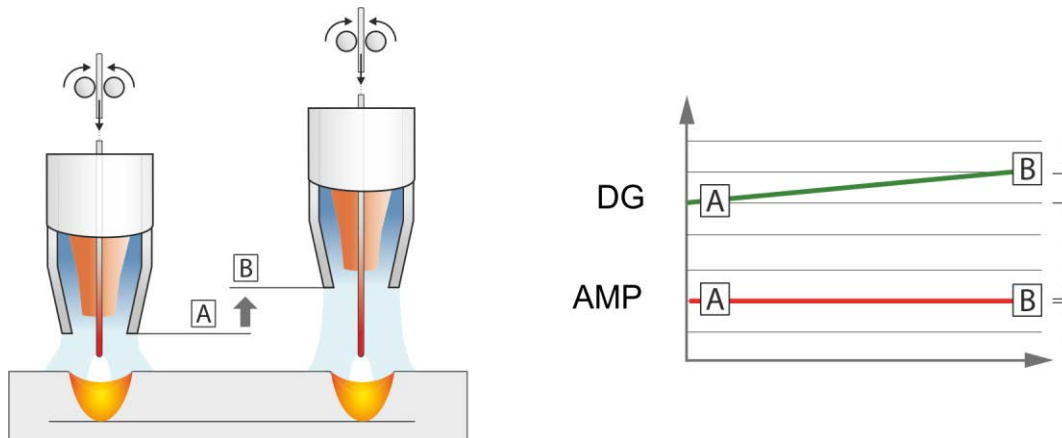

Figure 5-36

## 5.4.10 rootArc/rootArc puls

Short arc with perfect weld modelling capabilities for effortless gap bridging, especially for root welding



Figure 5-37

- Reduced spatter compared to standard short arc
- Good root formation and secure sidewall fusion
- Manual and automated applications

### Unstable arc!

**Welding current cables that are not fully unrolled can cause faults in the arc (flickering).**

- **Fully unroll welding current cables, torch hose packages and, if applicable, intermediate hose packages. Avoid loops!**

## 5.4.11 coldArc / coldArc puls

Heat-reduced, low-spatter short arc for high dimensional stability welding and brazing of thin metal sheets with excellent gap-bridging.



Figure 5-38

After selecting the coldArc process > see 5.4.1 chapter you benefit from:

- Less distortion and reduced discolouration thanks to minimised heat input
- Considerably reduced spatter thanks to virtually power-free material transfer
- Easy welding of the root passes in all plate thicknesses and in all positions
- Perfect gap bridging even with inconsistent gap widths
- Manual and automated applications

You can make use of these properties after selecting the coldArc process (see the "Selecting a MIG/MAG welding task" chapter).

With coldArc welding, it is important to ensure good quality wire feeding because of the welding filler materials being used!

- Equip the welding torch and torch hose package to suit the task! ( and the operating instructions for the welding torch.)

**This function can only be enabled with the PC300.NET software.**

**(See operating instructions for the software)**

## 5.4.12 Standard MIG/MAG torch

The MIG welding torch trigger is essentially used to start and stop the welding process.

Operating elements	Functions
 Torch trigger	<ul style="list-style-type: none"> <li>• Start/stop welding</li> </ul>

Additional functions such as program switching (before or after welding) are possible by tapping the torch trigger (depending on machine type and control configuration).

The following parameters must be configured accordingly in the menu Special Parameters > see 5.10 chapter .

## 5.4.13 MIG/MAG special-torches

**Function specifications and more indepth information can be found in the operating manual for the relevant welding torch!**

### 5.4.13.1 Program and up/down operation

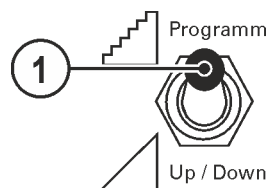





Figure 5-39

Item	Symbol	Description
1		<p><b>Welding torch function changeover switch (special welding torch required)</b></p> <p> Programm----- Changing over programs or JOBs</p> <p> Up / Down----- Infinite adjustment of welding performance.</p>

**Does not apply to wire feeders of the Drive XQ IC 200 series. These machines are configured for program mode. They do not have a changeover switch.**

## 5.4.13.2 Switching between Push/Pull and intermediate drive

### ⚠ WARNING



**No improper repairs and modifications!**

To prevent injuries and damage to the machine, only competent personnel (authorised service personnel) are allowed to repair or modify the machine.

**Unauthorised manipulations will invalidate the warranty!**

- Instruct competent personnel (authorised service personnel) to repair the machine.



**Dangers resulting from failure to perform test after conversion!**

Before reconnection, “Inspection and Testing during Operation” according to IEC/BS EN 60974-4 “Arc welding systems – Inspection and Testing during Operation” has to be performed!

- Perform test to IEC / DIN EN 60974-4!

The plugs are located directly on the M3.7X printed circuit board.

Plug	Function
on X24	Operation with Push/Pull welding torch (factory setting)
on X23	Operation with intermediate drive

## 5.5 TIG welding

### 5.5.1 Welding task selection

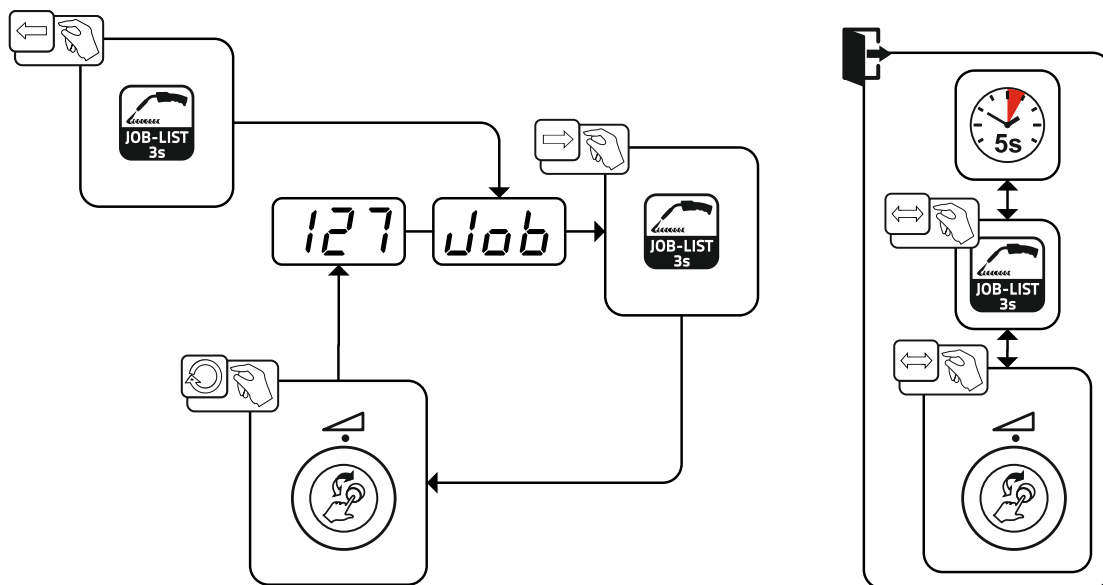

Figure 5-40

### 5.5.2 Welding current setting

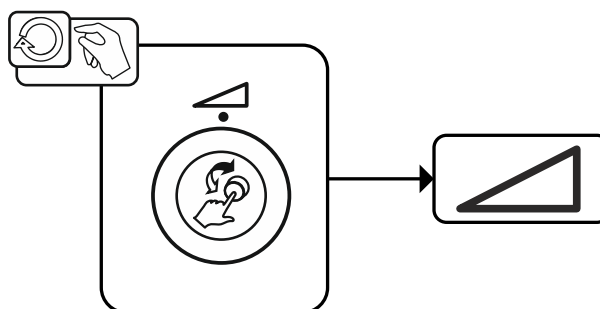

Figure 5-41



### 5.5.3 Arc ignition

#### 5.5.3.1 Liftarc

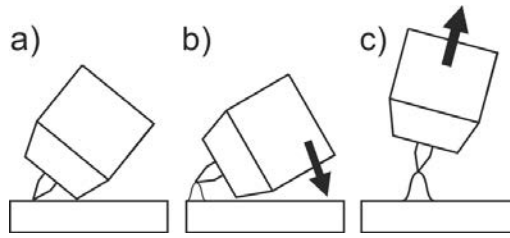

Figure 5-42











The arc is ignited on contact with the workpiece:

- a) Carefully place the torch gas nozzle and tungsten electrode tip onto the workpiece and press the torch trigger (liftarc current flowing, regardless of the main current set).
- b) Incline the torch over the torch gas nozzle to produce a gap of approx. 2-3 mm between the electrode tip and the workpiece. The arc ignites and the welding current is increased, depending on the operating mode set, to the ignition or main current set.
- c) Lift off the torch and swivel to the normal position.

Ending the welding process: Release or press the torch trigger depending on the operating mode selected.

## 5.5.4 Operating modes (functional sequences)

### 5.5.4.1 Explanation of signs and functions

Symbol	Meaning
	Press torch trigger
	Release torch trigger
	Tap torch trigger (press briefly and release)
	Shielding gas flowing
I	Welding output
	Gas pre-flows
	Gas post-flows
	Non-latched
	Special, non-latched
	Latched
	Special, latched
t	Time
P <sub>START</sub>	Ignition program
P <sub>A</sub>	Main program
P <sub>B</sub>	Reduced main program
P <sub>END</sub>	End program
t <sub>s1</sub>	Slope duration from P <sub>START</sub> to P <sub>A</sub>

### 5.5.4.2 Automatic cut-out

Once the fault periods have elapsed, the automatic cut-out stops the welding process when it has been triggered by one of two states:

- During ignition  
5 s after the start of the welding process, no welding current flows (ignition error).
- During welding  
The arc is interrupted for more than 5 s (arc interruption).

## Non-latched mode

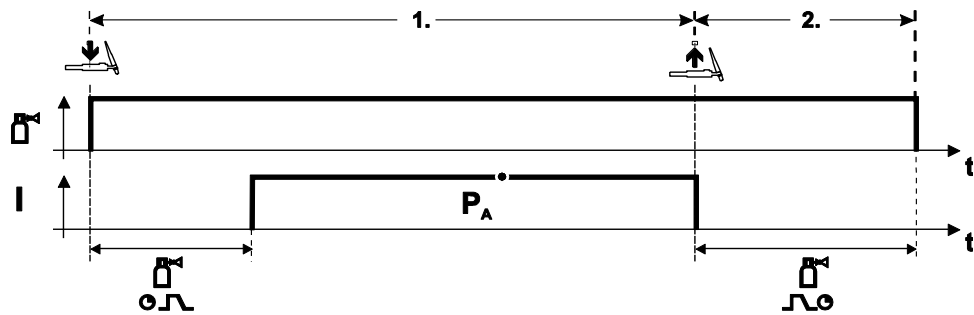

Figure 5-43

### Selection

- Select non-latched operating mode

#### Step 1

- Press and hold torch trigger.
- Shielding gas is expelled (gas pre-flows).

#### The arc is ignited using liftarc.

- Welding current flows with pre-selected setting.

#### Step 2

- Release torch trigger.
- Arc is extinguished.
- Gas post-flow time elapses.

### Special, non-latched

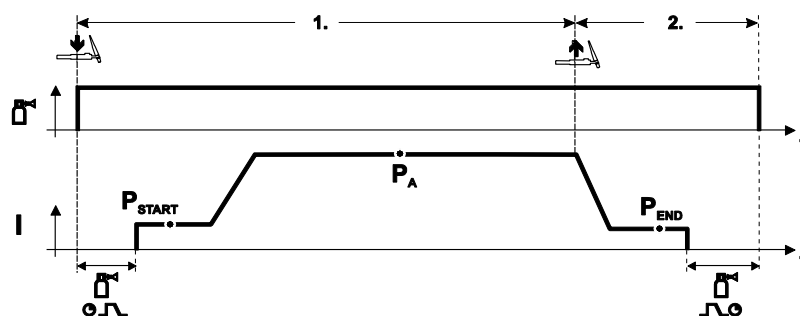

Figure 5-44

### Selection

- Select non-latched special mode

#### Step 1

- Press and hold torch trigger
- Shielding gas is expelled (gas pre-flows)

#### The arc is ignited using liftarc.

- Welding gas flows with pre-selected setting in start program "P<sub>START</sub>".
- After the "t<sub>start</sub>" start current time elapses, the welding current rises with the set upslope time "t<sub>S1</sub>" to the main program "P<sub>A</sub>".

#### Step 2

- Release torch trigger.
- The welding current reduces with the downslope time "t<sub>Se</sub>" to the end program "P<sub>END</sub>".
- After the end current time "end" elapses, the arc will extinguish.
- Gas post-flow time elapses.

## Latched mode

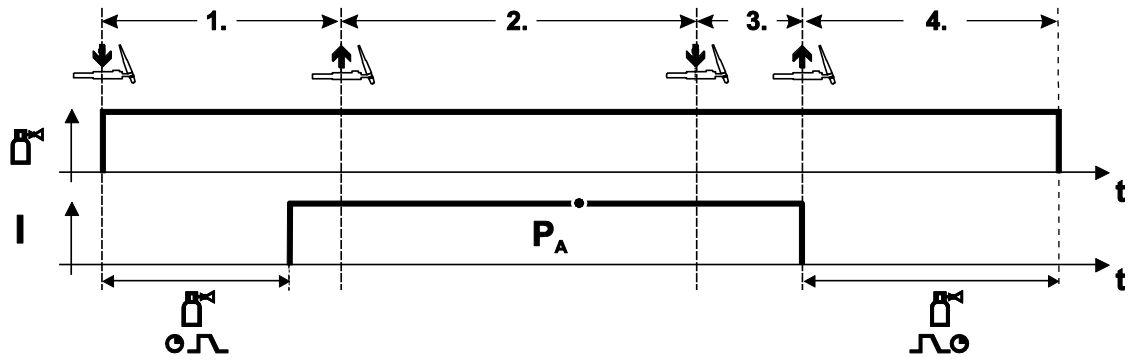

Figure 5-45

### Selection

- Select latched operating mode

#### Step 1

- Press and hold torch trigger
- Shielding gas is expelled (gas pre-flows)

#### The arc is ignited using liftarc.

- Welding current flows with pre-selected setting.

#### Step 2

- Release torch trigger (no effect)

#### Step 3

- Press torch trigger (no effect)

#### Step 4

- Release torch trigger
- Arc is extinguished.
- Gas post-flow time elapses.

## Latched special

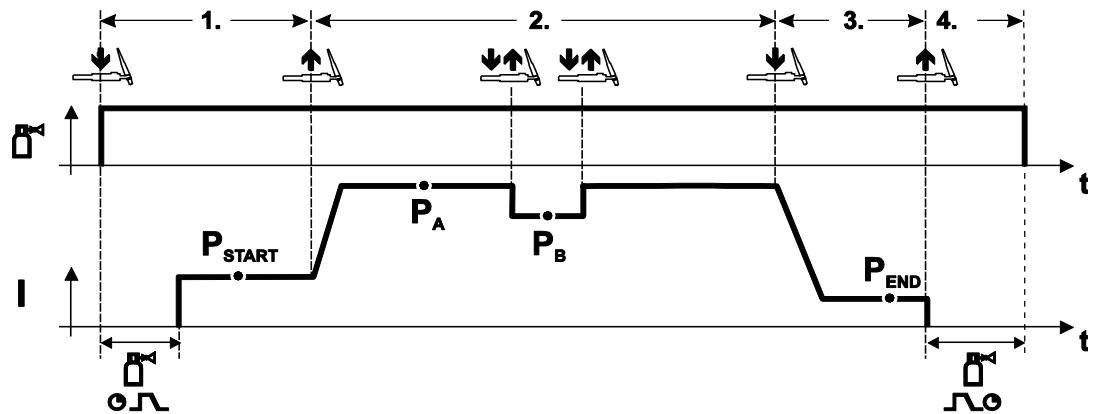



Figure 5-46

## Selection

- Select latched special mode .

## Step 1

- Press and hold torch trigger.
- Shielding gas is expelled (gas pre-flows).

## The arc is ignited using liftarc.

- Welding gas flows at pre-selected setting in start program "P<sub>START</sub>".

## Step 2

- Release torch trigger.
- Slope on main program "P<sub>A</sub>".

The slope on main program P<sub>A</sub> is given at the earliest after the set time  $t_{START}$  elapses and at the latest when the torch trigger is released.

Tapping can be used to switch to the reduced main program "P<sub>B</sub>". Repeated tapping will switch back to the main program "P<sub>A</sub>".

## Step 3

- Press the torch trigger.
- Slope to end program "P<sub>END</sub>".

## Step 4

- Release torch trigger.
- Arc is extinguished.
- Gas post-flow time elapses.

## 5.6 MMA welding

### 5.6.1 Welding task selection

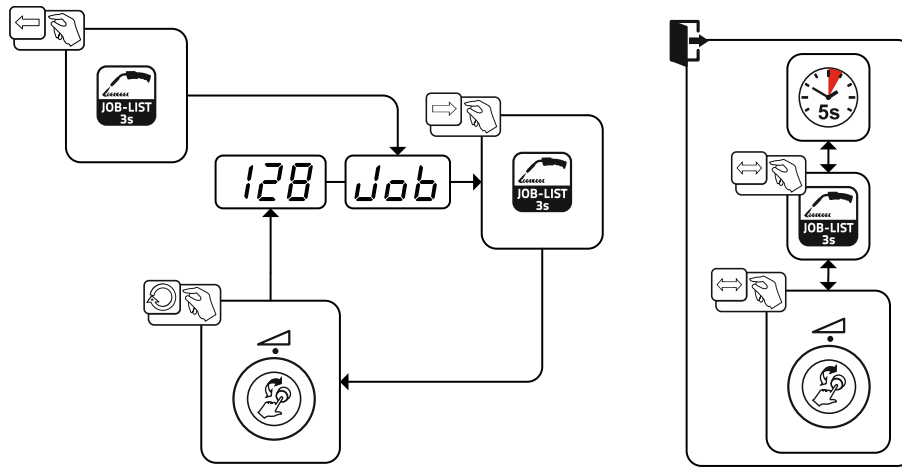

Figure 5-47

### 5.6.2 Welding current setting

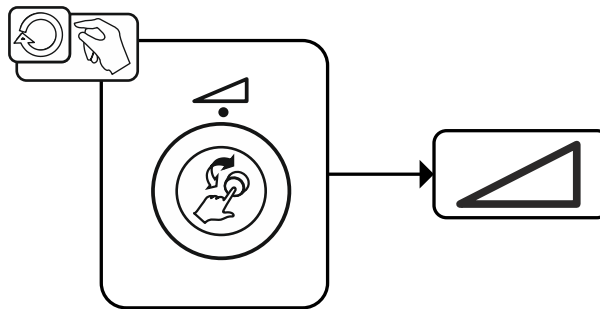

Figure 5-48

### 5.6.3 Arcforce

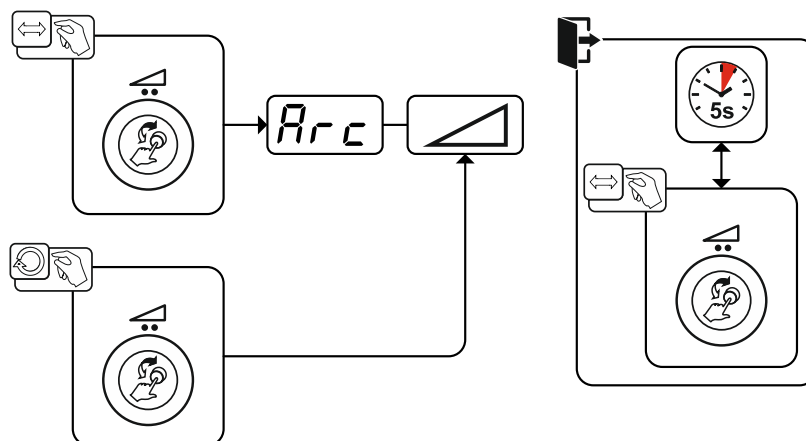

Figure 5-49

Setting:

- Negative values: rutile electrode types
- Values at zero: basic electrode types
- Positive values: cellulose electrode types

## 5.6.4 Hotstart

The function hot start ensures a secure igniting of the arc and a sufficient heating to the still cold parent metal at the beginning of the welding process. The ignition takes place here with increased current (hot start current) over a certain time (hot start time).

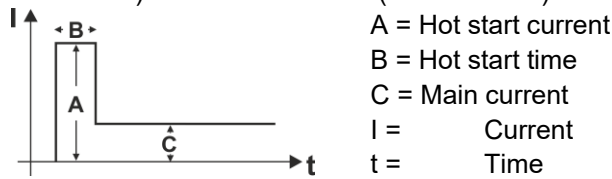

Figure 5-50

### 5.6.4.1 Hotstart current

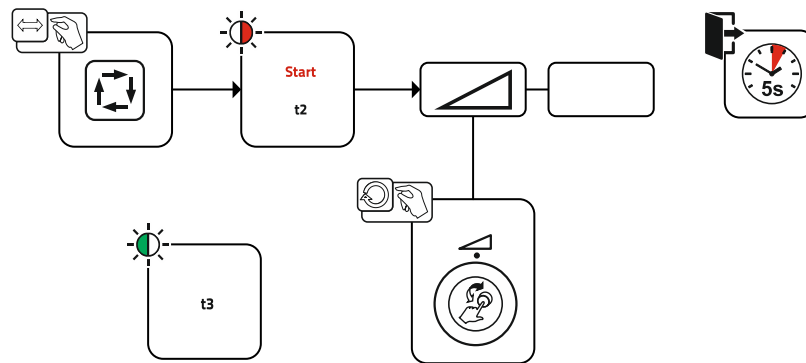

Figure 5-51

### 5.6.4.2 Hotstart time

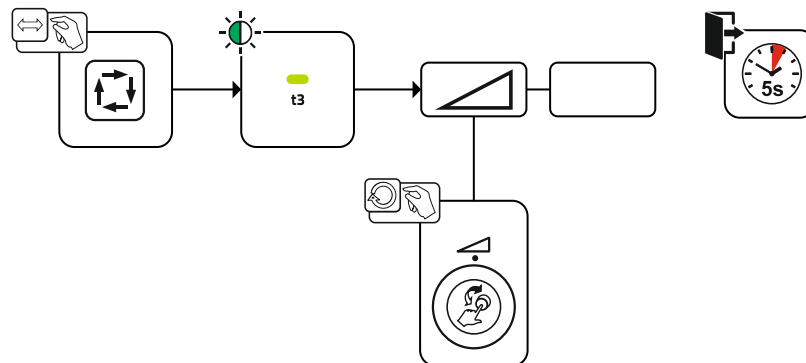
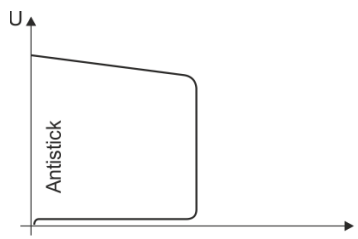

Figure 5-52

## 5.6.5 Antistick



**The Antistick feature prevents the electrode from annealing.**

Should the electrode stick despite the Arcforce feature, the machine automatically switches to the minimum current within approx. one second. This prevents the electrode from annealing. Check the welding current setting and correct for the welding task in hand.

Figure 5-53

## 5.7 Options (additional components)

Does not apply to wire feeders of the Drive XQ IC 200 series.

### 5.7.1 Electronic gas flow control (OW DGC)

The connected gas line has to have a preset pressure of 3–5 bar.

The electronic gas flow control (DGC) regulates the optimum gas flow rate for the respective welding process (optimally preset from the factory). This helps avoid welding errors caused by too much (gas blast) or insufficient shielding gas (shielding gas cylinder empty or gas supply interrupted).

The required gas flow rate can be controlled by the user and corrected if necessary (nominal values before welding). In addition, when used in combination with Xnet software (optional), the exact gas consumption can be recorded.

The parameter is selected by pressing the parameter display push-button on the right side. The signal light "D" is illuminated. The value units can be in litres per minute "l/min" or Cubic Feet Per Hour "cFH" (adjustable with special parameters P29 > see 5.10 chapter). During the welding process, these nominal values are compared with the actual values. If these values differ more than the specified error threshold (special parameters P28) the error message "Err 8" is output and the continuous welding process is stopped.

### 5.7.2 Wire reserve sensor (OW WRS)

Minimizes the risk of seam errors due to early detection and display (signal light "End") with about 10 % remaining wire. At the same time, the forward-looking production allows the reduction of the auxiliary process times.

### 5.7.3 Wire spool heater (OW WHS)

Prevention of condensation on the welding wire due to adjustable temperature (special parameters P26 > see 5.10.3.23 chapter) of the wire spool heater.

## 5.8 Access control

To prevent people from unauthorised or inadvertent changing of the welding parameters at the machine, entering values on the control can be blocked by using the key switch.

With the key switch in position , all functions and parameters can be configured without any restriction.

In the key position  the following functions or parameters can not be changed:

- No adjustment of the operating point (welding power) in programs 1 - 15.
- No change of welding type or operating mode in programs 1 - 15.
- No welding task switching (JOB block operation P16 is possible).
- No change of special parameters (except P10). Restart is required.

Saving or deleting favourites is locked.

## 5.9 Voltage reducing device

Only machine variants with the (VRD/SVRD/AUS/RU) code are equipped with a voltage reduction device (VRD). The VRD is used for increased safety, especially in hazardous environments such as shipbuilding, pipe construction or mining.

A VRD is mandatory in some countries and required by many on-site safety instructions for power sources.

The VRD > see 4 chapter signal light is illuminated when the voltage reduction device is operating without fault and the output voltage is reduced to a value specified in the relevant standard (see technical data).

## 5.10 Special parameters (advanced settings)

Special parameters (P1 to Pn) are applied for customer-specific configuration of machine functions. This allows the user maximum flexibility in optimising their requirements.

These settings are not configured directly on the machine control since a regular setting of the parameters is generally not required. The number of selectable special parameters can deviate between the machine controls used in the welding system (also see the relevant standard operating instructions).

If required, the special parameters can be reset to the factory settings > see 5.10.2 chapter.



## 5.10.1 Selecting, changing and saving parameters

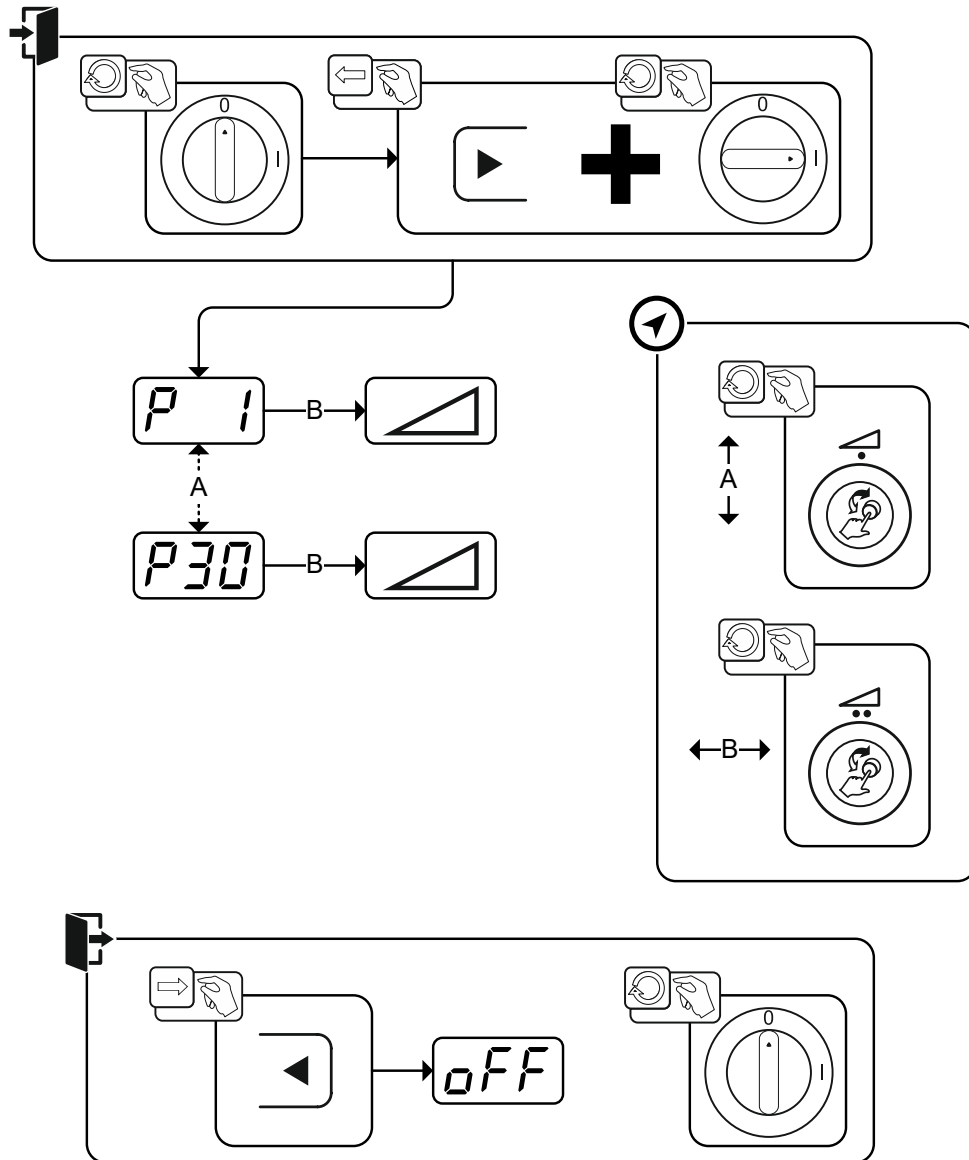

Figure 5-54

Display	Setting/selection
	<b>Wire inching / wire return ramp time</b> 0 = ----- normal inching (10 s ramp time) 1 = ----- fast inching (3 s ramp time) (ex works)
	<b>Block program "0"</b> 0 = ----- P0 enabled 1 = ----- P0 blocked (Ex works)
	<b>Display mode for Up/Down welding torch with one-digit 7-segment display (two keys)</b> 0 = ----- normal display (ex works) program number/welding power (0–9) 1 = ----- display toggles between program number/welding type
	<b>Program limitation</b> Programs 1 to max. 15 Ex works: 15
	<b>Special cycle in the special latched and non-latched operating modes</b> 0 = ----- normal (previous) non-latched/latched (Ex works) 1 = ----- WF3 cycle for non-latched/latched

# Functional characteristics

Special parameters (advanced settings)



Display	Setting/selection
<b>P 7</b>	<b>Correction operation, threshold value setting</b> 0 = ----- correction operation switched off (Ex works) 1 = ----- correction operation on "Main program (PA)" flashing
<b>P 8</b>	<b>Program switching with standard welding torch</b> 0 = No program switching (factory setting) 1 = ----- Special latched 2 = ----- Special latched (n-cycle active) 3 = ----- Special latched (n-cycle sequence from any program)
<b>P 9</b>	<b>Tapping start for latched and special latched operation</b> 0 = ----- no 4-cycle inching start 1 = ----- 4-cycle inching start possible (ex works)
<b>P 10</b>	<b>One or two-wire feed operation</b> 0 = ----- single operation (Ex works) 1 = ----- dual operation, this unit is the "master" 2 = ----- dual operation, this unit is the "slave"
<b>P 11</b>	<b>Special latched tapping time</b> 0 = tapping function switched off 1 = 300ms (Ex works) 2 = 600ms
<b>P 12</b>	<b>JOB list changeover</b> 0 = ----- task-oriented JOB list 1 = ----- actual JOB list (Ex works) 2 = ----- actual JOB list, JOB changeover activated via accessories
<b>P 13</b>	<b>Lower limit remote JOB switching</b> JOB range of the function torches (PM 2U/D, PM RD2) Lower limit: 129 (ex works)
<b>P 14</b>	<b>Upper limit remote JOB switching</b> JOB area of the function torch (PM 2U/D, PM RD2) Upper limit: 169 (ex works)
<b>P 15</b>	<b>HOLD function</b> 0 = ----- HOLD values are not displayed 1 = ----- HOLD values are displayed (Ex works)
<b>P 16</b>	<b>Block JOB mode</b> 0 = ----- Block JOB mode not enabled (Ex works) 1 = ----- Block JOB mode enabled
<b>P 17</b>	<b>Program selection with standard torch trigger</b> 0 = ----- no program selection (Ex works) 1 = ----- program selection possible
<b>P 19</b>	<b>Average value display for superPuls</b> 0 = ----- Function switched off. 1 = ----- Function switched on (ex factory).
<b>P 20</b>	<b>Predefined pulse arc welding process in the PA program</b> 0 = ----- Predefined pulse arc welding process in the PA program is disabled. 1 = ----- If the superPuls and welding process switching functions are available and activated, the pulse arc welding process is always executed in the main program PA (ex factory).
<b>P 21</b>	<b>Predefined absolute value for relative programs</b> Start program (P <sub>START</sub> ), down-slope program (P <sub>B</sub> ) and end program (P <sub>END</sub> ) can be set relative to the main program (P <sub>A</sub> ) or in an absolute manner, as desired. 0 = ----- Relative parameter setting (ex factory) 1 = ----- Absolute parameter setting

Display	Setting/selection
	<b>Electronic gas flow control, type</b> 1 = ----- type A (ex works) 0 = ----- type B
	<b>Program settings for relative programs</b> 0 = ----- Combined setting of relative programs possible (ex works). 1 = ----- Individual setting of relative programs possible (ex works).
	<b>Correction or nominal voltage display</b> 0 = ----- Correction voltage display (ex works). 1 = ----- Absolute nominal voltage display.
	<b>JOB selection in Expert mode</b> Without function in this machine version.
	<b>Nominal value of wire spool heater (OW WHS) &gt; see 5.10.3.23 chapter</b> off = switched off Temperature setting range: 25°C - 50°C (45°C ex works)
	<b>Operating mode switching at welding start &gt; see 5.10.3.24 chapter</b> 0 = ----- Not enabled (ex works) 1 = ----- Enabled
	<b>Error threshold of electronic gas flow control &gt; see 5.10.3.25 chapter</b> Error output in case of gas nominal value deviation
	<b>Unit system &gt; see 5.10.3.26 chapter</b> 0 = ----- metric system (ex works) 1 = ----- Imperial system
	<b>Selection option for program sequence with rotary knob &gt; see 5.10.3.27 chapter</b> 0 = ----- Not enabled 1 = ----- Enabled (ex works)

## 5.10.2 Reset to factory settings

All special parameters saved by the user will be overwritten by the factory settings!

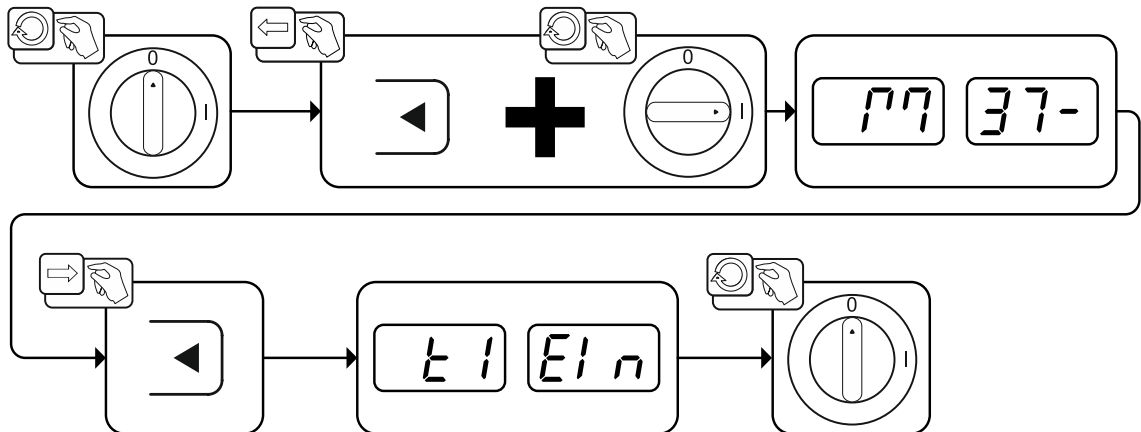

Figure 5-55

## 5.10.3 Special parameters in detail

### 5.10.3.1 Ramp time for wire inching (P1)

The wire inching starts with a speed 1.0 m/min for 2 secs. It is subsequently increased to a ramp function to 6.0 m/min. The ramp time can be set between two ranges.

During wire inching, the speed can be changed by means of the welding power rotary knob. Changing the speed has no effect on the ramp time.

### 5.10.3.2 Program "0", releasing the program block (P2)

The program P0 (manual setting) is blocked. Only operation with P1-P15 is possible, irrespective of the key switch position.

### 5.10.3.3 Display mode for Up/Down welding torch with one-digit 7-segment display (P3)

**Normal display:**

- Program mode: Program number
- Up/down operation: Welding power (0=minimum current/9=maximum current)

**Toggling display:**

- Program mode: Program number and welding procedure (P=pulse/n=not pulse) are toggled
- Up/down operation: Welding power (0=minimum current/9=maximum current) and symbol for up/down operation are toggled

### 5.10.3.4 Program limit (P4)

Program selection can be limited with the special parameter P4.

- The setting is adopted for all JOBs.
- Program selection depends on the position of the "welding torch function" changeover switch > see 5.4.13 chapter.

Programs can only be switched when the changeover switch is in the "program" position.

- Programs can be switched by means of a connected remote control or special welding torch.
- If a special welding torch or a remote control is not connected, it is only possible to switch programs by means of the "arc length correction/select welding program" rotary dial > see 4 chapter.

### 5.10.3.5 Special cycle in the operating modes special latched and non-latched (P5)

With the special sequence activated, the start of the welding process changes as follows:

**Sequence for special non-latched mode/special latched mode:**

- Start program "P<sub>START</sub>"
- Main program "P<sub>A</sub>"

**Sequence for special non-latched mode/special latched mode with custom sequence activated:**

- Start program "P<sub>START</sub>"
- Reduced main program "P<sub>B</sub>"
- Main program "P<sub>A</sub>"

### 5.10.3.6 Correction operation, threshold value setting (P7)

The correction operation is switched on and off for all JOBs and their programs at the same time. A correction operation is specified for wire speed (DV) and welding voltage correction (U<sub>korr</sub>) for each JOB. The correction value is saved separately for each program. The correction range can be maximum 30% of the wire speed and +/-9.9 V welding voltage.

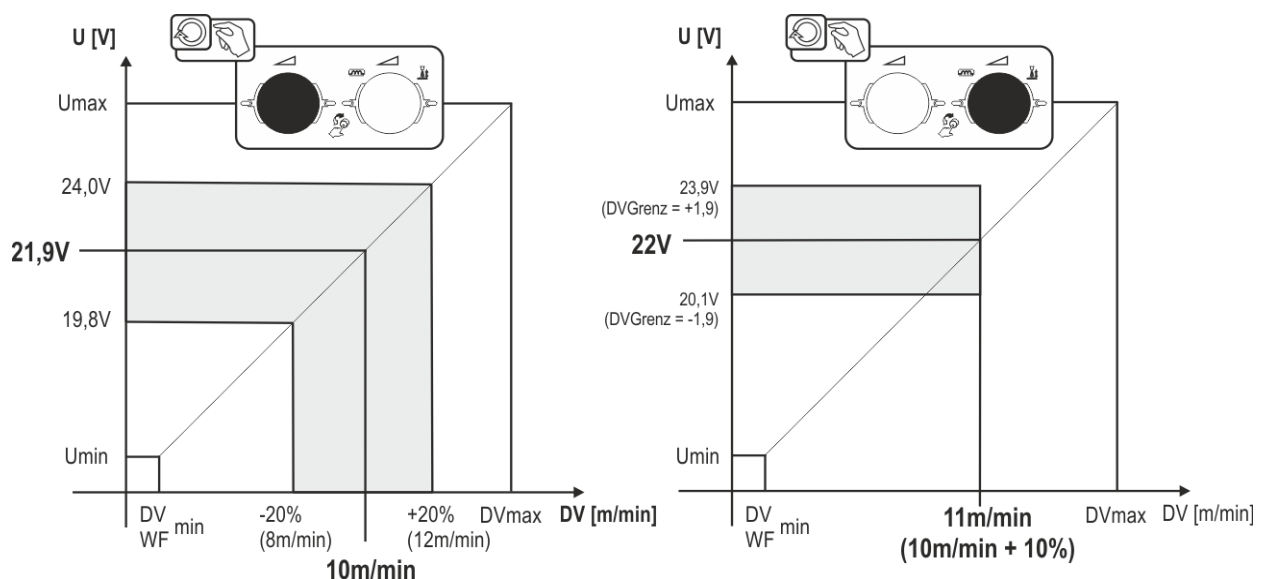



Figure 5-56

### Example for the operating point in correction operation:

The wire feed speed in a program (1 to 15) is set to 10.0 m/min. This corresponds to a welding voltage (U) of, for example, 21.9 V. When the key switch is now turned to position , welding can only be carried out with these values in this program.

If the welder is also to carry out wire and voltage correction in program mode, correction operation must be switched on and limit values for wire and voltage must be specified.

Setting the correction limit for wire = 20 %.

Setting the correction limit for voltage = 1.9 V.

The wire feed speed can now be corrected by 20% (8.0 to 12.0 m/min) and the welding voltage by +/- 1.9 V (3.8 V).

In the example, the wire feed speed is set to 11.0 m/min. This corresponds to a welding voltage of 22 V. Now the welding voltage can be corrected by 1.9 V (20.1 V and 23.9 V).

**When the key switch is turned to position , the values for voltage and wire feed speed correction are reset.**

### Setting the correction range:

- Activate the special parameter "Correction operation" (P7=1) and save > see 5.10.1 chapter.
- Key switch to position .
- Set the correction range as follows:

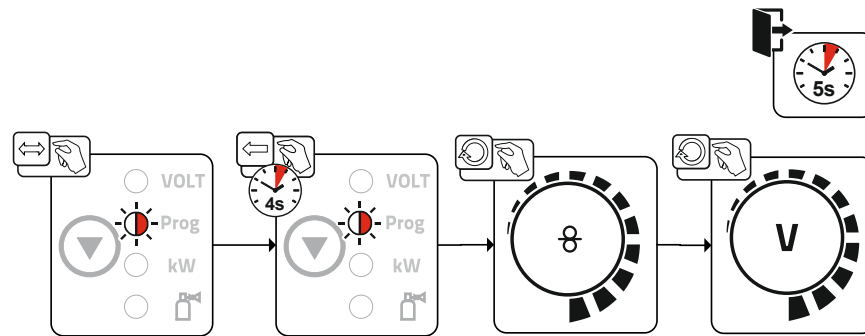



Figure 5-57

- If the user is inactive for about 5 seconds, the pre-set values will be applied and the display switches back to the program display.
- Turn the key switch back to position .

## 5.10.3.7 Switching programs with the standard torch trigger (P8)

### Special latched (latched absolute program sequence)

- Cycle 1: absolute program 1 is run
- Cycle 2: absolute program 2 is run after completion of "tstart".
- Cycle 3: absolute program 3 is run until the "t3" time has elapsed. The program then switches automatically to absolute program 4.

**Accessory components such as remote controls or special torches may not be connected!  
Program switching at the wire feed unit control is disabled.**

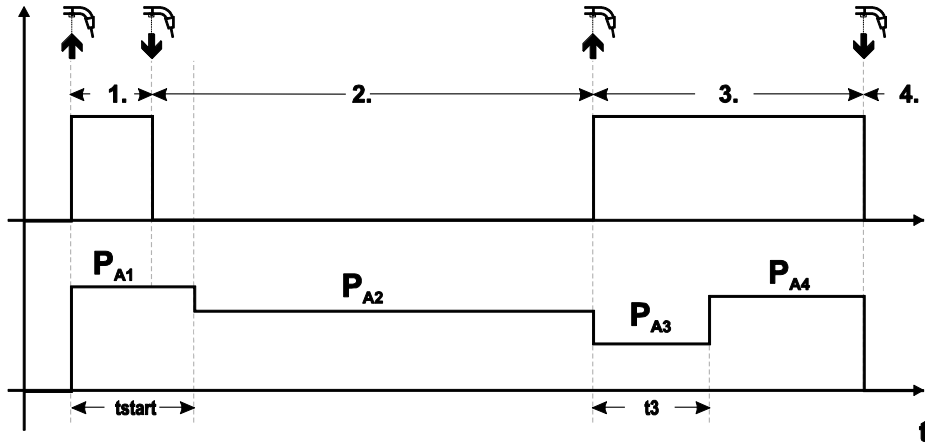

Figure 5-58

### Specific latched special (n cycle)

In the n cycle program sequence, the unit starts in the 1st cycle with start program P<sub>start</sub> from P<sub>1</sub>. In the second cycle, the machine switches to absolute program 2, once the start time "tstart" has elapsed. Tapping switches to other programs (P<sub>A1</sub> to max. P<sub>A9</sub>).

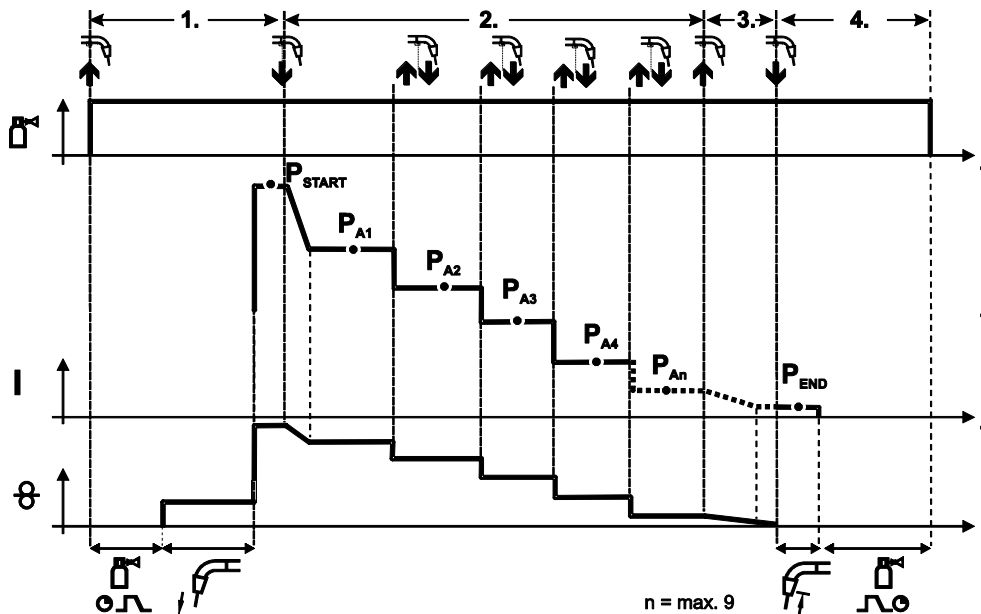

Figure 5-59

The number of programs ( $P_{An}$ ) corresponds to the cycle number specified under N cycle.

#### 1st cycle

- Press and hold torch trigger.
- Shielding gas is expelled (gas pre-flows).
- Wire feed motor runs at "creep speed".
- Arc ignites after the wire electrode makes contact with the workpiece, welding current is flowing (start program  $P_{START}$  from  $P_{A1}$ )

#### 2nd cycle

- Release torch trigger.
- Slope to main program  $P_{A1}$ .

The slope to main program  $P_{A1}$  is given at the earliest after the set time  $t_{START}$  elapses and at the latest when the torch trigger is released. Tapping (pressing briefly and releasing within 0.3 sec) can switch to other programs. Programs  $P_{A1}$  to  $P_{A9}$  are possible.

#### 3rd cycle

- Press and hold torch trigger.
- Slope to end program  $P_{END}$  from  $P_{AN}$ . The program can be stopped at any time by pressing the torch trigger longer than 0.3 sec.  $P_{END}$  from  $P_{AN}$  is then executed.

#### 4th cycle

- Release torch trigger.
- WF motor stops.
- Arc is extinguished after the pre-selected wire burn-back time elapses.
- Gas post-flow time elapses.

#### Special latched (n-cycle sequence from any program)

The function specification is the same as for n-cycle active (parameter setting 2) with the difference that after Pstart, the program selected before the welding start follows and not  $P_{A1}$ . This setting can also be combined with P17.

#### 5.10.3.8 Latched/special-latched tap start (P9)

In latched – tap start – operating mode it is possible to switch straight to the second step by tapping the torch trigger; it is not necessary for current to be flowing.

The welding can be halted by pressing the torch trigger for a second time.

#### 5.10.3.9 "Single or dual operation" (P10) setting

If the system is fitted with two wire feeds, no further accessory components may be operated on the 7-pole connection socket (digital)! This relates to digital remote controls, robot interfaces, documentation interfaces, welding torches with digital control lead connection, etc.

No second wire feed may be connected in single operation ( $P10 = 0$ )!

- Remove connections to the second wire feed

In dual operation ( $P10 = 1$  or  $2$ ), both wire feed units must be connected and configured differently on the controls for this operating mode!

- Configure one wire feed unit as the master ( $P10 = 1$ )
- Configure the other wire feed unit as a slave ( $P10 = 2$ )

Wire feed units with key switches (optional, > see 5.8 chapter) must be configured as masters ( $P10 = 1$ ).

The wire feed configured as the master is active after the welding machine is switched on. There are no other functional differences between the wire feeds.

#### 5.10.3.10 Latched special tapping time setting (P11)

The tapping time for changing over between the main program and reduced main program can be set in three levels.

0 = no tapping

1 = 320ms (factory setting)

2 = 640ms

## 5.10.3.11 JOB list switching (P12)

Value	Name	Explanation
0	Task-based JOB list	JOB numbers are sorted by welding wires and shielding gases. When selecting, the JOB numbers may be skipped.
1	Real JOB list	JOB numbers correspond to the actual memory cells. Every job can be selected, there will be no memory cells if the selection will be skipped.
2	Real JOB list, JOB switching active	Like real JOB list. In addition JOB switching with appropriate accessory components such as a function torch is possible.

### Creating user-defined JOB lists

**An associated memory area, in which switching with accessory components such as a function torch between JOBs is possible, is created.**

- Set special parameters P12 to "2".
- Set switch "Program or Up/Down Function" to "Up/Down" position.
- Select existing JOB, which comes as close as possible to the desired result.
- Copy JOB to one or more destination JOB numbers.

If JOB parameters still need to be adjusted, select destination JOBs one after the other and adjust parameters individually.

- Special parameters P13 to the lower limit and
- Adjust special parameters P14 to the upper limit of the destination JOBs.
- Set switch "Program or Up/down function" to position "Program".

With the accessory component JOBs can be switched in the specified range.

### Copying JOBs, "Copy to" function

**The possible target range is between 129 - 169.**

- First configure special parameter P12 to P12 = 2 or P12 = 1!

### Copy JOB by number, see corresponding operating instructions ("Control").

By repeating the last two steps, the same source JOB can be copied to multiple target JOBs.

If the control does not register any user activity for longer than 5 seconds, the parameter display is shown once more and the copy process is complete.

## 5.10.3.12 Lower and upper limits of the remote JOB changeover process (P13, P14)

The highest and lowest JOB numbers which can be selected using accessory components, such as the PowerControl 2 torch.

Avoids an accidental changeover into undesirable or undefined JOBs.

## 5.10.3.13 Hold function (P15)

### Hold function active (P15 = 1)

- Average values for the last main program parameters used for welding are displayed.

### Hold function not active (P15 = 0)

- Setpoint values for the main program parameters are displayed.



### 5.10.3.14 Block JOB mode (P16)

The following accessory components support block JOB mode:

- Up/Down welding torch with one-digit 7-segment display (two keys)

Program 0 is always active in JOB 0 and program 1 in all other JOBs

In this operating mode, up to 30 JOBs (welding tasks) divided into three blocks can be called up with accessory components.

The following configurations must be carried out to use the block JOB operation:

- Set the "Program or Up/Down function" changeover switch to "Program"
- Set the JOB list to actual JOB list (special parameter P12 = "1")
- Enable block JOB mode (special parameter P16 = "1")
- Switch to block JOB mode by selecting one of the special JOBs 129, 130 or 131.

**Simultaneous operation with interfaces such as RINT X11, BUSINT X11, DVINT X11 or digital accessory components like the R40 remote control is not possible!**

**Allocation of JOB numbers to the display on the accessory components**

JOB no.	Display/selection on the accessory component									
	0	1	2	3	4	5	6	7	8	9
Special JOB 1	129	141	142	143	144	145	146	147	148	149
Special JOB 2	130	151	152	153	154	155	156	157	158	159
Special JOB 3	131	161	162	163	164	165	166	167	168	169

#### JOB 0:

This JOB allows the manual setting of the welding parameters.

The selection of JOB 0 can be prevented by using the key switch or with the parameter "Block program 0" (P2).

Key switch position  or special parameter P2 = 0: JOB 0 blocked.

Key switch position  or special parameter P2 = 1: JOB 0 can be selected.

#### JOBS 1-9:

In each special JOB, nine JOBs (see Table) can be called up.

Nominal values for wire feed speed, arc correction, dynamics, etc. must be stored in advance in these JOBs. This is done conveniently using the software PC300.Net.

If the software is not available, the "Copy to" function can be used to create user-defined JOB lists in the special JOB areas (see explanations in the Chapter "JOB list switching (P12)").

### 5.10.3.15 Selecting programs with the standard torch trigger (P17)

Allows you to select a program or switch a program before starting welding.

You switch to the next program by tapping the torch trigger. Once the last enabled program is reached, you start again at the beginning.

- Program 0 is the first enabled program, provided that it is not blocked. (see also special parameter P2).
- The last enabled program is P15.
  - If the programs are not limited by special parameter P4 (see special parameter P4).
  - Or if the programs are limited for the selected JOB by the n cycle setting (see parameter P8).
- Welding starts when the torch trigger is held for longer than 0.64 s.

You can select programs with the standard torch trigger in all operating modes (non-latched, special non-latched, latched and special latched).

### 5.10.3.16 Average value display for superPuls (P19)

#### Function active (P19 = 1)

- For superPuls, the performance average value from program A (P<sub>A</sub>) and program B (P<sub>B</sub>) is shown on the display (ex factory).

#### Function inactive (P19 = 0)

- Only the performance of program A is displayed for superPuls.

**If the function is enabled and only "000" is shown on the machine display, this is a rare case of an incompatible system set-up. Solution: Disable special parameter P19.**

## 5.10.3.17 Predefined execution of the pulsed arc welding process in the PA program (P20)

For machine versions with pulsed arc welding procedures only.

### Function active (P20 = 1)

- If the superPuls and welding process switching functions are available and activated, the pulse arc welding process is always executed in the main program PA (ex factory).

### Function inactive (P20 = 0)

- Predefined execution of the pulse arc welding process in the PA program is disabled.

## 5.10.3.18 Predefined absolute value for relative programs (P21)

Start program ( $P_{START}$ ), down-slope program ( $P_B$ ) and end program ( $P_{END}$ ) can be set relative to the main program ( $P_A$ ) or in an absolute manner, as desired.

### Function active (P21 = 1)

- Absolute parameter setting

### Function inactive (P21 = 0)

- Relative parameter setting (ex factory)

## 5.10.3.19 Electronic gas flow control, type (P22)

Active only in machines with integrated gas flow control (option ex works).

Adjustment may only be carried out by authorised service personnel (basic setting = 1).

## 5.10.3.20 Program settings for relative programs (P23)

The start, down-slope and end program relative programs can be set individually or combined for the P0-P15 operating points. When choosing the combined setting, in contrast to the individual setting, the parameter values are saved in the JOB. With the individual setting, the parameter values are identical for all JOBs (except for special JOBs SP1, SP2 and SP3).

## 5.10.3.21 Correction or nominal voltage display (P24)

When setting the arc correction using the right-hand rotary knob the display will either show the correction voltage +/- 9.9 V (ex works) or the absolute nominal voltage.

## 5.10.3.22 JOB selection in Expert mode (P25)

The special parameter P25 can be used to specify whether the special JOBs SP1/2/3 or the welding job selection according to the JOB list can be selected on the wire feeder.

## 5.10.3.23 Nominal value wire heater (P26)

The Wire Heating System (WHS) prevents moisture deposits on the welding wire and thus reduces the risk of pinholes. The setting is infinitely variable in the temperature range from 25°C to 50°C; the factory setting of 45°C is mainly used for moisture-attracting welding consumables such as aluminium or flux-cored wire.

## 5.10.3.24 Mode switching at welding start (P27)

With the selected 4-cycle-Special mode, the user can determine by the time of the torch trigger operation in which operating mode (4-cycle or 4-cycle-Special) the program sequence shall be carried out.

Hold torch trigger (longer than 300 ms): Program sequence with operating mode 4-cycle-Special (standard).

Tap torch trigger: Device changes to operating mode 4-cycle.

## 5.10.3.25 Error threshold electronic gas flow control (P28)

The set percentage value is the error threshold; if it is undershot or exceeded, an error message > see 5.7.1 chapter is displayed.

## 5.10.3.26 Units system (P29)

### Function not active

- Metric metric units are displayed.

### Function active

- Imperial units are displayed.

### 5.10.3.27 Selection option – Program sequence with welding power rotary knob (P30)

**Function not active**

- The rotary knob is locked, use the welding parameters push-button to select the welding parameters.

**Function active**

- Rotary knob can be used to select the welding parameters.

## 5.11 Machine configuration menu

### 5.11.1 Selecting, changing and saving parameters

Changes to the welding parameters are only possible if the key switch is set to key position . If the Xbutton function is activated, the key switch function is deactivated (see corresponding operating instructions "Control").

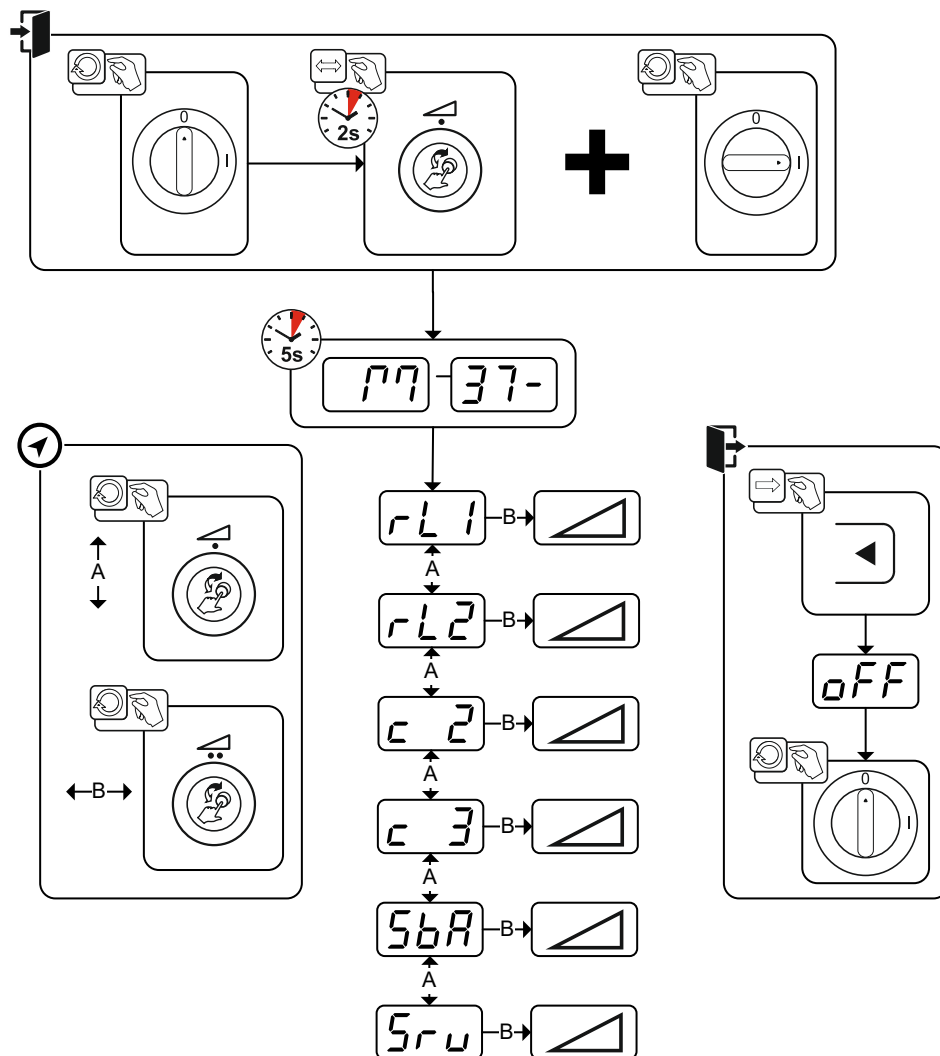

Figure 5-60

Display	Setting/selection
	<b>Lead resistance 1</b> Lead resistance for the first welding circuit 0 mΩ–60 mΩ (8 mΩ ex works).
	<b>Lead resistance 2</b> Lead resistance for the second welding circuit 0 mΩ–60 mΩ (8 mΩ ex works).
	<b>Only qualified service personnel may change the parameters!</b>
	<b>Only qualified service personnel may change the parameters!</b>

Display	Setting/selection
	<b>Time-based power-saving mode &gt; see 5.12 chapter</b> Time to activation of the power-saving mode in case of inactivity. Setting $\square F F$ = disabled or numerical value 5-60 min..
	<b>Service menu</b> Modifications to the service menu may only be carried out by authorised maintenance staff!

## 5.11.2 Aligning the cable resistance

The resistance value of cables can either be set directly or it can be aligned using the power source. The factory setting of the power sources is 8 m $\Omega$ . This value corresponds to a 5 m earth cable, a 1.5 m intermediate hose package and a 3 m water-cooled welding torch. With other hose package lengths, it is necessary to carry out a +/- voltage correction to optimise welding properties. The voltage correction value can be set close to zero by means of realigning the cable resistance. It is recommended to align the electric cable resistance after replacing accessories such as torches or intermediate hose packages.

In case a second wire feeder is used the (rL2) parameter has to be aligned. For all other configurations it is sufficient to align the (rL1) parameter.

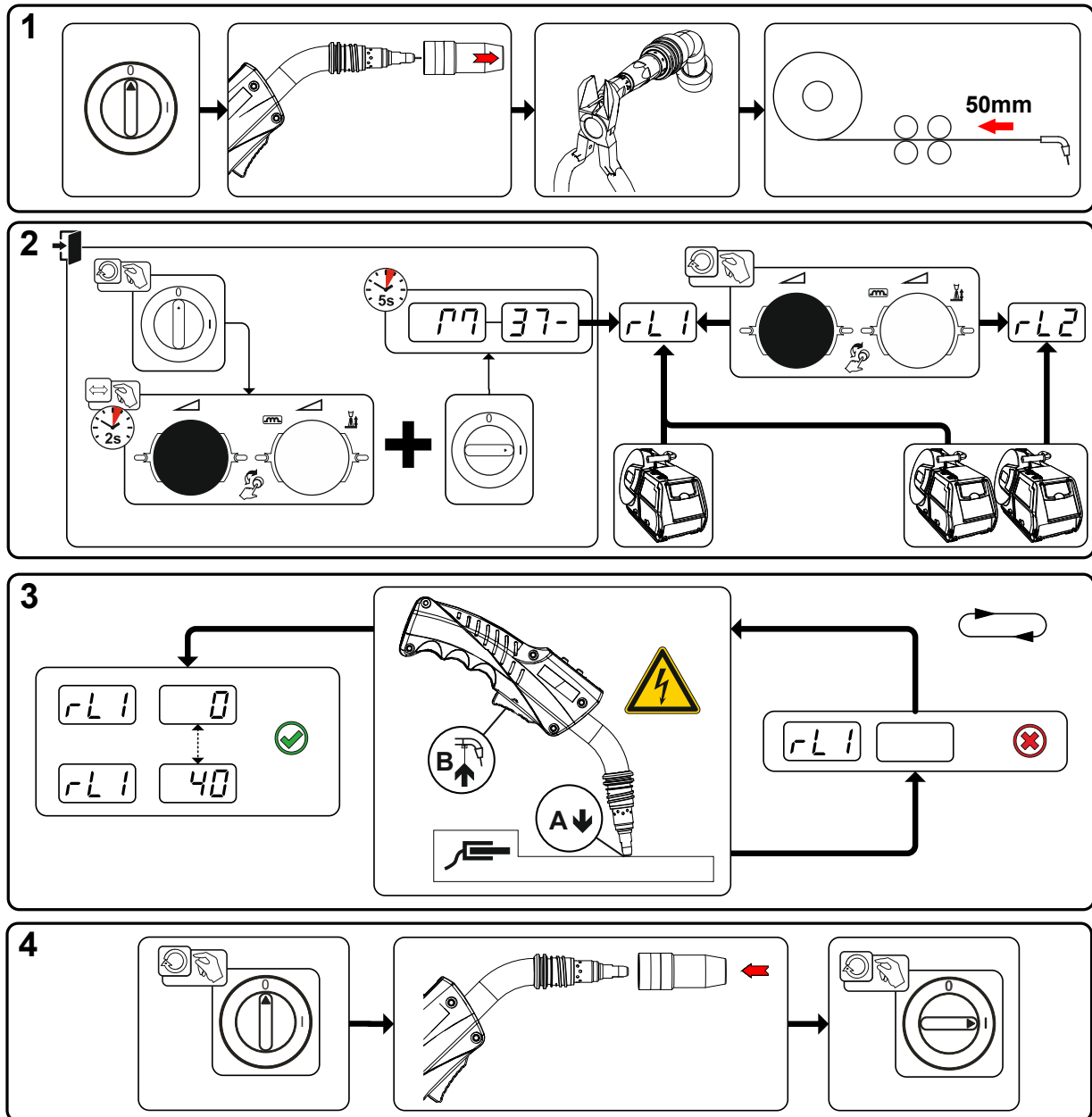

Figure 5-61

### 1 Preparation

- Switch off the welding machine.
- Unscrew the gas nozzle from the welding torch.
- Trim the welding wire so that it is flush with the contact tip.
- Retract the welding wire a little (approx. 50 mm) on the wire feeder. There should now be no more welding wire in the contact tip.

### 2 Configuration

- Press and hold "Welding power rotary knob", at the same time switch on the welding machine (at least 2 s). Release rotary knob (device changes after a further 5 s to the first parameter cable resistance 1).
- Turn the "Welding power rotary knob" to select the appropriate parameter. Parameter rL1 must be adjusted for all machine combinations. In case of welding systems with a second power circuit – if two wire feeders are to be operated from a single power source, for example – a second adjustment with parameter rL2 must be performed.

### 3 Alignment/Measurement

- Applying slight pressure, put the welding torch in place with the contact tip on a clean, purged location on the workpiece and then press the torch trigger for approx. 2 seconds. A short-circuit current will flow briefly, which is used to determine and display the cable resistance. The value can be between 0 mΩ and 40 mΩ. The new value is immediately saved without requiring further confirmation. If no value is shown on the right-hand display, then measurement failed. The measurement must be repeated.

### 4 Restoring welding standby mode

- Switch off the welding machine.
- Screw the gas nozzle onto the welding torch.
- Switch on the welding machine.
- Insert the welding wire.

## 5.12 Power-saving mode (Standby)

Using the parameter  $\overline{5bR}$  in the machine configuration menu, the time for the power-saving mode can be set or the mode can be deactivated > see 5.11 chapter.

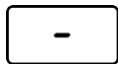

When power-saving mode is activated, the machine displays show the horizontal digit in the centre of the display only.

Actuating any operating element (e.g., turning a rotary knob) cancels the power-saving mode and the machine switches back to ready-to-weld mode.

## 6 Maintenance, care and disposal

### 6.1 General

#### **DANGER**



**Risk of injury due to electrical voltage after switching off!**

**Working on an open machine can lead to fatal injuries!**

**Capacitors are loaded with electrical voltage during operation. Voltage remains present for up to four minutes after the mains plug is removed.**

1. Switch off machine.
2. Remove the mains plug.
3. Wait for at least 4 minutes until the capacitors have discharged!

#### **WARNING**



**Improper maintenance, testing and repairs!**

**Maintenance, testing and repair of the machine may only be carried out by skilled and qualified personnel (authorised service personnel). A competent person is someone who, based on training, knowledge and experience, can recognize the hazards and possible consequential damage that may occur when testing power sources and can take the necessary safety precautions.**

- Follow the maintenance instructions.
- If any of the test requirements below are not met, the unit must not be put back into operation until it has been repaired and tested again.

Repair and maintenance work may only be performed by qualified authorised personnel; otherwise the right to claim under warranty is void. In all service matters, always consult the dealer who supplied the machine. Return deliveries of defective equipment subject to warranty may only be made through your dealer. When replacing parts, use only original spare parts. When ordering spare parts, please quote the machine type, serial number and item number of the machine, as well as the type designation and item number of the spare part.

Under the specified ambient conditions and normal working conditions this machine is essentially maintenance-free and requires just a minimum of care.

Contamination of the machine may impair service life and duty cycle. The cleaning intervals depend on the ambient conditions and the resulting contamination of the machine. The minimum interval is every six months.

## 6.2 Disposing of equipment



### Proper disposal!

The machine contains valuable raw materials, which should be recycled, and electronic components, which must be disposed of.

- Do not dispose of in household waste!
- Observe the local regulations regarding disposal!

In addition to the national or international regulations mentioned below, it is mandatory to follow the respective national laws and regulations on disposal.

- According to European provisions (Directive 2012/19/EU on Waste of Electrical and Electronic Equipment), used electric and electronic equipment may no longer be placed in unsorted municipal waste. It must be collected separately. The symbol depicting a waste container on wheels indicates that the equipment must be collected separately.

This machine has to be disposed of, or recycled, in accordance with the waste separation systems in use.

According to German law (law governing the distribution, taking back and environmentally correct disposal of electrical and electronic equipment (ElektroG)), used machines are to be placed in a collection system separate from unsorted municipal waste. The public waste management utilities (communities) have created collection points at which used equipment from private households can be disposed of free of charge.

The deletion of personal data is the responsibility of the end user.

Lamps, batteries or accumulators must be removed and disposed of separately before disposing of the device. The type of battery or accumulator and its composition is marked on the top (type CR2032 or SR44). The following EWM products may contain batteries or accumulators:

- Welding helmets  
Batteries or accumulators are easy to remove from the LED cassette.
- Device controls  
Batteries or accumulators are located on the back of these in corresponding sockets on the circuit board and are easy to remove. The controls can be removed using standard tools.

Information on returning used equipment or collections can be obtained from the respective municipal administration office. Devices can also be returned to EWM sales partners across Europe.

Further information on the topic of the disposal of electrical and electronic equipment can be found on our website at: <https://www.ewm-group.com/de/nachhaltigkeit.html>.

## 7 Rectifying faults

All products are subject to rigorous production checks and final checks. If, despite this, something fails to work at any time, please check the product using the following flowchart. If none of the fault rectification procedures described leads to the correct functioning of the product, please inform your authorised dealer.



### 7.1 Software version of the machine control

The query of the software versions only serves to inform the authorised service staff. It is available in the machine configuration menu > see 5.11 chapter.

### 7.2 Error messages (power source)

**The possible error numbers displayed depend on the machine series and version!**

Depending on the options of the machine display, a fault is shown as follows:

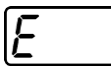
Display type - machine control	Display
Graphic display	
two 7-segment displays	
one 7-segment display	

The possible cause of the fault is signalled by a corresponding fault number (see table). In the case of an error, the power unit shuts down.

- Document machine errors and inform service staff as necessary.
- If multiple errors occur, these are displayed in succession.

#### Reset error (category legend)

<sup>A</sup> The error message disappears when the error is eliminated.

<sup>B</sup> The error message can be reset by pressing a push-button ◀.

All other error messages can only be reset by switching the machine off and on again.

#### Error 3: Tacho error

Categories A, B

- ✓ Fault in the wire feeder.
  - ✘ Check the electrical connections (connectors, lines).
- ✓ Permanent overload of the wire drive.
  - ✘ Do not lay the liner in tight radii.
  - ✘ Check the wire in the liner for ease of movement.

#### Error 4: Excess temperature

Category A

- ✓ The power source is overheating.
  - ✘ Allow the switched-on machine to cool.
- ✓ Fan is blocked, dirty or faulty.
  - ✘ Check the fan and clean or replace.
- ✓ Air inlet or outlet is blocked.
  - ✘ Check the air inlet and outlet.

#### Error 5: Mains overvoltage

Category A <sup>[1]</sup>

- ✓ Mains voltage is too high.
  - ✘ Check the mains voltages and compare them with the connection voltages of the power source.



**Error 6: Mains undervoltage**Category A <sup>[1]</sup>

- ✓ Mains voltage is too low.
  - ✘ Check the mains voltages and compare them with the connection voltages of the power source.

**Error 7: Low coolant level**

Category B

- ✓ Low flow rate.
  - ✘ Fill with coolant.
  - ✘ Check coolant flow - remove kinks in the hose package.
  - ✘ Adjust the flow threshold <sup>[2]</sup>.
  - ✘ Clean the cooler.
- ✓ Pump does not turn.
  - ✘ Turn the pump shaft.
- ✓ Air in the coolant circuit.
  - ✘ Vent the coolant circuit.
- ✓ The hose package is not filled with coolant.
  - ✘ Switch the machine off and on > pump running > filling process.
- ✓ Operation with a gas-cooled welding torch.
  - ✘ Deactivate the torch cooling.
  - ✘ Connect the coolant feed and return with a hose bridge.

**Error 8: Shielding gas error**

Categories A, B

- ✓ No gas.
  - ✘ Check the gas supply.
- ✓ The pre-pressure is too low.
  - ✘ Remove kinks in the hose package (nominal value: 4-6 bar pre-pressure).

**Error 9: Secondary overvoltage**

- ✓ Overvoltage at the output: Inverter error.
  - ✘ Request service.

**Error 10: Earth fault (PE error)**

- ✓ Connection between welding wire and machine casing.
  - ✘ Remove the electrical connection.
- ✓ Connection between welding circuit and machine casing.
  - ✘ Check the connection and routing of the earth wire / welding torch.

**Error 11: Fast shutdown**

Categories A, B

- ✓ Remove the logical signal "Robot ready" during the process.
  - ✘ Eliminate errors in the higher-level control.

## **Error 16: Pilot arc power source - collective error**

Category A

- ✓ The external emergency stop circuit has been interrupted.
  - ✘ Check the emergency stop circuit and eliminate the cause of the error.
- ✓ The emergency stop circuit of the power source has been activated (internally configurable).
  - ✘ Deactivate the emergency stop circuit.
- ✓ The power source is overheating.
  - ✘ Allow the switched-on machine to cool.
- ✓ Fan is blocked, dirty or faulty.
  - ✘ Check the fan and clean or replace.
- ✓ Air inlet or outlet is blocked.
  - ✘ Check the air inlet and outlet.
- ✓ Short circuit on welding torch.
  - ✘ Check the welding torch.
  - ✘ Request service.

## **Error 17: Cold wire error**

Category B

- ✓ Fault in the wire feeder.
  - ✘ Check the electrical connections (connectors, lines).
- ✓ Permanent overload of the wire drive.
  - ✘ Do not lay the liner in tight radii.
  - ✘ Check the liner for ease of movement.

## **Error 18: Plasma gas error**

Category B

- ✓ No gas.
  - ✘ Check the gas supply.
- ✓ The pre-pressure is too low.
  - ✘ Remove kinks in the hose package (nominal value: 4-6 bar pre-pressure).

## **Error 19: Shielding gas error**

Category B

- ✓ No gas.
  - ✘ Check the gas supply.
- ✓ The pre-pressure is too low.
  - ✘ Remove kinks in the hose package (nominal value: 4-6 bar pre-pressure).

**Error 20: Low coolant level**

Category B

- ✓ Low flow rate.
  - ✘ Fill with coolant.
  - ✘ Check coolant flow - remove kinks in the hose package.
  - ✘ Adjust the flow threshold <sup>[2]</sup>.
  - ✘ Clean the cooler.
- ✓ Pump does not turn.
  - ✘ Turn the pump shaft.
- ✓ Air in the coolant circuit.
  - ✘ Vent the coolant circuit.
- ✓ The hose package is not filled with coolant.
  - ✘ Switch the machine off and on > pump running > filling process.
- ✓ Operation with a gas-cooled welding torch.
  - ✘ Deactivate the torch cooling.
  - ✘ Connect the coolant feed and return with a hose bridge.

**Error 22: Excess coolant temperature**

Category B

- ✓ Coolant is overheating <sup>[2]</sup>.
  - ✘ Allow the switched-on machine to cool.
- ✓ Fan is blocked, dirty or faulty.
  - ✘ Check, clean or replace the fan.
- ✓ Air inlet or outlet is blocked.
  - ✘ Check the air inlet and outlet.

**Error 23: Excess temperature**

Category A

- ✓ External component (e.g. HF ignition units) overheated.
- ✓ The power source is overheating.
  - ✘ Allow the switched-on machine to cool.
- ✓ Fan is blocked, dirty or faulty.
  - ✘ Check the fan and clean or replace.
- ✓ Air inlet or outlet is blocked.
  - ✘ Check the air inlet and outlet.

**Error 24: Pilot arc ignition error**

Category B

- ✓ The pilot arc cannot ignite.
  - ✘ Check the welding torch equipment.

**Fault 25: Forming gas error**

Category B

- ✓ No gas.
  - ✘ Check the gas supply.
- ✓ The pre-pressure is too low.
  - ✘ Remove kinks in the hose package (nominal value: 4-6 bar pre-pressure).

## **Error 26: Excess pilot arc module temperature**

Category A

- ✓ The power source is overheating.
  - ✗ Allow the switched-on machine to cool.
- ✓ Fan is blocked, dirty or faulty.
  - ✗ Check the fan and clean or replace.
- ✓ Air inlet or outlet is blocked.
  - ✗ Check the air inlet and outlet.

## **Error 32: Error I>0**

- ✓ Current recording is faulty.
  - ✗ Request service.

## **Error 33: Error UIST**

- ✓ Voltage recording is faulty.
  - ✗ Eliminate the short circuit in the welding circuit.
  - ✗ Remove the external sensor voltage.
  - ✗ Request service.

## **Error 34: Electronics error**

- ✓ A/D channel error
  - ✗ Switch the machine off and on.
  - ✗ Request service.

## **Error 35: Electronics error**

- ✓ Slope error
  - ✗ Switch the machine off and on.
  - ✗ Request service.

## **Error 36: error**

- ✓  conditions violated.
  - ✗ Switch the machine off and on.
  - ✗ Request service.

## **Error 37: Excess temperature / electronics error**

- ✓ The power source is overheating.
  - ✗ Allow the switched-on machine to cool.
- ✓ Fan is blocked, dirty or faulty.
  - ✗ Check the fan and clean or replace.
- ✓ Air inlet or outlet is blocked.
  - ✗ Check the air inlet and outlet.

## **Error 38: Error IIST**

- ✓ Short circuit in the welding circuit before welding.
  - ✗ Eliminate the short circuit in the welding circuit.
  - ✗ Request service.

## **Error 39: Electronics error**

- ✓ Secondary overvoltage
  - ✗ Switch the machine off and on.
  - ✗ Request service.

**Error 40: Electronics error**

- ✓ Error I>0
- ✘ Request service.

**Error 47: Radio link (BT)**

Category B

- ✓ Connection error between welding machine and peripheral unit.
- ✘ Note the documentation for the data interface with radio transmission.

**Error 48: Ignition error**

Category B

- ✓ No ignition at process start (automated machines).
- ✘ Check the wire feeding
- ✘ Check the load cable connections in the welding circuit.
- ✘ Clean corroded surfaces on the workpiece before welding if necessary.

**Error 49: Arc interruption**

Category B

- ✓ An arc interruption occurred during welding with an automated system.
- ✘ Check the wire feeding.
- ✘ Adjust the welding speed.

**Error 50: Program number**

Category B

- ✓ Internal error.
- ✘ Request service.

**Error 51: Emergency stop**

Category A

- ✓ The external emergency stop circuit has been interrupted.
- ✘ Check the emergency stop circuit and eliminate the cause of the error.
- ✓ The emergency stop circuit of the power source has been activated (internally configurable).
- ✘ Deactivate the emergency stop circuit.

**Error 52: No wire feeder**

- ✓ After switching on the automated system, no wire feeder (DV) was detected.
- ✘ Check or connect the control cables of the wire feeders.
- ✘ Check the identification number of the automated wire feeder (for 1DV: number 1, for 2DV: each a wire feeder with number 1 and a wire feeder with number 2).

**Error 53: No wire feeder 2**

Category B

- ✓ Wire feeder 2 was not detected.
- ✘ Check the control cable connections.

**Error 54: VRD error**

- ✓ Error in the open-circuit voltage reduction.
- ✘ If necessary, disconnect the external machine from the welding circuit.
- ✘ Request service.

**Error 55: Excess wire feeder current**

Category B

- ✓ Excess current detected in the wire feed mechanism.
- ✘ Do not lay the liner in tight radii.
- ✘ Check the liner for ease of movement.

## **Error 56: Mains phase failure**

- ✓ One phase of the mains voltage has failed.
- ✘ Check the mains connection, mains plug and mains fuses.

## **Error 57: Slave tachometer error**

Category B

- ✓ Fault in the wire feeder (slave drive).
- ✘ Check the connections (connectors, lines).
- ✓ Permanent overload of the wire drive (slave drive).
- ✘ Do not lay the liner in tight radii.
- ✘ Check the liner for ease of movement.

## **Error 58: Short circuit**

Category B

- ✓ Short circuit in the welding circuit.
- ✘ Eliminate the short circuit in the welding circuit.
- ✘ Place the welding torch on an insulated surface.

## **Error 59: Incompatible machine**

- ✓ A machine connected to the system is not compatible.
- ✘ Disconnect the incompatible machine from the system.

## **Error 60: Incompatible software**

- ✓ The software of a machine is not compatible.
- ✘ Disconnect the incompatible machine from the system
- ✘ Request service.

## **Error 61: Welding monitoring**

- ✓ The actual value of a welding parameter is outside the specified tolerance range.
- ✘ Maintain the tolerance ranges.
- ✘ Adjust the welding parameters.

## **Error 62: System component**

- ✓ The system component was not found.
- ✘ Request service.

## **Error 63: Mains voltage error**

- ✓ Operating and mains voltage are incompatible.
- ✘ Check or adjust the operating and mains voltage.

<sup>[1]</sup> only Picotig 220 pulse

<sup>[2]</sup> See technical data for values and other switching thresholds.

## 7.3 Warnings

Depending on the display options of the machine display, a warning message is displayed as follows:

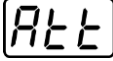
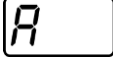
Display type - machine control	Display
Graphic display	
two 7-segment displays	
one 7-segment display	

The cause of the warning is indicated by a corresponding warning number (see table).

- In case of multiple warnings, these are displayed in sequence.
- Document machine warning and inform service personnel, if required.

Warning	Potential cause / remedy
1 Excess temperature	A shutdown is imminent due to excess temperature.
2 Half-wave failures	Check process parameters.
3 Torch cooling warning	Check coolant level and top up if necessary.
4 Shielding gas	Check shielding gas supply.
5 Coolant flow	Check min. flow rate. <sup>[2]</sup>
6 Wire reserve	Only a small amount of wire is left on the spool.
7 CAN bus failure	Wire feeder not connected; automatic circuit-breaker of wire feed motor (reset the tripped automatic circuit-breaker by actuating).
8 Welding circuit	The inductance of the welding circuit is too high for the selected welding task.
9 WF configuration	Check WF configuration.
10 Partial inverter	One of several partial inverters is not supplying welding current.
11 Excess temperature of the coolant <sup>[1]</sup>	Check temperature and switching thresholds. <sup>[2]</sup>
12 Welding monitoring	The actual value of a welding parameter is outside the specified tolerance field.
13 Contact error	The resistance in the welding circuit is too high. Check earth connection.
14 Alignment error	Switch the machine off and on. If the error persists, notify Service.
15 Mains fuse	The power limit of the mains fuse is reached and the welding power is reduced. Check the fuse setting.
16 Shielding gas warning	Check the gas supply.
17 Plasma gas warning	Check the gas supply.
18 Forming gas warning	Check the gas supply.
19 Gas warning 4	reserved
20 Coolant temperature warning	Check coolant level and top up if necessary.
21 Excess temperature 2	reserved
22 Excess temperature 3	reserved
23 Excess temperature 4	reserved

Warning		Potential cause / remedy
24	Coolant flow warning	Check coolant supply. Check coolant level and top up if necessary. Check flow and switching thresholds. <sup>[2]</sup>
25	Flow 2	reserved
26	Flow 3	reserved
27	Flow 4	reserved
28	Wire stock warning	Check wire feeding.
29	Low wire 2	reserved
30	Low wire 3	reserved
31	Low wire 4	reserved
32	Tacho error	Fault of wire feeder - permanent overload of the wire drive.
33	Excess current on the wire feed motor	Excess current detected on wire feed motor.
34	JOB unknown	JOB selection was not carried out because the JOB number is unknown.
35	Excess current on the wire feed motor slave	Excess current detected on wire feed motor slave (push/push system or intermediate drive).
36	Slave tacho error	Fault of wire feeder - permanent overload of the wire drive (push/push system or intermediate drive).
37	FAST bus failure	Wire feeder not connected (reset by actuating the automatic circuit-breaker of the wire feed motor).
38	Incomplete component information	Check the XNET component management.
39	Mains half-wave failure	Check supply voltage.
40	Weak power grid	Check supply voltage.
41	Cooling unit not recognised	Check the cooling unit connection.
47	Battery (remote control, type BT)	Battery level is low (replace battery)

<sup>[1]</sup> only for the XQ machine series

<sup>[2]</sup> See technical data for values and other switching thresholds.



## 7.4 Resetting JOBS (welding tasks) to the factory settings

All customised welding parameters that are stored will be replaced by the factory settings.

### 7.4.1 Resetting a single JOB

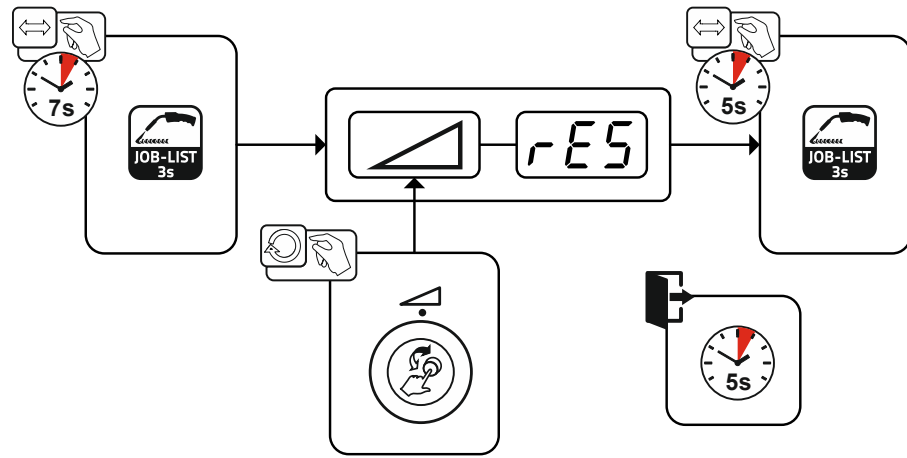

Figure 7-1

### 7.4.2 Resetting all JOBS

JOBs 1–128 and 170–256 will be reset.  
Custom JOBs 129–169 are maintained.

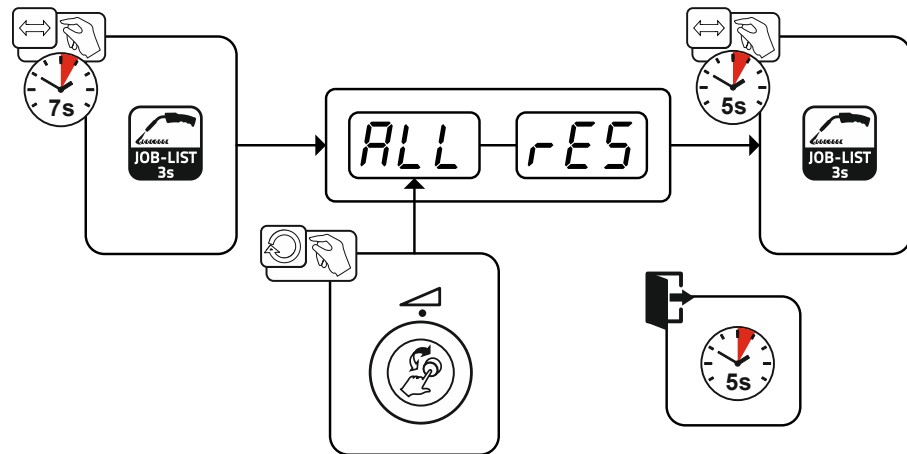

Figure 7-2

## 8 Appendix

### 8.1 JOB-List

JOB no.	Processes	Material	Gas	Diameter [mm]
1	GMAW standard	G3Si1 / G4Si1	100% CO2	0,8
2	GMAW standard	G3Si1 / G4Si1	100% CO2	0,9
3	GMAW standard	G3Si1 / G4Si1	100% CO2	1,0
4	GMAW standard	G3Si1 / G4Si1	100% CO2	1,2
5	GMAW standard	G3Si1 / G4Si1	100% CO2	1,6
6	Standard GMAW / pulse	G3Si1 / G4Si1	Ar-82 / CO2-18 (M21)	0,8
7	Standard GMAW / pulse	G3Si1 / G4Si1	Ar-82 / CO2-18 (M21)	0,9
8	Standard GMAW / pulse	G3Si1 / G4Si1	Ar-82 / CO2-18 (M21)	1,0
9	Standard GMAW / pulse	G3Si1 / G4Si1	Ar-82 / CO2-18 (M21)	1,2
10	Standard GMAW / pulse	G3Si1 / G4Si1	Ar-82 / CO2-18 (M21)	1,6
11	Standard GMAW / pulse	G3Si1 / G4Si1	Ar-90 / CO2-10 (M20)	0,8
12	Standard GMAW / pulse	G3Si1 / G4Si1	Ar-90 / CO2-10 (M20)	0,9
13	Standard GMAW / pulse	G3Si1 / G4Si1	Ar-90 / CO2-10 (M20)	1,0
14	Standard GMAW / pulse	G3Si1 / G4Si1	Ar-90 / CO2-10 (M20)	1,2
15	Standard GMAW / pulse	G3Si1 / G4Si1	Ar-90 / CO2-10 (M20)	1,6
26	Standard GMAW / pulse	CrNi 19 12 3 Nb / 1.4576	Ar-97.5 / CO2-2.5 (M12)	0,8
27	Standard GMAW / pulse	CrNi 19 12 3 Nb / 1.4576	Ar-97.5 / CO2-2.5 (M12)	1,0
28	Standard GMAW / pulse	CrNi 19 12 3 Nb / 1.4576	Ar-97.5 / CO2-2.5 (M12)	1,2
29	Standard GMAW / pulse	CrNi 19 12 3 Nb / 1.4576	Ar-97.5 / CO2-2.5 (M12)	1,6
30	Standard GMAW / pulse	CrNi 18 8 / 1.4370	Ar-97.5 / CO2-2.5 (M12)	0,8
31	Standard GMAW / pulse	CrNi 18 8 / 1.4370	Ar-97.5 / CO2-2.5 (M12)	1,0
32	Standard GMAW / pulse	CrNi 18 8 / 1.4370	Ar-97.5 / CO2-2.5 (M12)	1,2
33	Standard GMAW / pulse	CrNi 18 8 / 1.4370	Ar-97.5 / CO2-2.5 (M12)	1,6
34	Standard GMAW / pulse	CrNi 19 9 / 1.4316	Ar-97.5 / CO2-2.5 (M12)	0,8
35	Standard GMAW / pulse	CrNi 19 9 / 1.4316	Ar-97.5 / CO2-2.5 (M12)	1,0
36	Standard GMAW / pulse	CrNi 19 9 / 1.4316	Ar-97.5 / CO2-2.5 (M12)	1,2
37	Standard GMAW / pulse	CrNi 19 9 / 1.4316	Ar-97.5 / CO2-2.5 (M12)	1,6
38	Standard GMAW / pulse	CrNi 19 12 3 / 1.4430	Ar-97.5 / CO2-2.5 (M12)	0,8
39	Standard GMAW / pulse	CrNi 19 12 3 / 1.4430	Ar-97.5 / CO2-2.5 (M12)	1,0
40	Standard GMAW / pulse	CrNi 19 12 3 / 1.4430	Ar-97.5 / CO2-2.5 (M12)	1,2
41	Standard GMAW / pulse	CrNi 19 12 3 / 1.4430	Ar-97.5 / CO2-2.5 (M12)	1,6
42	Standard GMAW / pulse	CrNi 22 9 3 / 1.4462	Ar-97.5 / CO2-2.5 (M12)	0,8
43	Standard GMAW / pulse	CrNi 22 9 3 / 1.4462	Ar-97.5 / CO2-2.5 (M12)	1,0
44	Standard GMAW / pulse	CrNi 22 9 3 / 1.4462	Ar-97.5 / CO2-2.5 (M12)	1,2
45	Standard GMAW / pulse	CrNi 22 9 3 / 1.4462	Ar-97.5 / CO2-2.5 (M12)	1,6
46	Standard GMAW / pulse	CrNi 22 9 3 / 1.4462	Ar-78 / He-20 / CO2-2 (M12)	0,8
47	Standard GMAW / pulse	CrNi 22 9 3 / 1.4462	Ar-78 / He-20 / CO2-2 (M12)	1,0
48	Standard GMAW / pulse	CrNi 22 9 3 / 1.4462	Ar-78 / He-20 / CO2-2 (M12)	1,2

JOB no.	Processes	Material	Gas	Diameter [mm]
49	Standard GMAW / pulse	CrNi 22 9 3 / 1.4462	Ar-78 / He-20 / CO2-2 (M12)	1,6
50	coldArc / coldArc puls	CrNi 19 9 / 1.4316	Ar-97.5 / CO2-2.5 (M12)	0,8
51	coldArc / coldArc puls	CrNi 19 9 / 1.4316	Ar-97.5 / CO2-2.5 (M12)	1,0
52	coldArc / coldArc puls	CrNi 19 9 / 1.4316	Ar-97.5 / CO2-2.5 (M12)	1,2
55	coldArc / coldArc puls	AlMg4.5Mn	Ar-100 (I1)	1,0
56	coldArc / coldArc puls	AlMg4.5Mn	Ar-100 (I1)	1,2
59	coldArc / coldArc puls	AlSi	Ar-100 (I1)	1,0
60	coldArc / coldArc puls	AlSi	Ar-100 (I1)	1,2
63	coldArc / coldArc puls	Al99	Ar-100 (I1)	1,0
64	coldArc / coldArc puls	Al99	Ar-100 (I1)	1,2
66	coldArc Brazing	CuSi	Ar-100 (I1)	0,8
67	coldArc Brazing	CuSi	Ar-100 (I1)	1,0
68	coldArc Brazing	CuSi	Ar-100 (I1)	1,2
70	coldArc Brazing	CuAl	Ar-100 (I1)	0,8
71	coldArc Brazing	CuAl	Ar-100 (I1)	1,0
72	coldArc Brazing	CuAl	Ar-100 (I1)	1,2
74	Standard GMAW / pulse	AlMg4.5Mn	Ar-100 (I1)	0,8
75	Standard GMAW / pulse	AlMg4.5Mn	Ar-100 (I1)	1,0
76	Standard GMAW / pulse	AlMg4.5Mn	Ar-100 (I1)	1,2
77	Standard GMAW / pulse	AlMg4.5Mn	Ar-100 (I1)	1,6
78	Standard GMAW / pulse	AlMg4.5Mn	Ar-70 / He-30 (I3)	0,8
79	Standard GMAW / pulse	AlMg4.5Mn	Ar-70 / He-30 (I3)	1,0
80	Standard GMAW / pulse	AlMg4.5Mn	Ar-70 / He-30 (I3)	1,2
81	Standard GMAW / pulse	AlMg4.5Mn	Ar-70 / He-30 (I3)	1,6
82	Standard GMAW / pulse	AlSi	Ar-100 (I1)	0,8
83	Standard GMAW / pulse	AlSi	Ar-100 (I1)	1,0
84	Standard GMAW / pulse	AlSi	Ar-100 (I1)	1,2
85	Standard GMAW / pulse	AlSi	Ar-100 (I1)	1,6
86	Standard GMAW / pulse	AlSi	Ar-70 / He-30 (I3)	0,8
87	Standard GMAW / pulse	AlSi	Ar-70 / He-30 (I3)	1,0
88	Standard GMAW / pulse	AlSi	Ar-70 / He-30 (I3)	1,2
89	Standard GMAW / pulse	AlSi	Ar-70 / He-30 (I3)	1,6
90	Standard GMAW / pulse	Al99	Ar-100 (I1)	0,8
91	Standard GMAW / pulse	Al99	Ar-100 (I1)	1,0
92	Standard GMAW / pulse	Al99	Ar-100 (I1)	1,2
93	Standard GMAW / pulse	Al99	Ar-100 (I1)	1,6
94	Standard GMAW / pulse	Al99	Ar-70 / He-30 (I3)	0,8
95	Standard GMAW / pulse	Al99	Ar-70 / He-30 (I3)	1,0
96	Standard GMAW / pulse	Al99	Ar-70 / He-30 (I3)	1,2
97	Standard GMAW / pulse	Al99	Ar-70 / He-30 (I3)	1,6
98	Standard GMAW / pulse	CuSi	Ar-100 (I1)	0,8
99	Standard GMAW / pulse	CuSi	Ar-100 (I1)	1,0
100	Standard GMAW / pulse	CuSi	Ar-100 (I1)	1,2
101	Standard GMAW / pulse	CuSi	Ar-100 (I1)	1,6
102	Standard GMAW / pulse	CuSi	Ar-97.5 / CO2-2.5 (M12)	0,8
103	Standard GMAW / pulse	CuSi	Ar-97.5 / CO2-2.5 (M12)	1,0

JOB no.	Processes	Material	Gas	Diameter [mm]
104	Standard GMAW / pulse	CuSi	Ar-97.5 / CO2-2.5 (M12)	1,2
105	Standard GMAW / pulse	CuSi	Ar-97.5 / CO2-2.5 (M12)	1,6
106	Standard GMAW / pulse	CuAl	Ar-100 (I1)	0,8
107	Standard GMAW / pulse	CuAl	Ar-100 (I1)	1,0
108	Standard GMAW / pulse	CuAl	Ar-100 (I1)	1,2
109	Standard GMAW / pulse	CuAl	Ar-100 (I1)	1,6
110	Brazing	CuSi	Ar-97.5 / CO2-2.5 (M12)	0,8
111	Brazing	CuSi	Ar-97.5 / CO2-2.5 (M12)	1,0
112	Brazing	CuSi	Ar-97.5 / CO2-2.5 (M12)	1,2
113	Brazing	CuSi	Ar-97.5 / CO2-2.5 (M12)	1,6
114	Brazing	CuSi	Ar-100 (I1)	0,8
115	Brazing	CuSi	Ar-100 (I1)	1,0
116	Brazing	CuSi	Ar-100 (I1)	1,2
117	Brazing	CuSi	Ar-100 (I1)	1,6
118	Brazing	CuAl	Ar-97.5 / CO2-2.5 (M12)	0,8
119	Brazing	CuAl	Ar-97.5 / CO2-2.5 (M12)	1,0
120	Brazing	CuAl	Ar-97.5 / CO2-2.5 (M12)	1,2
121	Brazing	CuAl	Ar-97.5 / CO2-2.5 (M12)	1,6
122	Brazing	CuAl	Ar-100 (I1)	0,8
123	Brazing	CuAl	Ar-100 (I1)	1,0
124	Brazing	CuAl	Ar-100 (I1)	1,2
125	Brazing	CuAl	Ar-100 (I1)	1,6
126	Gouging			
127	TIG (lift arc)			
128	MMA			
129	Special JOB 1	Special	Special	Spezial
130	Special JOB 2	Special	Special	Spezial
131	Special JOB 3	Special	Special	Spezial
132		Free JOB		
133		Free JOB		
134		Free JOB		
135		Free JOB		
136		Free JOB		
137		Free JOB		
138		Free JOB		
139		Free JOB		
140		Block 1/ JOB1		
141		Block 1/ JOB2		
142		Block 1/ JOB3		
143		Block 1/ JOB4		
144		Block 1/ JOB5		
145		Block 1/ JOB6		
146		Block 1/ JOB7		
147		Block 1/ JOB8		
148		Block 1/ JOB9		
149		Block 1/ JOB10		
150		Block 2/ JOB1		

JOB no.	Processes	Material	Gas	Diameter [mm]
151		Block 2/ JOB2		
152		Block 2/ JOB3		
153		Block 2/ JOB4		
154		Block 2/ JOB5		
155		Block 2/ JOB6		
156		Block 2/ JOB7		
157		Block 2/ JOB8		
158		Block 2/ JOB9		
159		Block 2/ JOB10		
160		Block 3/ JOB1		
161		Block 3/ JOB2		
162		Block 3/ JOB3		
163		Block 3/ JOB4		
164		Block 3/ JOB5		
165		Block 3/ JOB6		
166		Block 3/ JOB7		
167		Block 3/ JOB8		
168		Block 3/ JOB9		
169		Block 3/ JOB10		
171	coldArc / coldArc puls	G3Si1 / G4Si1	Ar-90 / CO2-10 (M20)	1,0
172	coldArc / coldArc puls	G3Si1 / G4Si1	Ar-90 / CO2-10 (M20)	1,2
173	rootArc / rootArc puls	G3Si1 / G4Si1	Ar-90 / CO2-10 (M20)	1,0
174	rootArc / rootArc puls	G3Si1 / G4Si1	Ar-90 / CO2-10 (M20)	1,2
179	forceArc / forceArc puls	G3Si1 / G4Si1	Ar-82 / CO2-18 (M21)	1,0
180	forceArc / forceArc puls	G3Si1 / G4Si1	Ar-82 / CO2-18 (M21)	1,2
181	forceArc / forceArc puls	G3Si1 / G4Si1	Ar-82 / CO2-18 (M21)	1,6
182	coldArc	G3Si1 / G4Si1	CO2-100 (C1)	0,8
183	coldArc	G3Si1 / G4Si1	CO2-100 (C1)	0,9
184	coldArc	G3Si1 / G4Si1	CO2-100 (C1)	1,0
185	coldArc	G3Si1 / G4Si1	CO2-100 (C1)	1,2
188	GMAW Non-synergic	Special	Special	Spezial
189	forceArc / forceArc puls	G3Si1 / G4Si1	Ar-82 / CO2-18 (M21)	0,8
190	forceArc / forceArc puls	G3Si1 / G4Si1	Ar-90 / CO2-10 (M20)	0,8
191	coldArc / coldArc puls	G3Si1 / G4Si1	Ar-82 / CO2-18 (M21)	0,8
192	coldArc / coldArc puls	G3Si1 / G4Si1	Ar-82 / CO2-18 (M21)	0,9
193	coldArc / coldArc puls	G3Si1 / G4Si1	Ar-82 / CO2-18 (M21)	1,0
194	coldArc / coldArc puls	G3Si1 / G4Si1	Ar-82 / CO2-18 (M21)	1,2
195	coldArc / coldArc puls	G3Si1 / G4Si1	Ar-82 / CO2-18 (M21)	1,6
197	coldArc Brazing	AlSi	Ar-100 (I1)	1,0
198	coldArc Brazing	AlSi	Ar-100 (I1)	1,2
201	coldArc Brazing	ZnAl	Ar-100 (I1)	1,0
202	coldArc Brazing	ZnAl	Ar-100 (I1)	1,2
204	rootArc	G3Si1 / G4Si1	CO2-100 (C1)	1,0
205	rootArc	G3Si1 / G4Si1	CO2-100 (C1)	1,2
206	rootArc / rootArc puls	G3Si1 / G4Si1	Ar-82 / CO2-18 (M21)	1,0
207	rootArc / rootArc puls	G3Si1 / G4Si1	Ar-82 / CO2-18 (M21)	1,2
208	coldArc - Mg/Mg	Mg	Ar-70 / He-30 (I3)	1,2

JOB no.	Processes	Material	Gas	Diameter [mm]
209	coldArc - Mg/Mg	Mg	Ar-70 / He-30 (I3)	1,6
212	Flux cored wire rutile	FCW CrNi Rutile	CO2-100 (C1)	1,2
213	Flux cored wire rutile	FCW CrNi Rutile	CO2-100 (C1)	1,6
216	Standard GMAW / pulse	AlMg3	Ar-100 (I1)	1,0
217	Standard GMAW / pulse	AlMg3	Ar-100 (I1)	1,2
218	Standard GMAW / pulse	AlMg3	Ar-100 (I1)	1,6
220	coldArc - St/Al	ZnAl	Ar-100 (I1)	1,0
221	coldArc - St/Al	ZnAl	Ar-100 (I1)	1,2
224	coldArc - St/Al	AlSi	Ar-100 (I1)	1,0
225	coldArc - St/Al	AlSi	Ar-100 (I1)	1,2
229	Flux cored wire metal	FCW CrNi Metal	Ar-97.5 / CO2-2.5 (M12)	1,2
230	Flux cored wire metal	FCW CrNi Metal	Ar-97.5 / CO2-2.5 (M12)	1,6
233	Flux cored wire rutile	FCW CrNi Rutile	Ar-82 / CO2-18 (M21)	1,2
234	Flux cored wire rutile	FCW CrNi Rutile	Ar-82 / CO2-18 (M21)	1,6
235	Flux cored wire metal	FCW Steel Metal	Ar-82 / CO2-18 (M21)	0,8
237	Flux cored wire metal	FCW Steel Metal	Ar-82 / CO2-18 (M21)	1,0
238	Flux cored wire metal	FCW Steel Metal	Ar-82 / CO2-18 (M21)	1,2
239	Flux cored wire metal	FCW Steel Metal	Ar-82 / CO2-18 (M21)	1,6
240	Flux cored wire rutile	FCW Steel Rutile	Ar-82 / CO2-18 (M21)	0,8
242	Flux cored wire rutile	FCW Steel Rutile	Ar-82 / CO2-18 (M21)	1,0
243	Flux cored wire rutile	FCW Steel Rutile	Ar-82 / CO2-18 (M21)	1,2
244	Flux cored wire rutile	FCW Steel Rutile	Ar-82 / CO2-18 (M21)	1,6
245	forceArc / forceArc puls	Al99	Ar-100 (I1)	1,2
246	forceArc / forceArc puls	Al99	Ar-100 (I1)	1,6
247	forceArc / forceArc puls	AlMg4.5Mn	Ar-100 (I1)	1,2
248	forceArc / forceArc puls	AlMg4.5Mn	Ar-100 (I1)	1,6
249	forceArc / forceArc puls	AlSi	Ar-100 (I1)	1,2
250	forceArc / forceArc puls	AlSi	Ar-100 (I1)	1,6
251	forceArc / forceArc puls	CrNi 19 9 / 1.4316	Ar-97.5 / CO2-2.5 (M12)	1,0
252	forceArc / forceArc puls	CrNi 19 9 / 1.4316	Ar-97.5 / CO2-2.5 (M12)	1,2
253	forceArc / forceArc puls	CrNi 19 9 / 1.4316	Ar-97.5 / CO2-2.5 (M12)	1,6
254	forceArc / forceArc puls	G3Si1 / G4Si1	Ar-90 / CO2-10 (M20)	1,0
255	forceArc / forceArc puls	G3Si1 / G4Si1	Ar-90 / CO2-10 (M20)	1,2
256	forceArc / forceArc puls	G3Si1 / G4Si1	Ar-90 / CO2-10 (M20)	1,6
258	Standard GMAW / pulse	AlMg4.5Mn	Ar-50/He-50 (I3)	1,2
259	Standard GMAW / pulse	AlMg4.5Mn	Ar-50/He-50 (I3)	1,6
260	Flux cored wire rutile	FCW Steel Rutile	CO2-100 (C1)	1,2
261	Flux cored wire rutile	FCW Steel Rutile	CO2-100 (C1)	1,6
263	Flux cored wire metal	High-strength steels / Special	Ar-82 / CO2-18 (M21)	1,2
264	Flux cored wire basic	FCW Steel Basic	Ar-82 / CO2-18 (M21)	1,2
268	Surfacing	NiCr 6617 / 2.4627	Ar-70 / He-30 (I3)	1,2
269	Surfacing	NiCr 6617 / 2.4627	Ar-70 / He-30 (I3)	1,6
271	Surfacing	NiCr 6625 / 2.4831	Ar-70 / He-30 (I3)	1,0
272	Surfacing	NiCr 6625 / 2.4831	Ar-70 / He-30 (I3)	1,2
273	Surfacing	NiCr 6625 / 2.4831	Ar-70 / He-30 (I3)	1,6
275	Surfacing	NiCr 6625 / 2.4831	Ar-78 / He-20 / CO2-2 (M12)	1,0



JOB no.	Processes	Material	Gas	Diameter [mm]
276	Surfacing	NiCr 6625 / 2.4831	Ar-78 / He-20 / CO2-2 (M12)	1,2
277	Surfacing	NiCr 6625 / 2.4831	Ar-78 / He-20 / CO2-2 (M12)	1,6
279	Standard GMAW / pulse	CrNi 25 20 / 1.4842	Ar-97.5 / CO2-2.5 (M12)	1,0
280	Standard GMAW / pulse	CrNi 25 20 / 1.4842	Ar-97.5 / CO2-2.5 (M12)	1,2
282	Standard GMAW / pulse	CrNi 23 12 / 1.4332	Ar-97.5 / CO2-2.5 (M12)	0,8
283	Standard GMAW / pulse	CrNi 23 12 / 1.4332	Ar-97.5 / CO2-2.5 (M12)	1,0
284	Standard GMAW / pulse	CrNi 23 12 / 1.4332	Ar-97.5 / CO2-2.5 (M12)	1,2
285	Standard GMAW / pulse	CrNi 23 12 / 1.4332	Ar-97.5 / CO2-2.5 (M12)	1,6
290	forceArc / forceArc puls Flux cored wire metal	FCW Steel Metal	Ar-82 / CO2-18 (M21)	0,8
291	forceArc / forceArc puls Flux cored wire metal	FCW Steel Metal	Ar-82 / CO2-18 (M21)	1,0
292	forceArc / forceArc puls Flux cored wire metal	FCW Steel Metal	Ar-82 / CO2-18 (M21)	1,2
293	forceArc / forceArc puls Flux cored wire metal	FCW Steel Metal	Ar-82 / CO2-18 (M21)	1,6
303	forceArc / forceArc puls	CrNi 19 12 3 Nb / 1.4576	Ar-97.5 / CO2-2.5 (M12)	1,0
304	forceArc / forceArc puls	CrNi 19 12 3 Nb / 1.4576	Ar-97.5 / CO2-2.5 (M12)	1,2
305	forceArc / forceArc puls	CrNi 19 12 3 Nb / 1.4576	Ar-97.5 / CO2-2.5 (M12)	1,6
307	forceArc / forceArc puls	CrNi 18 8 / 1.4370	Ar-97.5 / CO2-2.5 (M12)	1,0
308	forceArc / forceArc puls	CrNi 18 8 / 1.4370	Ar-97.5 / CO2-2.5 (M12)	1,2
309	forceArc / forceArc puls	CrNi 18 8 / 1.4370	Ar-97.5 / CO2-2.5 (M12)	1,6
311	forceArc / forceArc puls	CrNi 19 12 3 / 1.4430	Ar-97.5 / CO2-2.5 (M12)	1,0
312	forceArc / forceArc puls	CrNi 19 12 3 / 1.4430	Ar-97.5 / CO2-2.5 (M12)	1,2
313	forceArc / forceArc puls	CrNi 19 12 3 / 1.4430	Ar-97.5 / CO2-2.5 (M12)	1,6
315	forceArc / forceArc puls	CrNi 22 9 3 / 1.4462	Ar-97.5 / CO2-2.5 (M12)	1,0
316	forceArc / forceArc puls	CrNi 22 9 3 / 1.4462	Ar-97.5 / CO2-2.5 (M12)	1,2
317	forceArc / forceArc puls	CrNi 22 9 3 / 1.4462	Ar-97.5 / CO2-2.5 (M12)	1,6
319	forceArc / forceArc puls	CrNi 25 20 / 1.4842	Ar-97.5 / CO2-2.5 (M12)	1,0
320	forceArc / forceArc puls	CrNi 25 20 / 1.4842	Ar-97.5 / CO2-2.5 (M12)	1,2
323	forceArc / forceArc puls	CrNi 23 12 / 1.4332	Ar-97.5 / CO2-2.5 (M12)	1,0
324	forceArc / forceArc puls	CrNi 23 12 / 1.4332	Ar-97.5 / CO2-2.5 (M12)	1,2
325	forceArc / forceArc puls	CrNi 23 12 / 1.4332	Ar-97.5 / CO2-2.5 (M12)	1,6
326	coldArc / coldArc puls	CrNi 19 12 3 Nb / 1.4576	Ar-97.5 / CO2-2.5 (M12)	0,8
327	coldArc / coldArc puls	CrNi 19 12 3 Nb / 1.4576	Ar-97.5 / CO2-2.5 (M12)	1,0
328	coldArc / coldArc puls	CrNi 19 12 3 Nb / 1.4576	Ar-97.5 / CO2-2.5 (M12)	1,2
330	coldArc / coldArc puls	CrNi 18 8 / 1.4370	Ar-97.5 / CO2-2.5 (M12)	0,8
331	coldArc / coldArc puls	CrNi 18 8 / 1.4370	Ar-97.5 / CO2-2.5 (M12)	1,0
332	coldArc / coldArc puls	CrNi 18 8 / 1.4370	Ar-97.5 / CO2-2.5 (M12)	1,2
334	coldArc / coldArc puls	CrNi 19 12 3 / 1.4430	Ar-97.5 / CO2-2.5 (M12)	0,8
335	coldArc / coldArc puls	CrNi 19 12 3 / 1.4430	Ar-97.5 / CO2-2.5 (M12)	1,0

JOB no.	Processes	Material	Gas	Diameter [mm]
336	coldArc / coldArc puls	CrNi 19 12 3 / 1.4430	Ar-97.5 / CO2-2.5 (M12)	1,2
338	coldArc / coldArc puls	CrNi 22 9 3/1.4462/Duplex	Ar-97.5 / CO2-2.5 (M12)	0,8
339	coldArc / coldArc puls	CrNi 22 9 3/1.4462/Duplex	Ar-97.5 / CO2-2.5 (M12)	1,0
340	coldArc / coldArc puls	CrNi 22 9 3/1.4462/Duplex	Ar-97.5 / CO2-2.5 (M12)	1,2
350	Self-shielded flux cored wire	FCW Steel Rutile	No Gas	0,9
351	Self-shielded flux cored wire	FCW Steel Rutile	No Gas	1,0
352	Self-shielded flux cored wire	FCW Steel Rutile	No Gas	1,2
359	wiredArc / wiredArc puls	G3Si1 / G4Si1	Ar-82 / CO2-18 (M21)	1,0
360	wiredArc / wiredArc puls	G3Si1 / G4Si1	Ar-82 / CO2-18 (M21)	1,2
367	wiredArc / wiredArc puls	CrNi 19 9 / 1.4316	Ar-97.5 / CO2-2.5 (M12)	1,0
368	wiredArc / wiredArc puls	CrNi 19 9 / 1.4316	Ar-97.5 / CO2-2.5 (M12)	1,2
371	wiredArc / wiredArc puls	CrNi 19 12 3 / 1.4430	Ar-97.5 / CO2-2.5 (M12)	1,0
384	wiredArc / wiredArc puls	AlMg4.5Mn	Ar-50/He-50 (I3)	1,2
385	wiredArc / wiredArc puls	AlMg4.5Mn	Ar-50/He-50 (I3)	1,6
386	Surfacing	Co-based	Ar-100 (I1)	1,2
387	Surfacing	Co-based	Ar-100 (I1)	1,6
388	Surfacing	CrNi 23 12 / 1.4332	Ar-97.5 / CO2-2.5 (M12)	1,2
389	Surfacing	CrNi 23 12 / 1.4332	Ar-97.5 / CO2-2.5 (M12)	1,6
391	acArc puls <sup>[1]</sup>	AlMg4.5Mn	Ar-100 (I1)	1,0
392	acArc puls <sup>[1]</sup>	AlMg4.5Mn	Ar-100 (I1)	1,2
393	acArc puls <sup>[1]</sup>	AlMg4.5Mn	Ar-100 (I1)	1,6
394	acArc puls <sup>[1]</sup>	AlSi	Ar-residue/O2-0.03	1,0
395	acArc puls <sup>[1]</sup>	AlSi	Ar-residue/O2-0.03	1,2

<sup>[1]</sup> active only in machine series Titan XQ AC.



## 8.2 Parameter overview – setting ranges

### 8.2.1 MIG/MAG welding

Name	Display			Setting range	
	Code	Standard (ex works)	Unit	Min.	Max.
Gas pre-flow time "t1"	$\overline{GPr}$	0,1	s	0	- 20
Wire feed speed, relative (start program Start)		55	%	1	- 200
Voltage correction		0	V	-9,9	9,9
Start time "t2"		0,1	s	0,00	- 20,0
Slope time "t3" (time from start program Start to main program P <sub>A</sub> )		0,3	s	0,00	- 20,0
Wire feed speed, absolute (main program P <sub>A</sub> )		-	m/min	0,00	- 20,0
Pulse time "t4"		0,01	s	0,00	- 20,0
Wire feed speed, relative (down-slope program P <sub>B</sub> )		60	%	1	- 200
Pulse pause time "t5"		0,01	s	0,00	- 20,0
Slope time "t6" (time from main program P <sub>A</sub> to end program End)		0,0	s	0,00	- 20,0
Wire feed speed, relative (end program End)		100	%	1	- 200
Duration of end program "t7"		0,0	s	0,00	- 20,0
Gas post-flow time "t8"	$\overline{GPE}$	0,0	s	0,0	- 20,0
Gas nominal value (option GFE)		8,5	l/min	3,0	30,0

## 8.2.2 TIG welding

Name	Display			Setting range	
	Code	Standard (ex works)	Unit	Min.	Max.
Gas pre-flow time "t1"	ⓄPⓇ	0,2	s	0	20
Start current "t2" (percentage of main current "t4")		20	%	1	200
Start time "t2"		0,5	s	0,0	20,0
Slope time "t3"		0,3	s	0,0	20,0
Main current "t4" (depending on power source)			A	-	
Pulse current "t4"		140	%	1	200
Pulse time "t4"		0,01	s	0,00	20,0
Spot time "t4"		0,1	s	0,01	20,0
Secondary current "t5" (percentage of main current)		40	%	1	200
Pulse pause current "t5"		0,3	s	0,01	20,0
Pulse pause time "t5"		0,3	s	0,00	20,0
Slope time "t6" (time from main current to end current )		0,3	s	0,00	20,0
End current "t7" (percentage of main current)		70	%	1	200
End current time "t7"		0,5	s	0,01	20,0
Gas post-flow time "t8"	ⓄPⓁ	0,5	s	0,0	20,0

## 8.2.3 MMA welding

Name	Display			Setting range	
	Code	Standard (ex works)	Unit	Min.	Max.
Main current AMP, depending on power source		-	A	-	-
Hot start current, percentage of AMP		120	%	1	200
Hot start current, absolute, depending on power source		-	A	-	-
Hot start time		0,5	s	0,0	10,0
Arcforce	ⓇⓇⓇ	0		-40	40

## 8.3 Searching for a dealer

Sales & service partners  
[www.ewm-group.com/en/specialist-dealers](http://www.ewm-group.com/en/specialist-dealers)



"More than 400 EWM sales partners worldwide"