



EN

Power source

Taurus XQ 350 Synergic C
Taurus XQ 400 Synergic C

099-005653-EW501

Observe additional system documents!

26.10.2022

**Register now
and benefit!**
**Jetzt Registrieren
und Profitieren!**

www.ewm-group.com



General instructions

WARNING



Read the operating instructions!

The operating instructions provide an introduction to the safe use of the products.

- Read and observe the operating instructions for all system components, especially the safety instructions and warning notices!
- Observe the accident prevention regulations and any regional regulations!
- The operating instructions must be kept at the location where the machine is operated.
- Safety and warning labels on the machine indicate any possible risks. Keep these labels clean and legible at all times.
- The machine has been constructed to state-of-the-art standards in line with any applicable regulations and industrial standards. Only trained personnel may operate, service and repair the machine.
- Technical changes due to further development in machine technology may lead to a differing welding behaviour.

In the event of queries on installation, commissioning, operation or special conditions at the installation site, or on usage, please contact your sales partner or our customer service department on +49 2680 181-0.

A list of authorised sales partners can be found at www.ewm-group.com/en/specialist-dealers.

Liability relating to the operation of this equipment is restricted solely to the function of the equipment. No other form of liability, regardless of type, shall be accepted. This exclusion of liability shall be deemed accepted by the user on commissioning the equipment.

The manufacturer is unable to monitor whether or not these instructions or the conditions and methods are observed during installation, operation, usage and maintenance of the equipment.

An incorrectly performed installation can result in material damage and injure persons as a result. For this reason, we do not accept any responsibility or liability for losses, damages or costs arising from incorrect installation, improper operation or incorrect usage and maintenance or any actions connected to this in any way.

© EWM AG

Dr. Günter-Henle-Strasse 8

56271 Mündersbach Germany

Tel.: +49 2680 181-0, Fax: -244

Email: info@ewm-group.com

www.ewm-group.com

The copyright to this document remains the property of the manufacturer.

Copying, including extracts, only permitted with written approval.

The content of this document has been prepared and reviewed with all reasonable care. The information provided is subject to change; errors excepted.

Data security

The user is responsible for backing up data of all changes from the factory setting. The user is liable for erased personal settings. The manufacturer does not assume any liability for this.

1 Contents

1	Contents	3
2	For your safety	6
2.1	Notes on using these operating instructions.....	6
2.2	Explanation of icons.....	7
2.3	Safety instructions.....	8
2.4	Transport and installation	11
3	Intended use	13
3.1	Applications.....	13
3.2	Documents which also apply	13
3.2.1	Warranty	13
3.2.2	Declaration of Conformity.....	13
3.2.3	Welding in environments with increased electrical hazards.....	14
3.2.4	Service documents (spare parts and circuit diagrams).....	14
3.2.5	Calibration/Validation	14
3.2.6	Part of the complete documentation.....	14
4	Machine description – quick overview	15
4.1	Machine configuration.....	15
4.2	Front view / side view from the right	16
4.3	Rear view / side view from left	18
4.4	Inside view	20
5	Design and function	21
5.1	Transport and installation	21
5.1.1	Lifting by crane	21
5.1.1.1	Craning principle	21
5.1.2	Ambient conditions	22
5.1.3	Machine cooling.....	22
5.1.4	Workpiece lead, general.....	22
5.1.5	Welding torch cooling system.....	23
5.1.5.1	Functional characteristics	23
5.1.5.2	Permitted torch coolant	23
5.1.5.3	Maximal hose package length	23
5.1.5.4	Adding coolant	24
5.1.6	Notes on the installation of welding current leads.....	25
5.1.7	Stray welding currents.....	26
5.1.8	Mains connection.....	26
5.1.8.1	Visual inspection of the set mains voltage.....	27
5.1.8.2	Adjusting the power source to the mains voltage	28
5.1.8.3	Re-commissioning.....	28
5.1.8.4	Mains configuration.....	29
5.1.9	Switching on and system diagnosis	29
5.1.10	Shielding gas supply (shielding gas cylinder for welding machine)	30
5.1.10.1	Pressure regulator connection	30
5.1.10.2	Shielding gas hose connection	31
5.1.10.3	Setting the shielding gas volume (gas test)/rinse hose package.....	31
5.1.11	LED status bar - display of operating status	32
5.1.12	Protective flap, welding machine control.....	32
5.1.13	Polarity selection plug - changing the welding current polarity	33
5.2	MIG/MAG welding.....	33
5.2.1	Assemble the wire guide	33
5.2.2	Welding torch connection.....	34
5.2.3	Connection for workpiece lead	35
5.2.4	Wire feed	36
5.2.4.1	Inserting the wire spool	36
5.2.4.2	Changing the wire feed rollers	37
5.2.4.3	Inching the wire electrode	40
5.2.4.4	Spool brake setting	41
5.2.5	Welding task selection.....	41
5.3	TIG welding.....	42

5.3.1	Welding torch connection	42
5.3.2	Connection for workpiece lead	43
5.3.3	Welding task selection	43
5.4	MMA welding.....	43
5.4.1	Connecting the electrode holder and workpiece lead	43
5.4.2	Welding task selection	44
5.5	Remote control.....	44
5.6	Access control.....	44
5.7	Interfaces for automation	44
5.7.1	Automation interface.....	44
5.7.2	RINT X12 robot interface.....	45
5.7.3	BUSINT X11 industrial bus interface	45
5.8	PC interface	45
5.8.1	Connection.....	46
5.9	Component identification.....	46
5.10	Network connection.....	46
6	Maintenance, care and disposal	47
6.1	General.....	47
6.2	Explanation of icons	48
6.3	Maintenance schedule	48
6.3.1	Dirt filter.....	50
6.3.2	Coolant error.....	51
6.3.3	Heat exchanger (torch cooling)	53
6.3.4	Power source (inverter)	54
6.3.5	Annual test (inspection and testing during operation)	54
6.4	Disposing of equipment.....	55
7	Rectifying faults.....	56
7.1	Error messages (power source).....	56
7.2	Warnings	62
7.3	Checklist for rectifying faults	64
7.4	Vent coolant circuit.....	66
7.5	Fixing the pump shaft (coolant circuit)	67
8	Technical data.....	68
8.1	Dimensions and weighte	68
8.2	Welding torch cooling system	68
8.3	Performance data.....	69
8.3.1	Taurus XQ 350 Synergic C.....	69
8.3.2	Taurus XQ 400 Synergic C.....	70
9	Accessories	71
9.1	General accessories	71
9.2	Welding torch cooling system	71
9.2.1	Coolant - type blueCool.....	71
9.2.2	Coolant - type KF.....	71
9.3	7-pole remote control	71
9.3.1	Extension cable	71
9.4	19-pole remote control	72
9.4.1	Connection cables	72
9.4.2	Extension cable	72
9.5	Options.....	72
9.6	Computer communication	72
9.7	Component identification.....	72
10	Replaceable parts.....	73
10.1	Wire feed rollers	73
10.1.1	Wire feed rollers for steel wire	73
10.1.2	Wire feed rollers for aluminium wire	73
10.1.3	Wire feed rollers for cored wire.....	74
10.1.4	Wire guide.....	74
11	Appendix	75
11.1	Searching for a dealer.....	75

2 For your safety

2.1 Notes on using these operating instructions

DANGER

Working or operating procedures which must be closely observed to prevent imminent serious and even fatal injuries.

- Safety notes include the "DANGER" keyword in the heading with a general warning symbol.
- The hazard is also highlighted using a symbol on the edge of the page.

WARNING

Working or operating procedures which must be closely observed to prevent serious and even fatal injuries.

- Safety notes include the "WARNING" keyword in the heading with a general warning symbol.
- The hazard is also highlighted using a symbol in the page margin.

CAUTION

Working or operating procedures which must be closely observed to prevent possible minor personal injury.

- The safety information includes the "CAUTION" keyword in its heading with a general warning symbol.
- The risk is explained using a symbol on the edge of the page.



Technical aspects which the user must observe to avoid material or equipment damage.

Instructions and lists detailing step-by-step actions for given situations can be recognised via bullet points, e.g.:

- Insert the welding current lead socket into the relevant socket and lock.

2.2 Explanation of icons

Symbol	Description	Symbol	Description
	Indicates technical aspects which the user must observe.		Activate and release / Tap / Tip
	Switch off machine		Release
	Switch on machine		Press and hold
	Incorrect / Invalid		Switch
	Correct / Valid		Turn
	Input		Numerical value – adjustable
	Navigation		Signal light lights up in green
	Output		Signal light flashes green
	Time representation (e.g.: wait 4 s / actuate)		Signal light lights up in red
	Interruption in the menu display (other setting options possible)		Signal light flashes red
	Tool not required/do not use		Signal light lights up in blue
	Tool required/use		Signal light flashes blue

2.3 Safety instructions

WARNING



Risk of accidents due to non-compliance with the safety instructions!

Non-compliance with the safety instructions can be fatal!

- Carefully read the safety instructions in this manual!
- Observe the accident prevention regulations and any regional regulations!
- Inform persons in the working area that they must comply with the regulations!



Risk of injury from electrical voltage!

Voltages can cause potentially fatal electric shocks and burns on contact. Even low voltages can cause a shock and lead to accidents.

- Never touch live components such as welding current sockets or stick, tungsten or wire electrodes!
- Always place torches and electrode holders on an insulated surface!
- Wear the full personal protective equipment (depending on the application)!
- The machine may only be opened by qualified personnel!
- The device must not be used to defrost pipes!



Hazard when interconnecting multiple power sources!

If a number of power sources are to be connected in parallel or in series, only a technical specialist may interconnect the sources as per standard IEC 60974-9:2010: Installation and use and German Accident Prevention Regulation BVG D1 (formerly VBG 15) or country-specific regulations.

Before commencing arc welding, a test must verify that the equipment cannot exceed the maximum permitted open circuit voltage.

- Only qualified personnel may connect the machine.
- When taking individual power sources out of operation, all mains and welding current leads must be safely disconnected from the welding system as a whole. (Hazard due to reverse polarity voltage!)
- Do not interconnect welding machines with pole reversing switch (PWS series) or machines for AC welding since a minor error in operation can cause the welding voltages to be combined, which is not permitted.



Risk of injury due to radiation or heat!

Arc radiation can lead to skin and eye injuries.

Contact with hot workpieces and sparks can lead to burns.

- Use hand shield or welding helmet with the appropriate safety level (depends on the application).
- Wear dry protective clothing (e.g. hand shield, gloves, etc.) in accordance with the applicable regulations of your country.
- Persons who are not directly involved should be protected with a welding curtain or suitable safety screen against radiation and the risk of blinding!

⚠ WARNING**Risk of injury due to improper clothing!**

During arc welding, radiation, heat and voltage are sources of risk that cannot be avoided. The user has to be equipped with the complete personal protective equipment at all times. The protective equipment has to include:

- Respiratory protection against hazardous substances and mixtures (fumes and vapours); otherwise implement suitable measures such as extraction facilities.
- Welding helmet with proper protection against ionizing radiation (IR and UV radiation) and heat.
- Dry welding clothing (shoes, gloves and body protection) to protect against warm environments with conditions comparable to ambient temperatures of 100 °C or higher and arcing and work on live components.
- Hearing protection against harming noise.

**Explosion risk!**

Apparently harmless substances in closed containers may generate excessive pressure when heated.

- Move containers with inflammable or explosive liquids away from the working area!
- Never heat explosive liquids, dusts or gases by welding or cutting!

**Fire hazard!**

Due to the high temperatures, sparks, glowing parts and hot slag that occur during welding, there is a risk of flames.

- Be watchful of potential sources of fire in the working area!
- Do not carry any easily inflammable objects, e.g. matches or lighters.
- Ensure suitable fire extinguishers are available in the working area!
- Thoroughly remove any residue of flammable materials from the workpiece prior to starting to weld.
- Only further process workpieces after they have cooled down. Do not allow them to contact any flammable materials!

⚠ CAUTION



Smoke and gases!

Smoke and gases can lead to breathing difficulties and poisoning. In addition, solvent vapour (chlorinated hydrocarbon) may be converted into poisonous phosgene due to the ultraviolet radiation of the arc!

- Ensure that there is sufficient fresh air!
- Keep solvent vapour away from the arc beam field!
- Wear suitable breathing apparatus if appropriate!



Noise exposure!

Noise exceeding 70 dBA can cause permanent hearing damage!

- Wear suitable ear protection!
- Persons located within the working area must wear suitable ear protection!



According to IEC 60974-10, welding machines are divided into two classes of electromagnetic compatibility (the EMC class can be found in the Technical data) > see 8.3 chapter:



Class A machines are not intended for use in residential areas where the power supply comes from the low-voltage public mains network. When ensuring the electromagnetic compatibility of class A machines, difficulties can arise in these areas due to interference not only in the supply lines but also in the form of radiated interference.



Class B machines fulfil the EMC requirements in industrial as well as residential areas, including residential areas connected to the low-voltage public mains network.

Setting up and operating

When operating arc welding systems, in some cases, electro-magnetic interference can occur although all of the welding machines comply with the emission limits specified in the standard. The user is responsible for any interference caused by welding.

In order to **evaluate** any possible problems with electromagnetic compatibility in the surrounding area, the user must consider the following: (see also EN 60974-10 Appendix A)

- Mains, control, signal and telecommunication lines
- Radios and televisions
- Computers and other control systems
- Safety equipment
- The health of neighbouring persons, especially if they have a pacemaker or wear a hearing aid
- Calibration and measuring equipment
- The immunity to interference of other equipment in the surrounding area
- The time of day at which the welding work must be carried out

Recommendations for reducing interference emission

- Mains connection, e.g. additional mains filter or shielding with a metal tube
- Maintenance of the arc welding system
- Welding leads should be as short as possible and run closely together along the ground
- Potential equalization
- Earthing of the workpiece. In cases where it is not possible to earth the workpiece directly, it should be connected by means of suitable capacitors.
- Shielding from other equipment in the surrounding area or the entire welding system



Electromagnetic fields!

The power source may cause electrical or electromagnetic fields to be produced which could affect the correct functioning of electronic equipment such as IT or CNC devices, telecommunication lines, power cables, signal lines and pacemakers.



- Observe the maintenance instructions > see 6.3 chapter!
- Unwind welding leads completely!
- Shield devices or equipment sensitive to radiation accordingly!
- The correct functioning of pacemakers may be affected (obtain advice from a doctor if necessary).

⚠ CAUTION**Obligations of the operator!**

The respective national directives and laws must be complied with when operating the machine!

- Implementation of national legislation relating to framework directive 89/391/EEC on the introduction of measures to encourage improvements in the safety and health of workers at work and associated individual guidelines.
- In particular, directive 89/655/EEC concerning the minimum safety and health requirements for the use of work equipment by workers at work.
- The regulations applicable to occupational safety and accident prevention in the country concerned.
- Setting up and operating the machine as per IEC 60974.-9.
- Brief the user on safety-conscious work practices on a regular basis.
- Regularly inspect the machine as per IEC 60974.-4.



The manufacturer's warranty becomes void if non-genuine parts are used!

- ***Only use system components and options (power sources, welding torches, electrode holders, remote controls, spare parts and replacement parts, etc.) from our range of products!***
- ***Only insert and lock accessory components into the relevant connection socket when the machine is switched off.***

Requirements for connection to the public mains network

High-performance machines can influence the mains quality by taking current from the mains network. For some types of machines, connection restrictions or requirements relating to the maximum possible line impedance or the necessary minimum supply capacity at the interface with the public network (Point of Common Coupling, PCC) can therefore apply. In this respect, attention is also drawn to the machines' technical data. In this case, it is the responsibility of the operator, where necessary in consultation with the mains network operator, to ensure that the machine can be connected.

2.4 Transport and installation

⚠ WARNING**Risk of injury due to improper handling of shielding gas cylinders!**

Improper handling and insufficient securing of shielding gas cylinders can cause serious injuries!

- Observe the instructions from the gas manufacturer and any relevant regulations concerning the use of compressed air!
- Do not attach any element to the shielding gas cylinder valve!
- Prevent the shielding gas cylinder from heating up.

CAUTION



Risk of accidents due to supply lines!

During transport, attached supply lines (mains leads, control cables, etc.) can cause risks, e.g. by causing connected machines to tip over and injure persons!

- Disconnect all supply lines before transport!



Risk of tipping!

There is a risk of the machine tipping over and injuring persons or being damaged itself during movement and set up. Tilt resistance is guaranteed up to an angle of 10° (according to IEC 60974-1).

- Set up and transport the machine on level, solid ground.
- Secure add-on parts using suitable equipment.



Risk of accidents due to incorrectly installed leads!

Incorrectly installed leads (mains, control and welding leads or intermediate hose packages) can present a tripping hazard.

- Lay the supply lines flat on the floor (avoid loops).
- Avoid laying the leads on passage ways.



Risk of injury from heated coolant and its connections!

The coolant used and its connection or connection points can heat up significantly during operation (water-cooled version). When opening the coolant circuit, escaping coolant may cause scalding.

- Open the coolant circuit only when the power source or cooling unit is switched off!
- Wear proper protective equipment (protective gloves)!
- Seal open connections of the hose leads with suitable plugs.



The units are designed for operation in an upright position!

Operation in non-permissible positions can cause equipment damage.

- ***Only transport and operate in an upright position!***



Accessory components and the power source itself can be damaged by incorrect connection!

- ***Only insert and lock accessory components into the relevant connection socket when the machine is switched off.***
- ***Comprehensive descriptions can be found in the operating instructions for the relevant accessory components.***
- ***Accessory components are detected automatically after the power source is switched on.***



Protective dust caps protect the connection sockets and therefore the machine against dirt and damage.

- ***The protective dust cap must be fitted if there is no accessory component being operated on that connection.***
- ***The cap must be replaced if faulty or if lost!***

3 Intended use

⚠ WARNING

§ Hazards due to improper usage!
The machine has been constructed to the state of the art and any regulations and standards applicable for use in industry and trade. It may only be used for the welding procedures indicated at the rating plate. Hazards may arise for persons, animals and material objects if the equipment is not used correctly. No liability is accepted for any damages arising from improper usage!

- The equipment must only be used in line with its designated purpose and by trained or expert personnel!
- Do not improperly modify or convert the equipment!

3.1 Applications

Multi-process welding machine for arc welding covering the following welding procedures:

Machine series	Main procedure for MIG/MAG welding											Secondary procedure			
	Standard arc					Pulsed arc						TIG welding (Liftarc)	MMA welding	Gouging	Positionweld
	MIG/MAG XQ	forceArc XQ	rootArc XQ	coldArc XQ	wiredArc XQ	MIG/MAG pulse XQ	forceArc puls XQ	rootArc puls XQ	coldArc puls XQ	acArc puls XQ	wiredArc puls XQ				
Titan XQ AC	✓	✓	✓	✓	✓	✓	✓	✓	✓	✓	✓	✓	✓	✓	✓
Titan XQ / XQ C	✓	✓	✓	✓	✓	✓	✓	✓	✓	✗	✓	✓	✓	✓	✓
Phoenix XQ / XQ C	✓	✓	✓	✗	✗	✓	✓	✓	✗	✗	✗	✓	✓	✓	☒
Taurus XQ / XQ C	✓	✓	✓	✗	✗	✗	✗	✗	✗	✗	✗	✓	✓	✓	✗
Taurus XQ Basic	✓	✗	✗	✗	✗	✗	✗	✗	✗	✗	✗	✓	✓	✓	✗

[1] Aluminium-welding tasks

3.2 Documents which also apply

3.2.1 Warranty

For more information refer to the "Warranty registration" brochure supplied and our information regarding warranty, maintenance and testing at www.ewm-group.com!

3.2.2 Declaration of Conformity



This product corresponds in its design and construction to the EU directives listed in the declaration. The product comes with a relevant declaration of conformity in the original.

The manufacturer recommends carrying out the safety inspection according to national and international standards and guidelines every 12 months (from commissioning).

3.2.3 Welding in environments with increased electrical hazards



Power sources with this marking can be used for welding in an environment with increased electrical hazard (e.g. boilers). For this purpose, appropriate national or international regulations must be followed. The power source must not be placed in the danger zone!

3.2.4 Service documents (spare parts and circuit diagrams)

WARNING



No improper repairs and modifications!

To prevent injuries and damage to the machine, only competent personnel (authorised service personnel) are allowed to repair or modify the machine.

Unauthorised manipulations will invalidate the warranty!

- Instruct competent personnel (authorised service personnel) to repair the machine.

Original copies of the circuit diagrams are enclosed with the unit.

Spare parts can be obtained from the relevant authorised dealer.

3.2.5 Calibration/Validation

An original certificate is enclosed with the product. The manufacturer recommends calibration / validation at intervals of 12 months (from commissioning).

3.2.6 Part of the complete documentation

This document is part of the complete documentation and valid only in combination with all other parts of these instructions! Read and observe the operating instructions for all system components, especially the safety instructions!

The illustration shows a general example of a welding system.

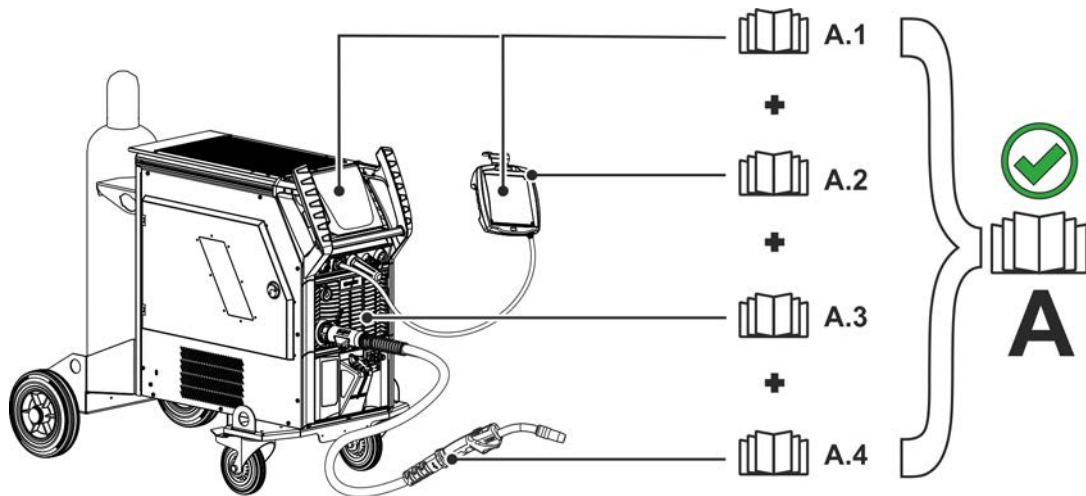

Figure 3-1

Item	Documentation
A.1	Controller
A.2	Remote adjuster
A.3	Power source
A.4	Welding torch
A	Complete documentation

4 Machine description – quick overview

4.1 Machine configuration

The following table shows the different design variants (expansion stages) of the device series XQ:

Type			Figure	Transport properties				Torch cooling	
				Wheel kit, narrow track, without cylinder bracket	Pallet base, without cylinder bracket	Wheel kit, single cylinder bracket	Wheel kit, double cylinder bracket	Gas	Water (coolant)
F06	R1	G		✗	✗	✓	✗	✓	✗
F06	R1	W		✗	✗	✓	✗	✗	✓
F06	R2	G		✗	✗	✗	✓	✓	✗
F06	R2	W		✗	✗	✗	✓	✗	✓
F06	RS	G		✓	✗	✗	✗	✓	✗
F06	RS	W		✓	✗	✗	✗	✗	✓
F06	P	G		✗	✓	✗	✗	✓	✗
F06	P	W		✗	✓	✗	✗	✗	✓

Figure 4-1

4.2 Front view / side view from the right

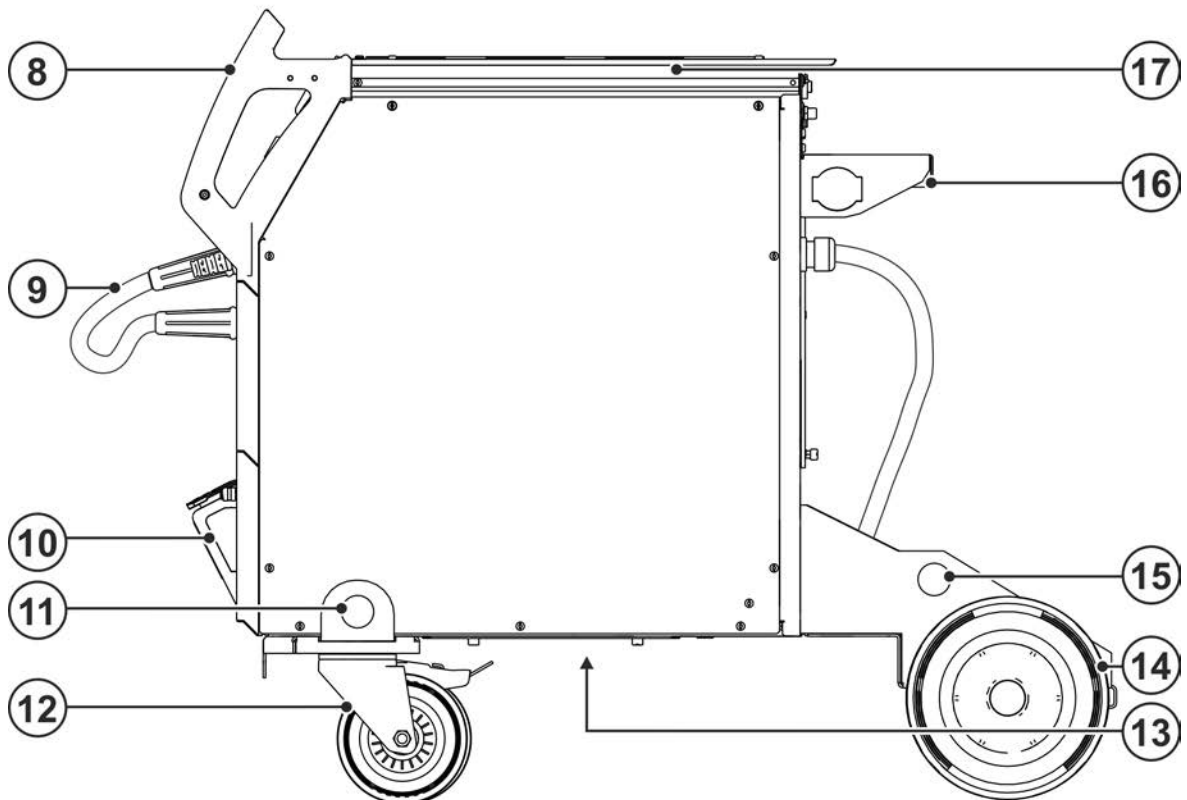
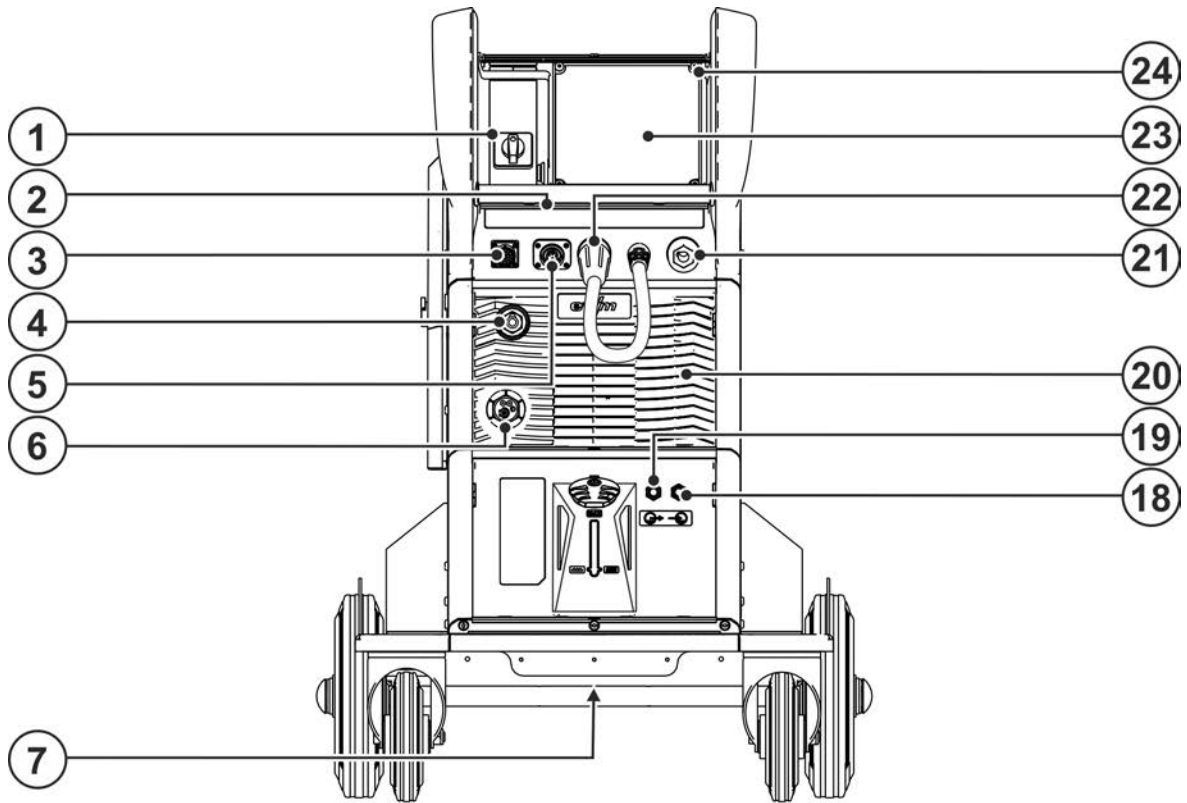









Figure 4-2

Item	Symbol	Description
1		Main Switch Switching the machine on or off.
2		LED status bar - display of operating status The operating status is indicated by a light guide > see 5.1.11 chapter.
3		19-pole connection socket (analogue) For connecting analogue accessory components (remote control, welding torch control lead, etc.)
4		Park socket, polarity selection plug Retainer for the polarity selection plug in MMA mode or for transport.
5		7-pole connection socket (digital) For connecting digital accessory components
6		Welding torch connection (Euro torch connector) Welding current, shielding gas and torch trigger integrated
7		Coolant drain plug > see 6.3.2 chapter
8		Carrying handle
9		Polarity selection plug, welding current cable > see 5.1.13 chapter
10		Coolant tank > see 5.1.5 chapter
11		Lifting lug > see 5.1.1 chapter
12		Wheels with locking brake
13		Inlet opening for cooling air (torch cooling) Dirt filter can be retrofitted
14		Wheels, fixed castors
15		Lifting lug > see 5.1.1 chapter
16		Gas cylinder holder
17		Aluminium extrusion profile flexFit Individual mounting option for accessories and options
18		Quick connect coupling, red Coolant return from the welding torch
19		Quick connect coupling, blue Coolant supply to the welding torch
20		Cooling air outlet
21		Connection socket, “-” welding current How to connect the accessories depends on the welding procedure. Please observe the connection description for the corresponding welding procedure > see 5 chapter.
22		Connection socket, “+” welding current How to connect the accessories depends on the welding procedure. Please observe the connection description for the corresponding welding procedure > see 5 chapter.
23		Machine control (see the relevant control operating instructions)
24		Protective cap > see 5.1.12 chapter

4.3 Rear view / side view from left

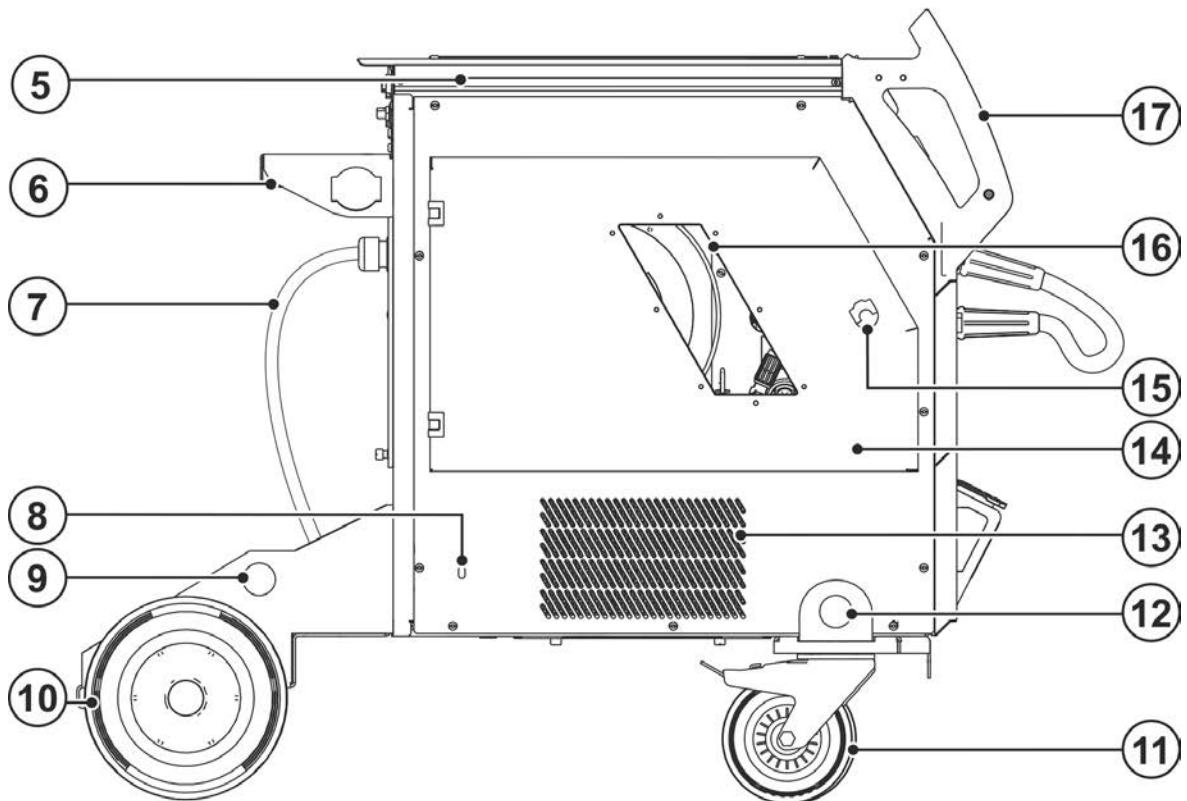
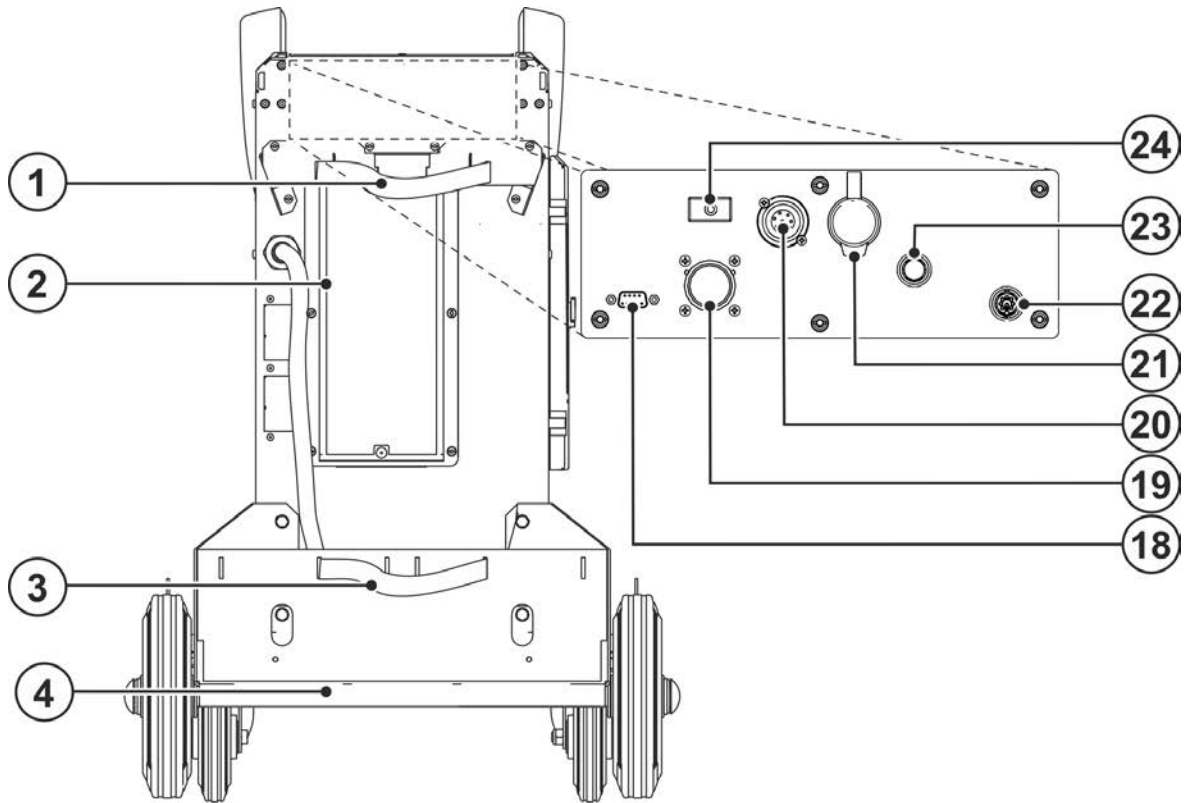









Figure 4-3

Item	Symbol	Description
1		Securing elements for shielding gas cylinder (strap/chain)
2		Cooling air inlet Dirt filter optional > see 6.3.1 chapter
3		Securing elements for shielding gas cylinder (strap/chain)
4		Bracket for shielding gas cylinder
5		Aluminium extrusion profile flexFit Individual mounting option for accessories and options
6		Gas cylinder holder
7		Mains connection cable > see 5.1.8 chapter
8		Service opening for coolant pump > see 7.5 chapter
9		Lifting lug > see 5.1.1 chapter
10		Wheels, fixed castors
11		Wheels, guide castors
12		Lifting lug > see 5.1.1 chapter
13		Outlet opening cooling air (torch cooling)
14		Protective cap Cover for the wire feed mechanism and other operating elements. Depending on the machine series, additional stickers with information on the replacement parts and JOB lists will be located on the inside.
15		Rotary closure Locking of the protective cap, wire feed mechanism
16		Wire spool inspection window Check wire supply
17		Carrying handle
18		Connection socket (9-pole) - D-Sub PC interface > see 5.8 chapter
19		Connection socket- 19-pole, analogue - optional Interface for automated welding > see 5.7.1 chapter
20		7-pole connection socket (digital) For connecting digital accessory components
21		Connection socket - RJ45 - Option Network connection > see 5.10 chapter
22		Connection socket for hand scanner - optional Component identification Xnet > see 5.9 chapter
23		Connection thread - G$\frac{1}{4}$" Shielding gas connection (inlet)
24		Key button, Automatic cutout Wire feed motor supply voltage fuse (press to reset a triggered fuse)

4.4 Inside view

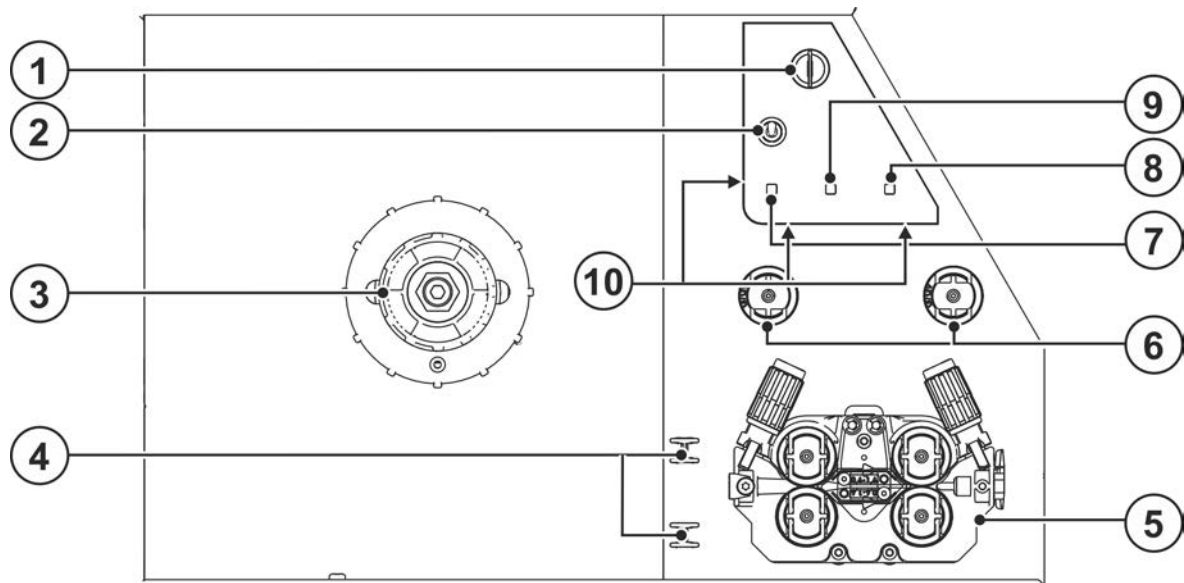

Figure 4-4

Item	Symbol	Description
1		Key switch for protection against unauthorised use > see 5.6 chapter ----- changes possible, G front drive-4x-EX ----- changes not possible.
2		Welding torch function changeover switch (special welding torch required) Programm --- Changing over programs or JOBS Up / Down --- Infinite adjustment of welding performance.
3		Wire spool holder
4		Holder for guide or capillary tube (accessory)
5		Wire feed unit > see 5.2.4 chapter
6		Holder for wire feed rolls Holder for storing spare wire rolls.
7		Push-button for wire return Potential and gas-free reverse inching of the wire electrode
8		Wire inching push-button Potential and gas-free inching of the wire electrode > see 5.2.4.3 chapter.
9		Push-button gas test / rinse hose package > see 5.1.10 chapter
10		Lighting, inside In power-saving mode and with MMA or TIG welding, the lighting is switched off.

5 Design and function

⚠ WARNING



Risk of injury from electrical voltage!

Contact with live parts, e.g. power connections, can be fatal!

- Observe the safety information on the first pages of the operating instructions!
- Commissioning must be carried out by persons who are specifically trained in handling power sources!
- Connect connection or power cables while the machine is switched off!

Read and observe the documentation to all system and accessory components!

5.1 Transport and installation

5.1.1 Lifting by crane

⚠ WARNING



Risk of injury during lifting by crane!

When lifting the machine by crane, persons may be severely injured by falling machines or mount-on components.

- Simultaneous lifting of system components such as power source, wire feeder or cooling unit without suitable crane components is not allowed. Each system component has to be lifted separately!
- Remove any supply leads and accessories before lifting by crane (e.g. hose package, wire spool, shielding gas cylinder, toolbox, wire feeder, remote control, etc.)!
- Properly close and lock all casing covers and protective caps before lifting by crane!
- Use the correct number of hoisting equipment of the right size in the correct position! Observe craning principle > see 5.1.1.1 chapter!
- Devices with lifting eyes: Always lift all lifting eyes simultaneously!
- Devices with pallet bottom (feet): Pull the straps through the openings of the feet (hooking hoisting equipment in the openings is not sufficient).
- When using retrofitted craning frames etc.: always use at least two lifting points positioned as far apart as possible – observe option description.
- Avoid any jerky movements!
- Ensure that the load is distributed evenly! • Use chain hoists and chain slings of the same length only!
- Stay outside the danger zone underneath the machine!
- Observe the regulations regarding occupational safety and accident prevention for the respective country.

5.1.1.1 Craning principle

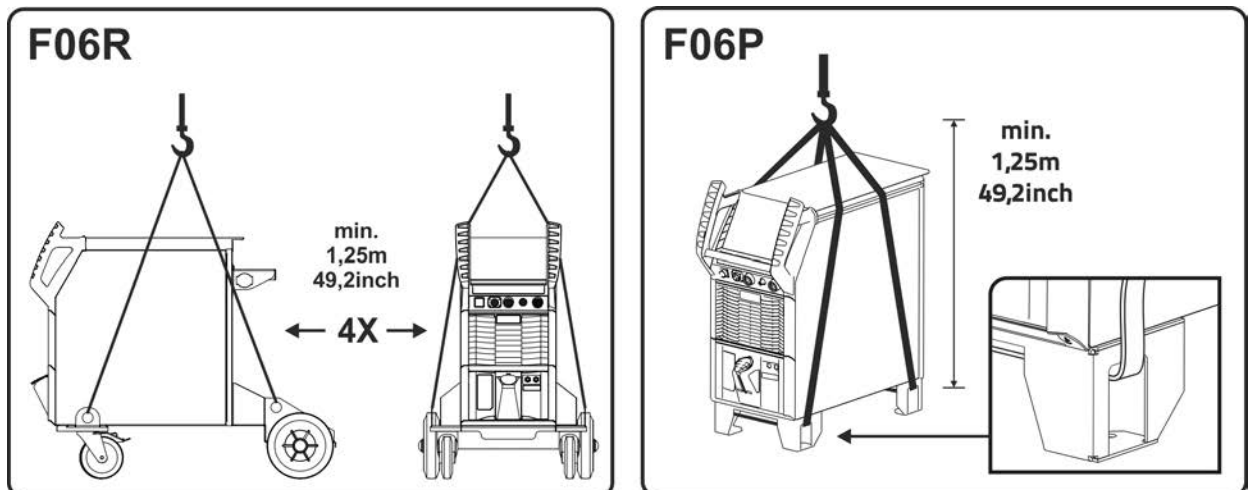

Figure 5-1

5.1.2 Ambient conditions



The machine must not be operated in the open air and must only be set up and operated on a suitable, stable and level base!

- **The operator must ensure that the ground is non-slip and level, and provide sufficient lighting for the place of work.**
- **Safe operation of the machine must be guaranteed at all times.**



Equipment damage due to contamination!

Unusually high amounts of dust, acids, corrosive gases or substances can damage the machine (observe maintenance intervals > see 6.3 chapter).

- **Avoid large amounts of smoke, steam, oily fumes, grinding dust and corrosive ambient air!**

In operation

Temperature range of the ambient air:

- -25 °C to +40 °C (-13 °F to 104 °F) ^[1]

Relative humidity:

- up to 50 % at 40 °C (104 °F)
- up to 90 % at 20 °C (68 °F)

Transport and storage

Storage in a closed room, temperature range of the ambient air:

- -30 °C to +70 °C (-22 °F to 158 °F) ^[1]

Relative humidity

- up to 90 % at 20 °C (68 °F)

^[1] Ambient temperature dependent on coolant! Observe the coolant temperature range of the torch cooling

5.1.3 Machine cooling



Insufficient ventilation results in a reduction in performance and equipment damage.

- **Observe the ambient conditions!**
- **Keep the cooling air inlet and outlet clear!**
- **Observe the minimum distance of 0.5 m from obstacles!**

5.1.4 Workpiece lead, general

CAUTION



Risk of burning due to incorrect welding current connection!

If the welding current plugs (machine connections) are not locked or if the workpiece connection is contaminated (paint, corrosion), these connections and leads can heat up and cause burns when touched!

- Check welding current connections on a daily basis and lock by turning to the right when necessary.
- Clean workpiece connection thoroughly and secure properly. Do not use structural parts of the workpiece as welding current return lead!

5.1.5 Welding torch cooling system



Material damage due to unsuitable coolants!

Unsuitable coolant, coolants mixed with other types / liquids or use in an unsuitable temperature range will result in material damage and loss of the manufacturer's warranty!

- **Operation without coolant is not permitted! Dry running will destroy the cooling components such as the coolant pump, welding torch and hose packages.**
- **Only use the coolants described in these instructions for the specified ambient conditions (temperature range) > see 5.1.5.2 chapter.**
- **Do not mix coolants of different types (including those described in these instructions).**
- **When changing the coolant, all liquid must be replaced and the cooling system flushed.**

Dispose of the coolant in accordance with local regulations and the material safety data sheets.

5.1.5.1 Functional characteristics

The cooling system of this machine series is designed to optimise the operating conditions and is temperature- and flow-monitored to protect against damage. Limit values > see 8.2 chapter for warnings and errors in the machine (adjustable depending on control system) are stored for monitoring and control of the cooling system. If the cooling system is faulty or overloaded, an error message appears and the welding process is switched off in a controlled manner.

5.1.5.2 Permitted torch coolant

Coolant	Temperature range
blueCool -10	-10 °C to +40 °C (14 °F to +104 °F)
KF 23E (Standard)	-10 °C to +40 °C (14 °F to +104 °F)
KF 37E	-20 °C to +30 °C (-4 °F to +86 °F)
blueCool -30	-30 °C to +40 °C (-22 °F to +104 °F)

5.1.5.3 Maximal hose package length

All information relates to the total hose package length of the complete welding system and presents exemplary configurations (of components of the EWM product portfolio with standard lengths). A straight kink-free installation is to be ensured, taking into account the max. delivery height.

Pump: Pmax = 3.5 bar (0.35 MPa)

Power source	Hose package	Wire feeder	miniDrive	Welding torch	max.
Compact	✘	✘	✔ (25 m / 82 ft.)	✔ (5 m / 16 ft.)	30 m 98 ft.
	✔ (20 m / 65 ft.)	✔	✘	✔✔ (5 m / 16 ft.)	
Decompact	✔ (25 m / 82 ft.)	✔	✘	✔ (5 m / 16 ft.)	
	✔ (15 m / 49 ft.)	✔	✔ (10 m / 32 ft.)	✔ (5 m / 16 ft.)	

5.1.5.4 Adding coolant

After switching on the machine, the coolant pump runs for a defined time (filling the hose package). If the machine does not detect sufficient coolant flow during this time, the coolant pump is switched off (protection against damage caused by dry running). At the same time, the welding data display signals the coolant error. If there is sufficient coolant flow, the coolant pump is switched off before the defined time has elapsed (operational readiness).

If there is less coolant in the coolant tank than the minimum required you may need to vent the coolant circuit. In this case the welding machine will automatically shut down the coolant pump and signal an error, > see 7.4 chapter.

The unit is supplied ex works with a minimum level of coolant.



The level of coolant must never fall below the "MIN" mark.

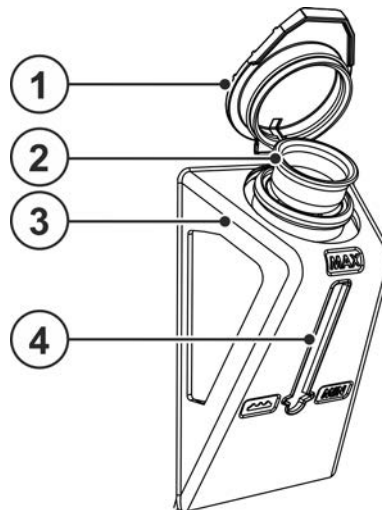

Figure 5-2

Item	Symbol	Description
1		Coolant tank cap
2		Coolant filter sieve
3		Coolant tank > see 5.1.5 chapter
4		Filling level display MIN----- minimum coolant level MAX----- maximum coolant level

- Pull off the coolant tank sealing cover.
- Check filter sieve for cleanliness, clean if necessary and reinsert.
- Top up coolant up to the upper filling level gauge "MAX" and push sealing cover back on.
- Switch on the power source at the main switch.

5.1.6 Notes on the installation of welding current leads

- Incorrectly installed welding current leads can cause faults in the arc (flickering).
- Lay the workpiece lead and hose package of power sources without HF igniter (MIG/MAG) for as long and as close as possible in parallel.
- Lay the workpiece lead and hose package of power sources with HF igniter (TIG) for as long as possible in parallel with a distance of 20 cm to avoid HF sparkover.
- Always keep a distance of at least 20 cm to leads of other power sources to avoid interferences
- Always keep leads as short as possible! For optimum welding results max. 30 m (welding lead + intermediate hose package + torch lead).

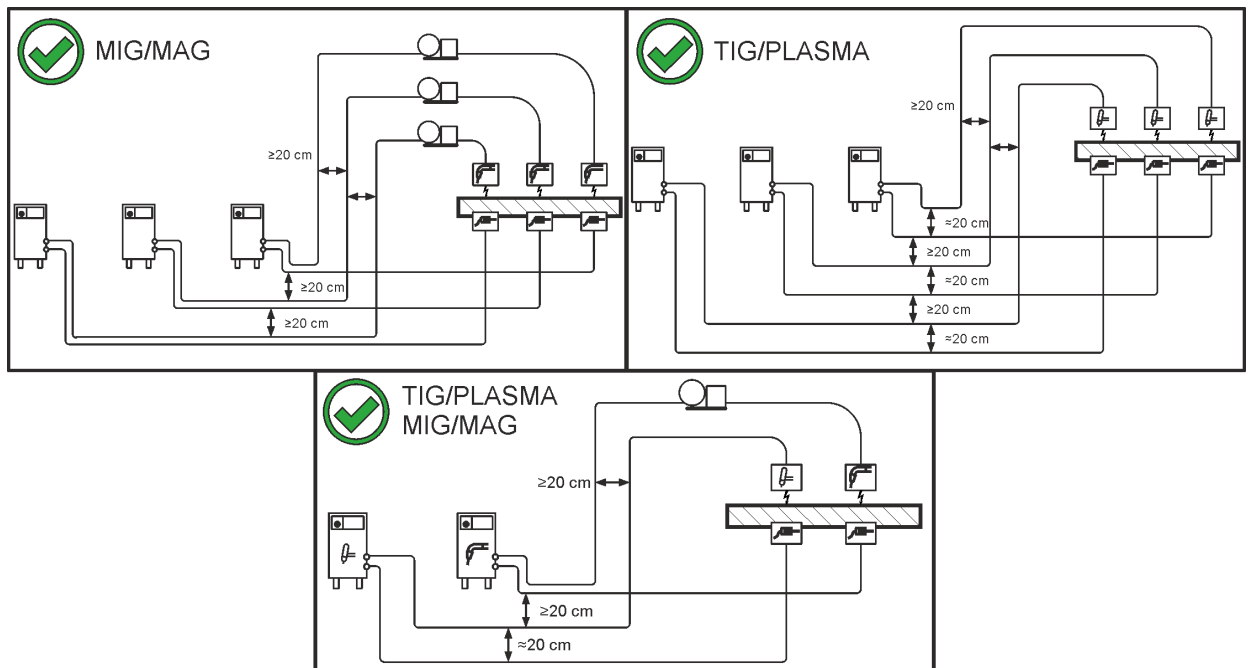

Figure 5-3

- Use an individual welding lead to the workpiece for each welding machine!

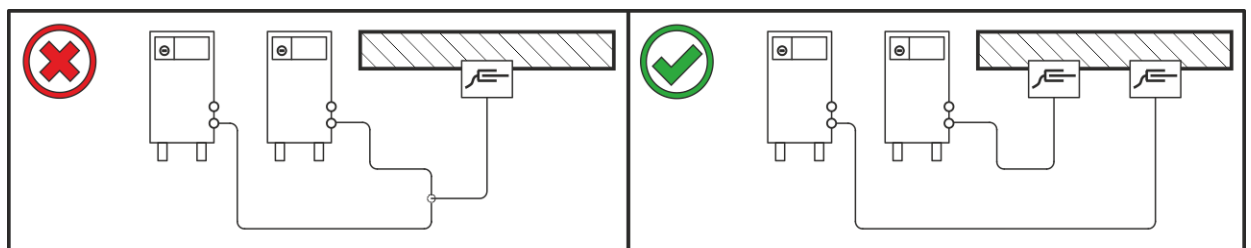

Figure 5-4

- Fully unroll welding current leads, torch hose packages and intermediate hose packages. Avoid loops!
- Always keep leads as short as possible!

Lay any excess cable lengths in meanders.

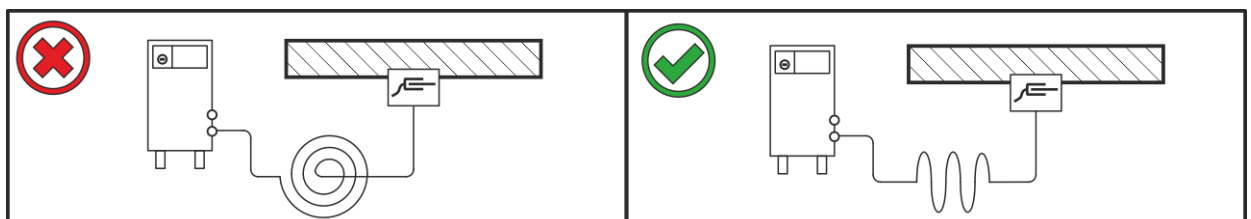

Figure 5-5

5.1.7 Stray welding currents

⚠ WARNING



Risk of injury due to stray welding currents!

Stray welding currents can destroy protective earth conductors, damage machines and electronic devices and cause overheating of components, leading to fire.

- Check that all welding current connections are firmly secured and electrical connections are in perfect condition.
- Set up, attach or suspend all conductive power source components such as casing, transport vehicles and crane frames so they are insulated.
- Do not place any other electronic devices such as drills or angle grinders on the power source, transport vehicle or crane frames unless they are insulated.
- Always put welding torches and electrode holders on an insulated surface when they are not in use.

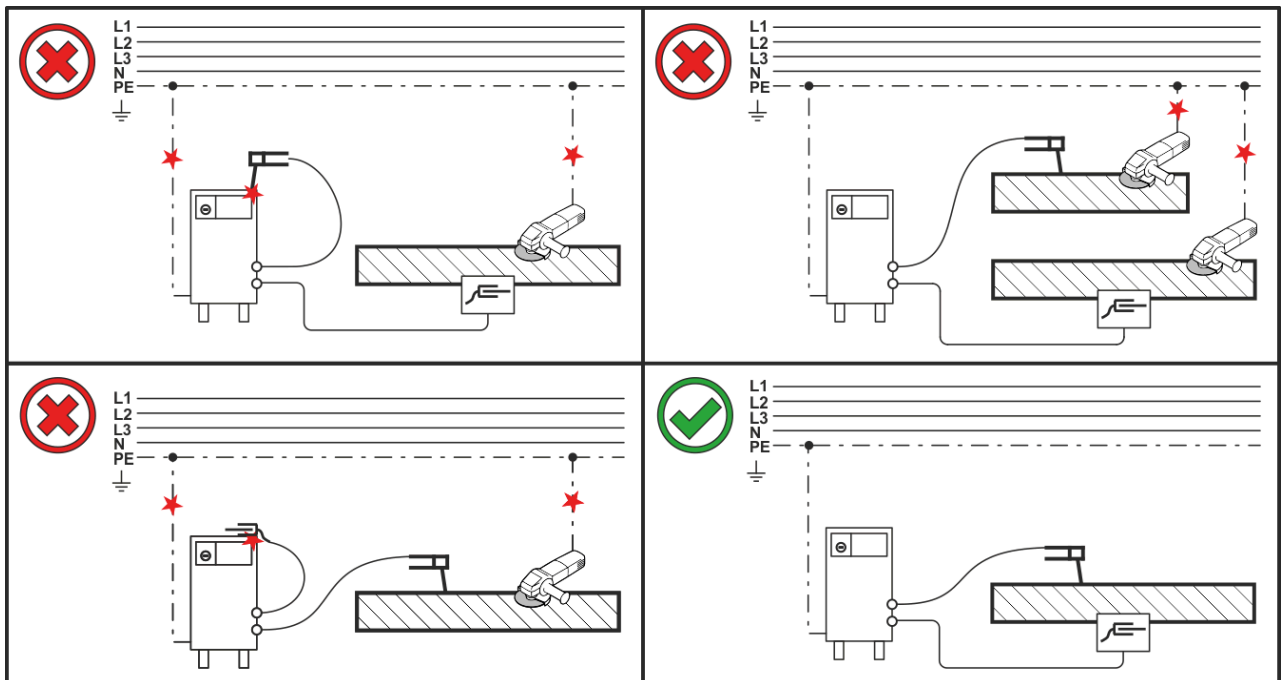

Figure 5-6

5.1.8 Mains connection

⚠ DANGER



Hazards caused by improper mains connection!

An improper mains connection can cause injuries or damage property!

- The connection (mains plug or cable), the repair or voltage adjustment of the device must be carried out by a qualified electrician in accordance with the respective local laws or national regulations!
- The mains voltage indicated on the rating plate must match the supply voltage.
- Only operate machine using a socket that has correctly fitted protective earth.
- Mains plug, socket and lead must be checked by a qualified electrician on a regular basis!
- When operating the generator, always ensure it is earthed as stipulated in the operating instructions. The network created must be suitable for operating machines according to protection class I.



The welding power source is equipped with an internal clamp device for multiple mains voltages. The currently set mains voltage of the power source must match the supply voltage! The following steps have to be carried out:

- **Visual inspection - comparison between the currently set mains voltage at the power source and the supply voltage > see 5.1.8.1 chapter**

- **Adaptation and marking of the mains voltage > see 5.1.8.2 chapter**
- **Carry out a safety check after intervention in the machine > see 5.1.8.3 chapter!**

5.1.8.1 Visual inspection of the set mains voltage

The set mains voltage is marked on the rating plate and the label on the mains connection cable by a marking. If the marked mains voltage range coincides with the supply voltage, further commissioning may take place. If the specifications for mains and supply voltage do not match, the mains voltage in the machine must be reconnected to the supply voltage > see 5.1.8.2 chapter.

Removed or not clearly identifiable adhesive labels must be replaced!

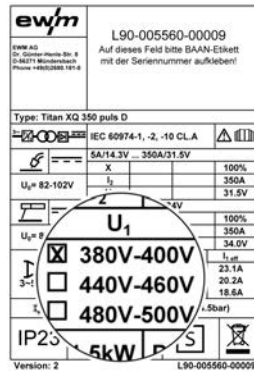

Example of rating plate

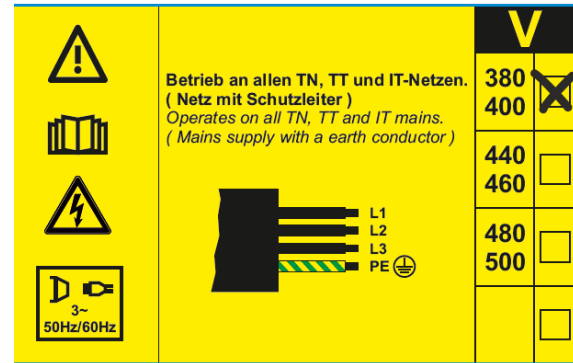

Adhesive label of mains connection cable

Figure 5-7

5.1.8.2 Adjusting the power source to the mains voltage

The mains voltage is adapted by replugging the operating voltage plug on the printed circuit board VB xx0 into the power source.

The machine can be reconnected between three possible voltage ranges:

1. 380 V to 400 V (ex works)
2. 440 V to 460 V
3. 480 V to 500 V

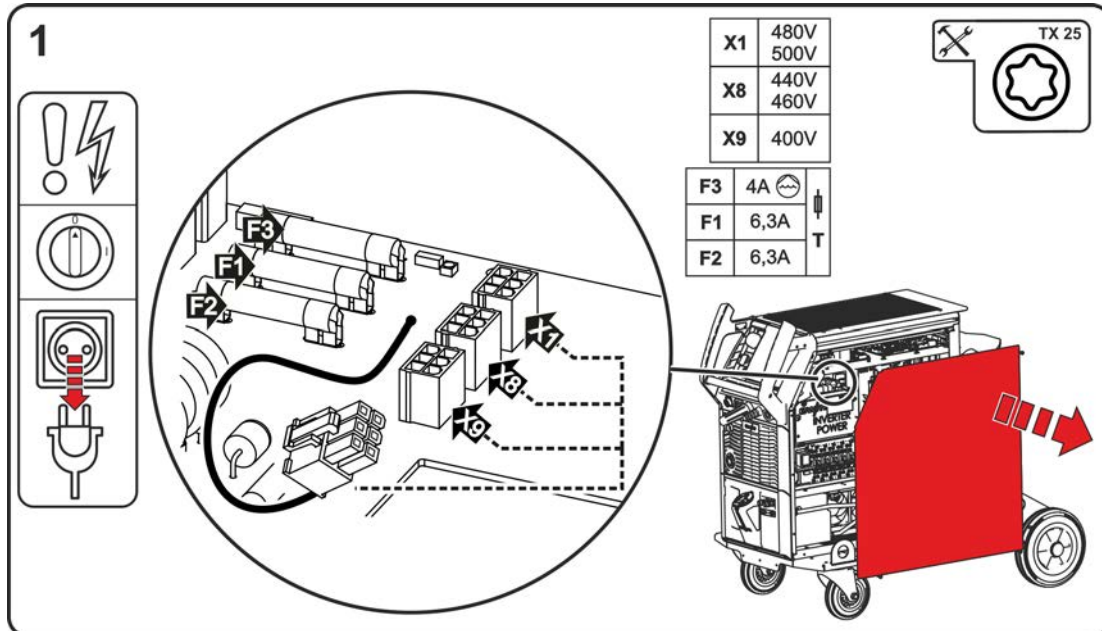

Figure 5-8

- Switch off machine at the main switch.
- Disconnect mains plug.
- Loosen the fastening screws from the housing cover. Open the housing cover at the side and lift it up.
- Reconnect operating voltage plug (printed circuit board VB xx0) to the corresponding voltage range of the supply voltage (380V/400V ex works).
- Hook housing cover from above into the aluminium continuous casting profile flexFit and secure with fastening screws.
- Install a mains plug which is permissible for the selected mains voltage to the mains cable. Identify the selected mains voltage on the rating plate and on the adhesive label of mains connection cable.

5.1.8.3 Re-commissioning

⚠ WARNING



Dangers resulting from failure to perform test after conversion!

Before reconnection, "Inspection and Testing during Operation" according to IEC/BS EN 60974-4 "Arc welding systems – Inspection and Testing during Operation" has to be performed!

- Perform test to IEC / DIN EN 60974-4!

5.1.8.4 Mains configuration

The machine may be connected to:

- a three-phase system with four conductors and an earthed neutral conductor
- a three-phase system with three conductors of which any one can be earthed, e.g. the outer conductor

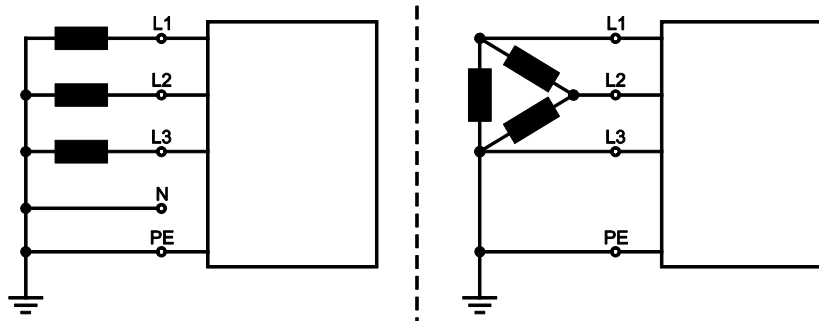

Figure 5-9

Legend

Item	Designation	Colour code
L1	Outer conductor 1	brown
L2	Outer conductor 2	black
L3	Outer conductor 3	grey
N	Neutral conductor	blue
PE	Protective conductor	green-yellow

- Insert mains plug of the switched-off machine into the appropriate socket.

5.1.9 Switching on and system diagnosis

Each time the system is switched on, the entire welding system runs data synchronization and the system diagnostics of the individual components. The duration of the start time (switching on up to welding readiness) depends on the number of connected system components and the information to be exchanged under these devices. This time can take from several seconds to several minutes (e.g. for the system components interconnected for the first time). During this start phase, the system components will display the controller type and, if applicable, software information in the welding data display (if available). This start phase is terminated by display of the nominal values for current, voltage or wire feed speed.

Operation of machine fan and coolant pump

The machine fan and coolant pump in this machine series are temperature- and state-controlled. This ensures that subsystems of the welding machine run only when they are needed. After each switching on, the machine fans run at full power for approx. 2 s, e.g. to blow out dust deposits.

5.1.10 Shielding gas supply (shielding gas cylinder for welding machine)

⚠ WARNING



Risk of injury due to improper handling of shielding gas cylinders! Improper handling and insufficient securing of shielding gas cylinders can cause serious injuries!

- Observe the instructions from the gas manufacturer and any relevant regulations concerning the use of compressed air!
- Lift the shielding gas cylinder onto the receptacle of the shielding gas cylinder and secure with both safety belts provided on the device as standard! Belts must be tight.
- Do not attach any element to the shielding gas cylinder valve!
- Prevent the shielding gas cylinder from heating up.

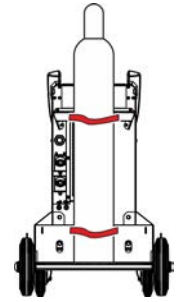

An unhindered shielding gas supply from the shielding gas cylinder to the welding torch is a fundamental requirement for optimum welding results. In addition, a blocked shielding gas supply may result in the welding torch being destroyed.

- **Always re-fit the yellow protective cap when not using the shielding gas connection.**
- **All shielding gas connections must be gas tight.**

5.1.10.1 Pressure regulator connection

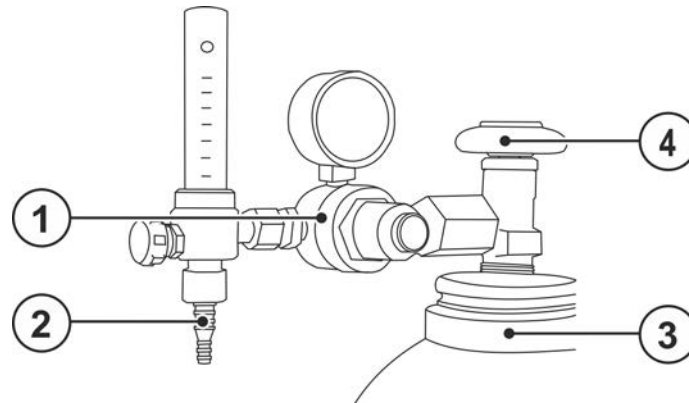

Figure 5-10

Item	Symbol	Description
1		Pressure regulator
2		Output side of the pressure regulator
3		Shielding gas cylinder
4		Cylinder valve

- Before connecting the pressure regulator to the gas cylinder, open the cylinder valve briefly to blow out any dirt.
- Tighten the pressure regulator screw connection on the gas bottle valve to be gas-tight.
- Screw the gas hose connection to the outlet side of the pressure regulator gas-tight.

5.1.10.2 Shielding gas hose connection

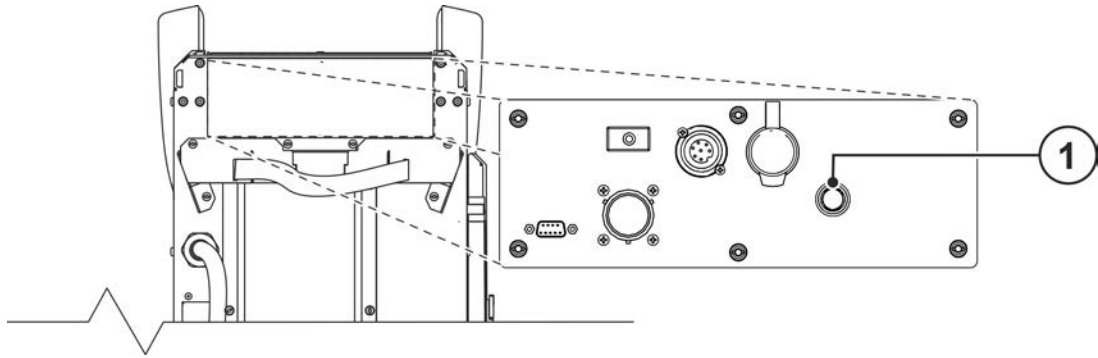

Figure 5-11

Item	Symbol	Description
1		Connection thread - G$\frac{1}{4}$" Shielding gas connection (inlet)

- Screw the gas hose connection to the shielding gas connection (inlet) on the machine gas-tight.

5.1.10.3 Setting the shielding gas volume (gas test)/rinse hose package

- Shielding gas supply as described in chapter Transport and positioning > see 5.1.10 chapter.
- Slowly open the gas cylinder valve.
- Open the pressure regulator.
- Switch on the power source at the main switch.
- Set the relevant gas quantity for the application on the pressure regulator.
- You can activate the gas test on the machine control (see Control operating instructions) or by pressing the "Gas test/rinse hose package " push-button briefly (welding voltage and wire feed motor remain switched off – no unintentional ignition of the arc). Some welding systems have several push-buttons to set the shielding gas. The push-button is generally found near a wire feeder.

Shielding gas flows for around 25 seconds or until the button is pressed again.

If the shielding gas setting is too low or too high, this can introduce air to the weld pool and may cause pores to form. Adjust the shielding gas quantity to suit the welding task!

Welding process	Recommended shielding gas quantity
MAG welding	Wire diameter x 11.5 = l/min
MIG brazing	Wire diameter x 11.5 = l/min
MIG welding (aluminium)	Wire diameter x 13.5 = l/min (100 % argon)

Helium-rich gas mixtures require a higher gas volume!

The table below can be used to correct the gas volume calculated where necessary:

Shielding gas	Factor
75% Ar/25% He	1.14
50% Ar/50% He	1.35
25% Ar/75% He	1.75
100% He	3.16

5.1.11 LED status bar - display of operating status

A light guide on the front of the housing (LED status bar) shows the user the current operating status of the device.

Colour of the LED status bar	Operating status
white (change: light/dark)	Booting (switching on up to welding readiness)
blue	Ready for welding
blue (change: light/dark)	Power-saving mode Standby
green	Welding
yellow	Warning > see 7.2 chapter
red	Error > see 7.1 chapter

5.1.12 Protective flap, welding machine control

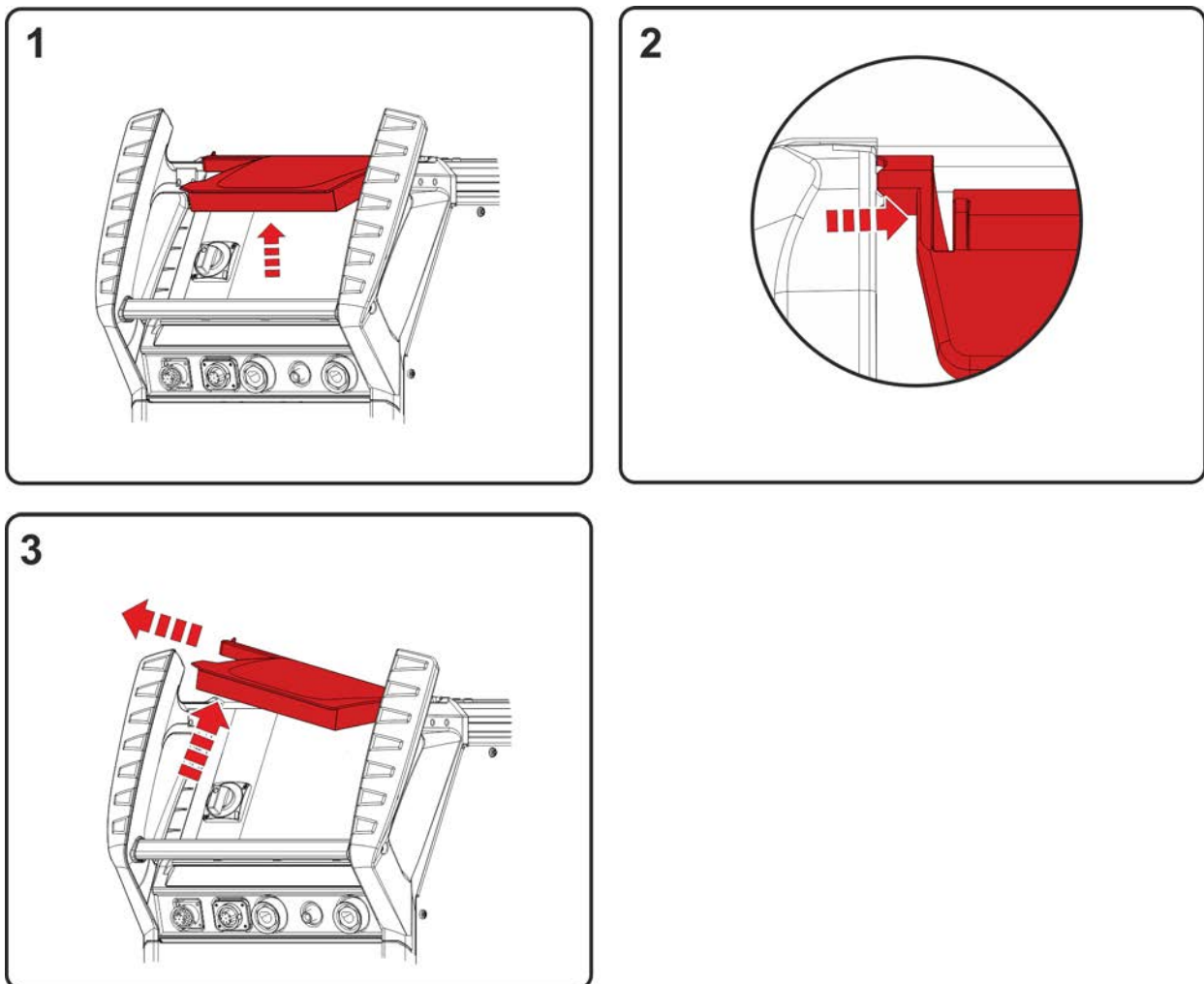

Figure 5-12

- Open the protective cap.
- Apply slight pressure on the left connecting bridge (figure) until the flap's fastening pin can be removed to the left, from top.

5.1.13 Polarity selection plug - changing the welding current polarity

The polarity selection plug allows the adjustment of the welding current polarity (+/-) at the welding torch connection. For example, when welding with varying types of electrodes that require different polarities according to the manufacturer, the welding current polarity can be changed by switching to the corresponding connection socket (+) or (-) for the welding current.

For MMA welding, the welding current plug is inserted into the park socket to release the two welding current connections (+/-) for electrode holder and workpiece lead.

5.2 MIG/MAG welding

5.2.1 Assemble the wire guide

The Euro torch connector is factory-fitted with a guide tube for welding torches with steel liner. Conversion is necessary if a welding torch with a steel liner is used!

- Operate welding torches with a liner > with a guide tube!
- Operate welding torches with a steel liner > with a capillary tube!

Depending on the wire electrode diameter or type, either a steel liner or liner with the correct inner diameter must be inserted in the torch!

Recommendation:

- Use a steel liner when welding hard, unalloyed wire electrodes (steel).
- Use a chrome nickel liner when welding hard, high-alloy wire electrodes (CrNi).
- Use a plastic or teflon liner when welding or brazing soft wire electrodes, high-alloy wire electrodes or aluminium materials.

Preparation for connecting welding torches with a spiral guide:

- Check that the capillary tube is correctly positioned in relation to the central connector!

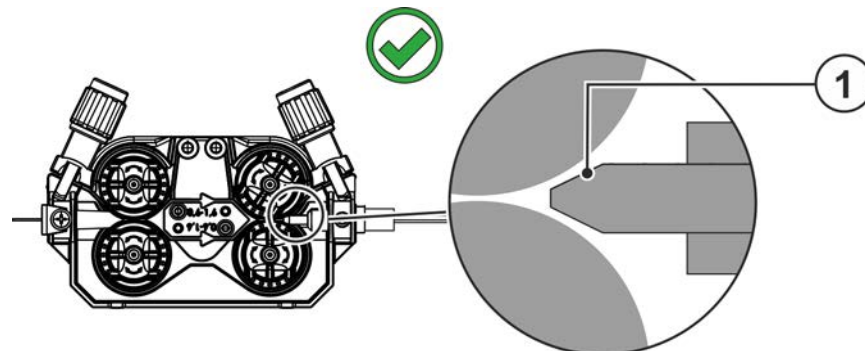

Figure 5-13

Preparation for connecting welding torches with a liner:

- Push forward the capillary tube on the wire feed side in the direction of the Euro torch connector and remove it there.
- Insert the liner guide tube from the Euro torch connector side.
- Carefully insert the welding torch connector with as yet too long a liner into the Euro torch connector and secure with a crown nut.
- Cut off the liner with a liner cutter > see 9 chapter just before the wire feed roller.
- Loosen the welding torch connector and remove.
- Carefully chamfer the cut off end of the liner with a liner sharpener > see 9 chapter and sharpen.

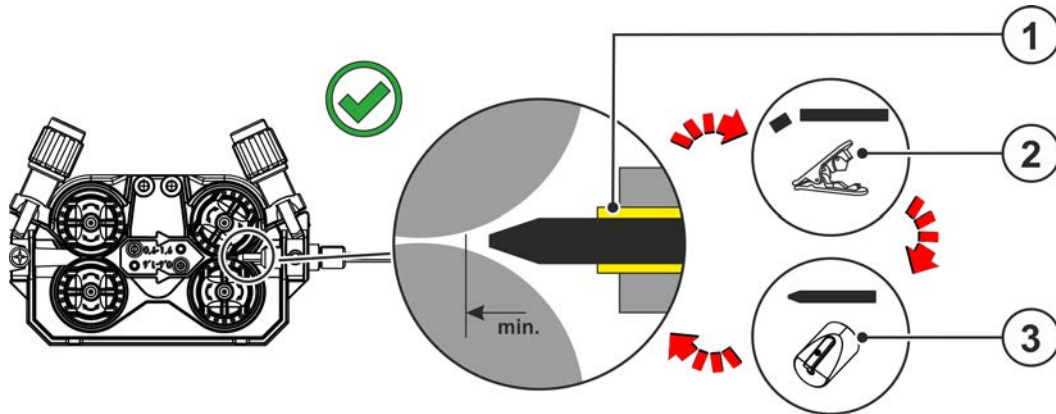

Figure 5-14

5.2.2 Welding torch connection

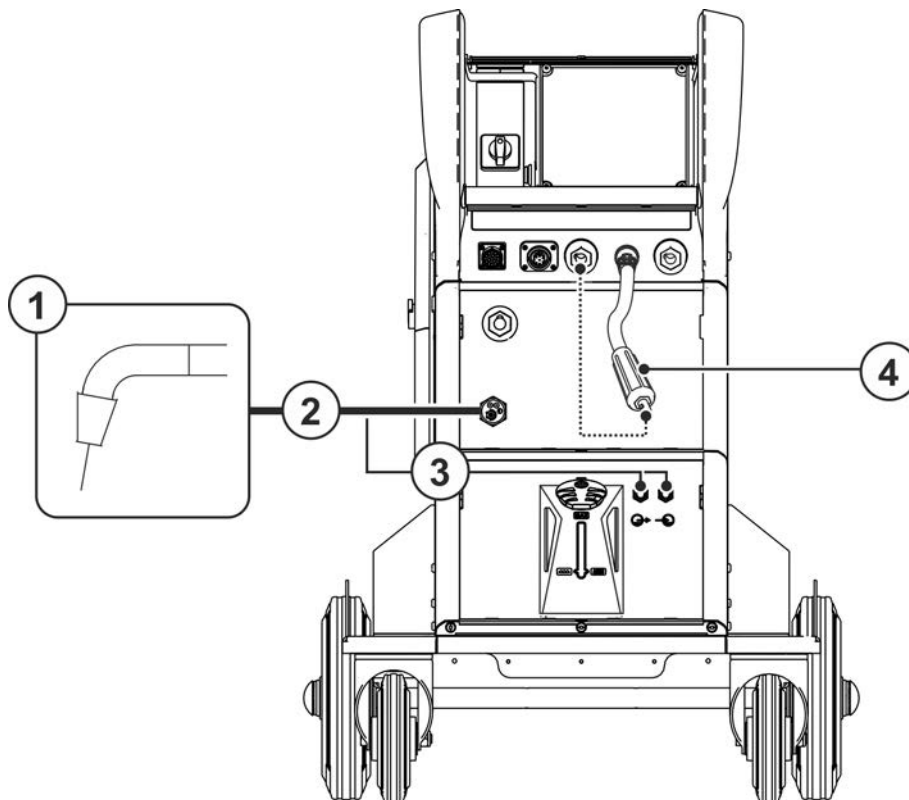

Figure 5-15

Item	Symbol	Description
1		Welding torch

Item	Symbol	Description
2		Welding torch hose package
3		Connection of coolant lines (welding torch) Quick connect couplings
4		Polarity selection plug, welding current cable > see 5.1.13 chapter

- Insert the polarity selection plug into the "+" welding current connection socket and lock in place by turning to the right.
- Insert the central plug for the welding torch into the central connector and screw together with crown nut.
- Lock connecting nipples of the cooling water tubes into the corresponding quick connect couplings: Return line red to quick connect coupling, red (coolant return) and supply line blue to quick connect coupling, blue (coolant supply).



Equipment damage due to improperly connected coolant pipes!

If the coolant pipes are not properly connected or a gas-cooled welding torch is used, the coolant circuit is interrupted and equipment damage can occur.

- **Connect all coolant pipes correctly!**
- **Completely unroll the hose package and the torch hose package!**
- **Observe maximal hose package length > see 5.1.5.3 chapter.**
- **When using a gas-cooled welding torch, use a hose bridge to establish the coolant circuit > see 9 chapter.**

5.2.3 Connection for workpiece lead

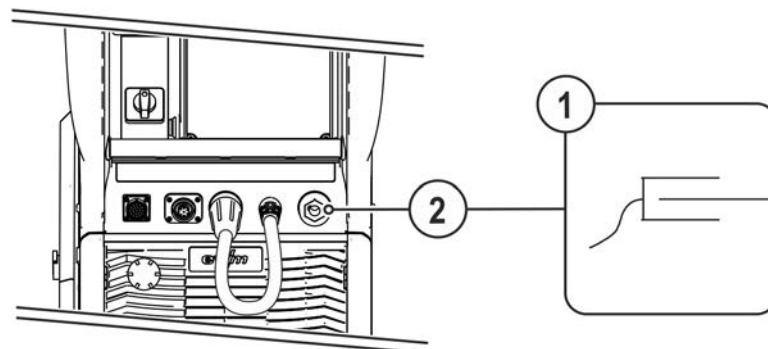

Figure 5-16

Item	Symbol	Description
1		Workpiece
2		Connection socket, "-" welding current Workpiece lead connection

- Insert the plug on the workpiece lead into the "-" welding current connection socket and lock.

Some wire electrodes (e.g. self-shielding cored wire) are welded using negative polarity. In this case, the welding current lead should be connected to the "-" welding current socket, and the workpiece lead should be connected to the "+" welding current socket. Observe the information from the electrode manufacturer!

5.2.4 Wire feed

⚠ CAUTION



Risk of injury due to moving parts!

The wire feeders are equipped with moving parts, which can trap hands, hair, clothing or tools and thus injure persons!

- Do not reach into rotating or moving parts or drive components!
- Keep casing covers or protective caps closed during operation!



Risk of injury due to welding wire escaping in an unpredictable manner!

Welding wire can be conveyed at very high speeds and, if conveyed incorrectly, may escape in an uncontrolled manner and injure persons!

- Before mains connection, set up the complete wire guide system from the wire spool to the welding torch!
- Check wire guide at regular intervals!
- Keep all casing covers or protective caps closed during operation!

5.2.4.1 Inserting the wire spool

⚠ CAUTION



Risk of injury due to incorrectly secured wire spool.

If the wire spool is not secured properly, it may come loose from the wire spool support and fall to the ground, causing damage to the machine and injuries.

- Make sure to correctly fasten the wire spool to the wire spool support.
- Before you start working, always check the wire spool is securely fastened.

Standard D300 wire spool holder can be used. Adapters are required when using standardised basket coils (DIN 8559) > see 9 chapter.

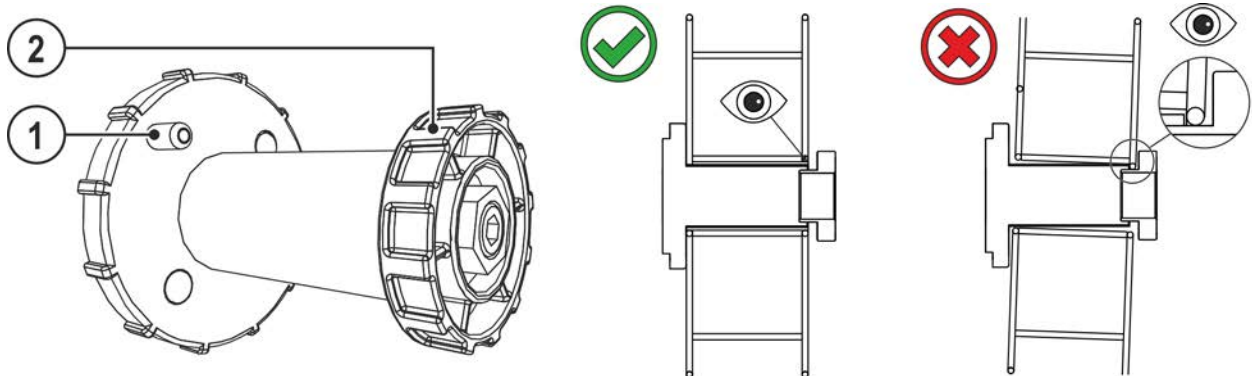

Figure 5-17

Item	Symbol	Description
1		Carrier pin For fixing the wire spool
2		Knurled nut For fixing the wire spool

- Unlock and open protective flap.
- Loosen knurled nut from spool holder.
- Fix welding wire reel onto the spool holder so that the carrier pin locks into the spool bore.
- Fasten wire spool using knurled nut.

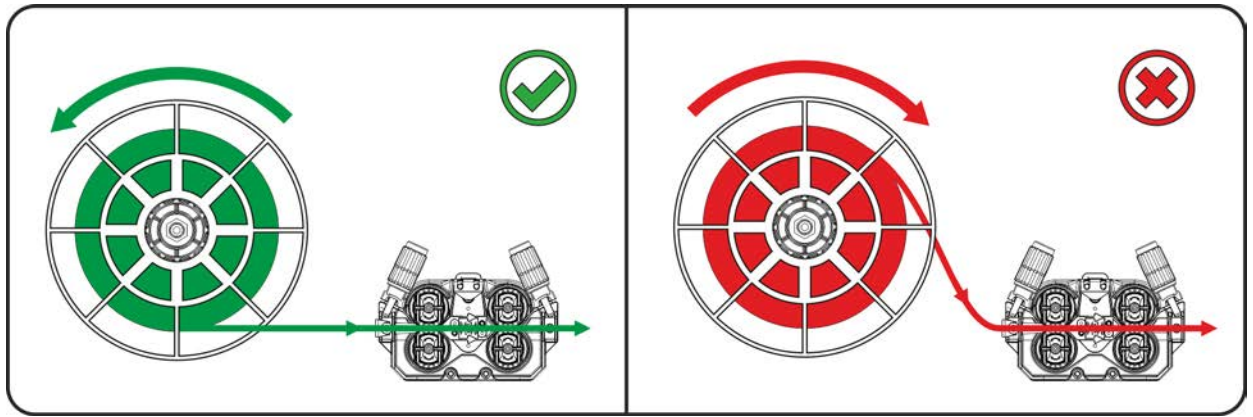

Figure 5-18

Observe the unwinding direction of the wire spool.

5.2.4.2 Changing the wire feed rollers

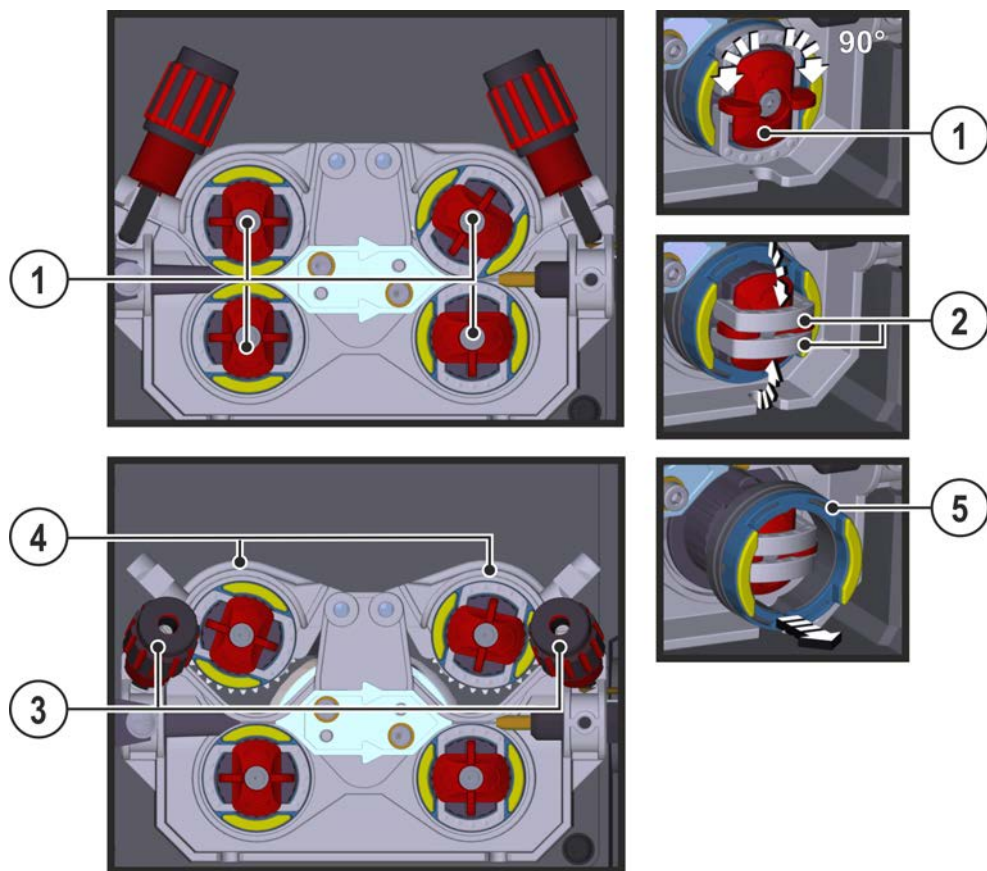

Figure 5-19

Item	Symbol	Description
1		Tommy The tommy is used to secure the closure brackets of the wire feed rollers.
2		Closure bracket The closure brackets are used to secure the wire feed rollers.
3		Feed roll tensioner Fixing the clamping unit and setting the pressure.
4		Clamping unit
5		Wire feed roller see the Wire feed roller overview table

- Rotate the tommy by 90° clockwise or anti-clockwise (tommy locks into place).
- Fold the closure brackets outwards by 90°.
- Unfasten pressure units and fold out (clamping units and pressure rollers will automatically flip upwards).
- Remove the wire feed rollers from the roller support.
- Select new wire feed rollers according to the Wire feed roller overview table and reassemble the wire feed mechanism in reverse order.

Unsatisfactory welding results due to faulty wire feeding!

The wire feed rolls must be suitable for the diameter of the wire and the material. The wire feed rolls are colour-coded to facilitate distinction (see the Wire feed roll overview table). When working with a wire diameter of > 1.6 mm the drive has to be converted for the wire feed kit ON WF 2,0-3,2MM EFEED > see 10 chapter.

Wire feed roll overview table:

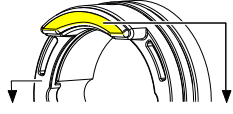
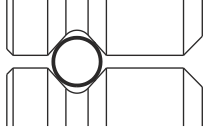
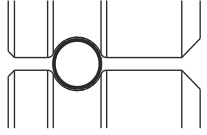
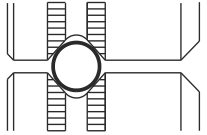
Material	Diameter		Colour code			Groove form
	Ø mm	Ø inch				
Steel Stainless steel Brazing	0.6	.024	monochrome	light pink	-	 V-groove
	0.8	.031		white		
	0.8	.031	bicolour	white	blue	
	0.9	.035				
	1.0	.039				
	1.0	.039		blue	red	
	1.2	.047				
	1.4	.055	monochrome	green	-	
	1.6	.063		black		
	2.0	.079		grey		
2.4	.094	brown				
2.8	.110	light green				
3.2	.126	purple				
Aluminium	0.8	.031	bicolour	white	yellow	 U-groove
	0.9	.035		blue		
	1.0	.039				
	1.2	.047		red		
	1.6	.063		black		
	2.0	.079		grey		
	2.4	.094		brown		
	2.8	.110		light green		
	3.2	.126		purple		
Flux cored wire	0.8	.031	bicolour	white	orange	 V-groove, knurled
	0.9	.035		blue		
	1.0	.039				
	1.2	.047		red		
	1.4	.055		green		
	1.6	.063		black		
	2.0	.079		grey		
	2.4	.094		brown		

5.2.4.3 Inching the wire electrode

⚠ CAUTION



Risk of injury due to welding wire escaping from the welding torch!

The welding wire can escape from the welding torch at high speed and cause bodily injury including injuries to the face and eyes!

- Never direct the welding torch towards your own body or towards other persons!



Improper contact pressure increases wear on the wire feed rolls.

Adjust the contact pressure on the adjusting nuts of the feed roll tensioners so that the wire electrode is fed but slips when the wire spool is blocked.

The inching speed is infinitely adjustable by simultaneously pressing the wire inching push-button and turning the wire speed rotary knob. The left display shows the wire feed speed selected, the right display shows the current motor current of the wire feed mechanism.

Depending on the design of the device, the wire feed mechanism may be reversed!

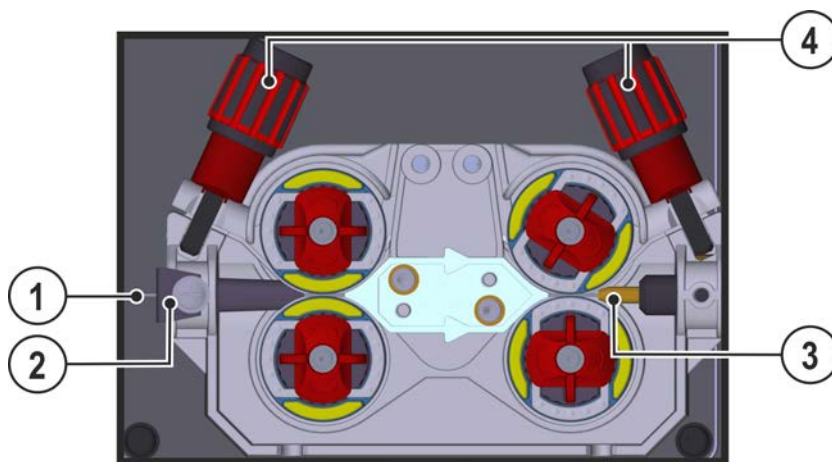

Figure 5-20

Item	Symbol	Description
1		Welding wire
2		Wire feed nipple
3		Guide tube
4		Adjusting nut

- Extend and lay out the torch hose package.
- Carefully unwind the welding wire from the wire spool and insert through the wire feed nipples up to the wire feed rollers.
- Press the inching push-button (the drive catches the welding wire and automatically guides it to the welding torch outlet) > see 4.4 chapter.

A prerequisite for the automatic inching process is the correct preparation of the wire guide, especially in the capillary and wire guide tube area > see 5.2.2 chapter.

- The contact pressure has to be adjusted separately for each side (wire inlet/outlet) at the feed roll tensioner setting nuts depending on the welding consumable used. A table with the setting values can be found on a sticker near the wire drive.

Version 1: left hand mounting

Version 2: right hand mounting

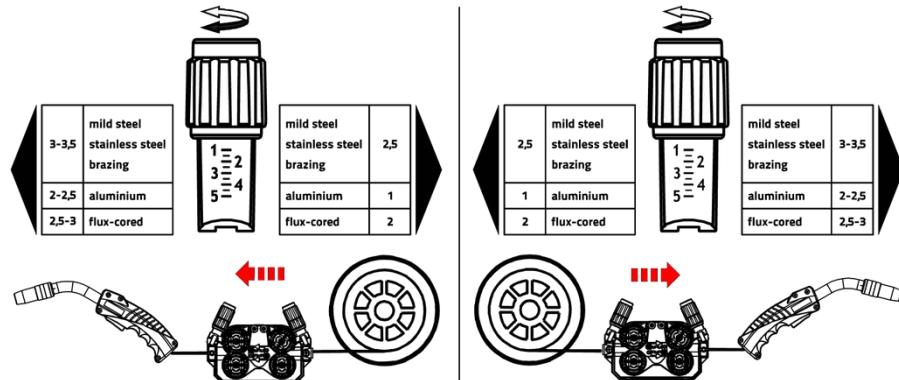

Figure 5-21

Automatic inching stop

Touch the welding torch against the workpiece during inching. Inching of the welding wire will stop as soon it touches the workpiece.

5.2.4.4 Spool brake setting

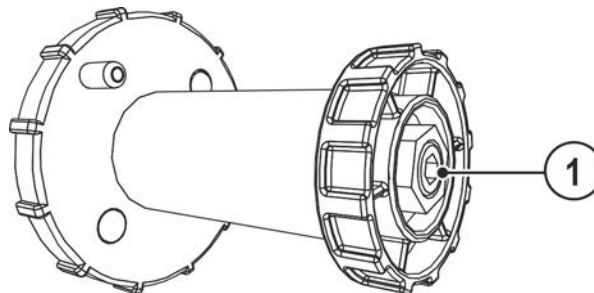

Figure 5-22

Item	Symbol	Description
1		Allen screw Securing the wire spool retainer and adjustment of the spool brake

- Tighten the Allen screw (8 mm) in the clockwise direction to increase the braking effect.

Tighten the spool brake until the wire spool no longer turns when the wire feed motor stops but without it jamming during operation!

5.2.5 Welding task selection

For selection of the welding task and for general operation see the relevant Control operating instructions.

5.3 TIG welding

5.3.1 Welding torch connection

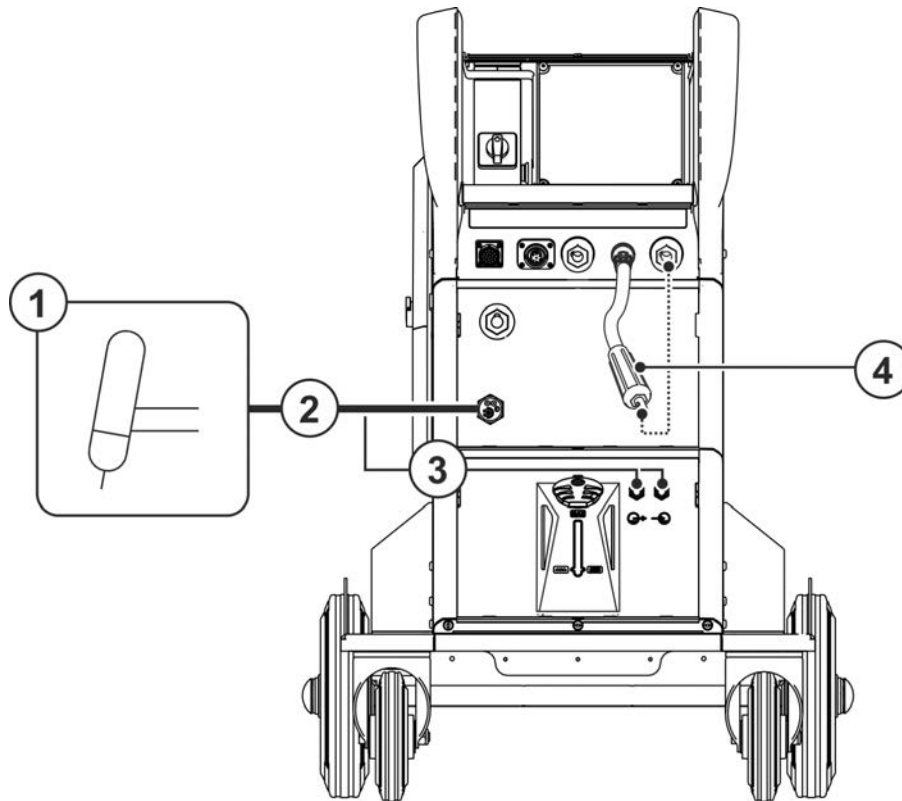

Figure 5-23

Item	Symbol	Description
1		Welding torch
2		Welding torch hose package
3		Connection of coolant lines (welding torch) Quick connect couplings
4		Polarity selection plug, welding current cable > see 5.1.13 chapter

- Insert the polarity selection plug into the "-" welding current connection socket and lock in place by turning to the right.
- Insert the central plug for the welding torch into the central connector and screw together with crown nut.
- Lock connecting nipples of the cooling water tubes into the corresponding quick connect couplings: Return line red to quick connect coupling, red (coolant return) and supply line blue to quick connect coupling, blue (coolant supply).

5.3.2 Connection for workpiece lead

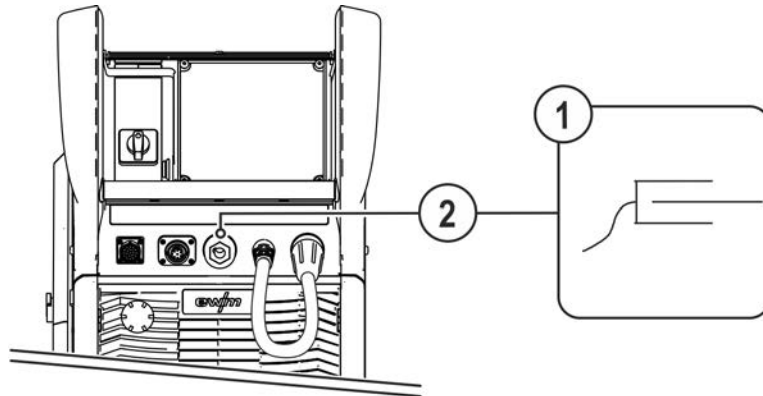

Figure 5-24

Item	Symbol	Description
1		Workpiece
2		Connection socket for "+" welding current Workpiece lead connection

- Insert the plug on the workpiece lead into the "-" welding current connection socket and lock. **Some wire electrodes (e.g. self-shielding cored wire) are welded using negative polarity. In this case, the welding current lead should be connected to the "-" welding current socket, and the workpiece lead should be connected to the "+" welding current socket. Observe the information from the electrode manufacturer!**

5.3.3 Welding task selection

For selection of the welding task and for general operation see the relevant Control operating instructions.

5.4 MMA welding

5.4.1 Connecting the electrode holder and workpiece lead

CAUTION



Risk of crushing and burns!

When changing stick electrodes there is a risk of crushing and burns!

- Wear appropriate and dry protective gloves.
- Use an insulated pair of tongs to remove the used stick electrode or to move welded workpieces.

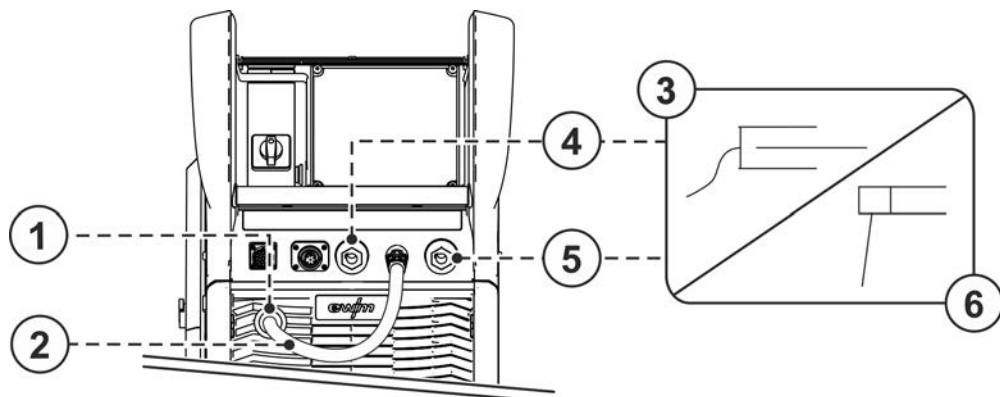





Figure 5-25

Item	Symbol	Description
1		Park socket, polarity selection plug Retainer for the polarity selection plug in MMA mode or for transport.

Item	Symbol	Description
2		Polarity selection plug, welding current cable > see 5.1.13 chapter
3		Workpiece
4		Connection socket, "+" welding current
5		Connection socket, welding current "-"
6		Electrode holder

- Insert the polarity selection plug in the park socket and lock in place by turning to the right.
- Insert the electrode holder plug and workpiece lead into the welding current socket depending on application and lock in place by turning to the right. The corresponding polarity will be based on the information of the electrode manufacturer on the electrode packaging.

5.4.2 Welding task selection

For selection of the welding task and for general operation see the relevant Control operating instructions.

5.5 Remote control

The remote controls are operated via the 19-pole remote control connection socket (analogue) or the 7-pole remote control connection socket (digital), depending on the model.

Read and observe the documentation to all system and accessory components!

5.6 Access control

For selection of the welding task and for general operation see the relevant Control operating instructions.

5.7 Interfaces for automation

⚠ WARNING



No improper repairs and modifications!

To prevent injuries and damage to the machine, only competent personnel (authorised service personnel) are allowed to repair or modify the machine.

Unauthorised manipulations will invalidate the warranty!

- Instruct competent personnel (authorised service personnel) to repair the machine.



Unsuitable control cables or incorrect input/output signal assignment can cause damage to the machine. Use shielded control cables only.

5.7.1 Automation interface

⚠ WARNING



No function of the external interrupt equipment (emergency stop switch)!

If the emergency stop circuit has been set up using an external interrupt equipment connected to the interface for automated welding, the machine must be configured for this setup. If this is not observed, the power source will ignore the external interrupt equipment and will not shut down!

- Remove jumper 1 on the corresponding control board (to be done only by qualified service personnel)!

These accessory components can be retrofitted as an option > see 9 chapter.

Pin	Input / Output	Name	Figure
A	Output	PE ----- Connection for cable screen	
D	Output (open collector)	IGRO---- Current flows signal I>0 (maximum load 20 mA / 15 V) 0 V = welding current flows	
E/R	Input	Not-Aus- Emergency stop for higher level shut-down of the power source.	
F	Output	0V----- Reference potential	
G/P	Output	IGRO---- Current relay contact to the user, potential-free (max. +/-15 V / 100 mA)	
H	Output	Uist ----- Welding voltage measured against pin F, 0-10 V (0 V = 0 V; 10 V = 100 V) ^[1]	
L	Input	STA/STP Start = 15 V / Stop = 0 V ^[2]	
M	Output	+15 V---- Power supply (max. 75 mA)	
N	Output	-15 V ---- Power supply (max. 25 mA)	
S	Output	0 V----- Reference potential	
T	Output	list----- Welding current measured against pin F; 0-10 V (0 V = 0 A, 10 V = 1000 A) ^[3]	

^[1] Accuracy type $\pm (0.05 \text{ V} + 2.5 \% \text{ of the measured value})$

^[2] The operating mode is specified by the wire feeder (the start / stop function corresponds to the operation of the torch trigger and is used, for instance, in mechanized applications).

^[3] Accuracy type $\pm (0.02 \text{ V} + 2.5 \% \text{ of the measured value})$

5.7.2 RINT X12 robot interface

The standard digital interface for mechanised applications

Functions and signals:

- Digital inputs: start/stop, operating modes, JOB and program selection, inching, gas test
- Analogue inputs: control voltages, e.g. for welding performance, welding current, etc.
- Relay outputs: process signal, ready for welding, system composite fault, etc.

5.7.3 BUSINT X11 industrial bus interface

The solution for easy integration with automated production with e.g.

- Profinet/Profibus
- EnthernetIP/DeviceNet
- EtherCAT

etc.

5.8 PC interface

Welding parameter software

Set all welding parameters on the PC and simply transfer to one or more welding machines (accessory, set consisting of software, interface, connection leads)

- Data exchange between power source and PC
- Welding task administration (JOBS)
- Online-data exchange
- Default settings for welding data monitoring
- Update function for new welding parameters

5.8.1 Connection



Equipment damage or faults may occur if the PC is connected incorrectly!

Not using the SECINT X10USB interface results in equipment damage or faults in signal transmission. The PC may be destroyed due to high frequency ignition pulses.

- **Interface SECINT X10USB must be connected between the PC and the welding machine!**
- **The connection must only be made using the cables supplied (do not use any additional extension cables)!**

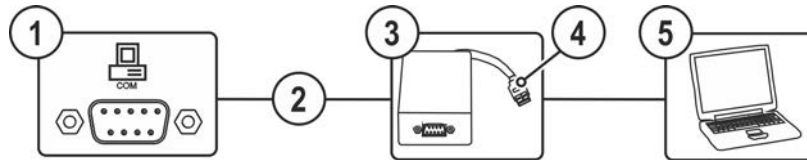

Figure 5-26

Item	Symbol	Description
1		Connection socket (9-pole) - D-Sub PC interface
2		Connection cable, 9-pole, serial
3		SECINT X10 USB
4		USB connection Connecting a Windows PC to SECINT X10 USB
5		Windows PC

5.9 Component identification

Only together with the device control Expert XQ 2.0 in the LAN gateway or LAN/Wi-Fi gateway version.

Bar codes predefined in ewm Xnet are recorded with a manual scanner. Component data are retrieved and displayed in the control.

These accessory components can be retrofitted as an option > see 9 chapter.

5.10 Network connection

This accessory component is only available as a “factory-fit option”.

The network connection allows the integration of the product into an existing network and exchanging data using the quality-management software Xnet. Some features of the software:

- Real-time display of the welding parameters
- Recording / documentation
- Monitoring of welding parameters
- Maintenance
- Calculations
- WPS management
- Welder management
- xButton management
- Component management

The functionality of the software is in constant development (see the documentation for Xnet).

As standard, welding machines are supplied with a fixed IP address.

Depending on the machine version, the IP address is displayed in the device control or shown on a sticker either below the rating plate or near the control.

The gateway and the server / computer must be in the same network or IP address range to allow the configuration of the gateway.

6 Maintenance, care and disposal

6.1 General

WARNING



Improper maintenance, testing and repairs!

Maintenance, testing and repair of the machine may only be carried out by skilled and qualified personnel (authorised service personnel). A competent person is someone who, based on training, knowledge and experience, can recognize the hazards and possible consequential damage that may occur when testing power sources and can take the necessary safety precautions.

- Follow the maintenance instructions > see 6.3 chapter.
- If any of the test requirements below are not met, the unit must not be put back into operation until it has been repaired and tested again.

As a rule, contact your specialised dealer, i.e. the supplier of the machine, with respect to all servicing matters. Any return deliveries in the case of warranty claims can be made via your specialised dealer only.

Only use original spare parts to replace any part. When ordering a spare part, always specify the type, serial number and article number of the machine, and the type designation and article number of the spare part.

Under the specified ambient conditions and normal working conditions this machine is essentially maintenance-free and requires just a minimum of care.

Contamination of the machine may impair service life and duty cycle. The cleaning intervals depend on the ambient conditions and the resulting contamination of the machine. The minimum interval is every six months.

6.2 Explanation of icons

Personnel

	Welder / operator
	Qualified person (authorised service personnel)

Tests

	Visual inspection
	Functional test

Period, interval

	One-shift operation
	Multi-shift operation
	Every 8 hours
	Daily
	Weekly
	Monthly
	Every 6 months
	Annually

6.3 Maintenance schedule

Inspector	Type of inspection			Maintenance step	Repairer
				! Only personnel designated as inspectors or repairers due to their training are allowed to carry out the relevant work step! Non-applicable inspection points are omitted.	
				<ul style="list-style-type: none"> Check and clean the welding torch. Deposits in the welding torch may cause short circuits, impair the welding result and lead to welding torch damage! Check wire drive, welding torches, and liner elements for application-related equipment and setting. Clean the wire feed rolls on a regular basis (depending on the degree of soiling). Replace worn wire feed rolls. Connections of the welding current leads (check for tight and locked seating). Is shielding gas cylinder with gas cylinder securing elements (chain/belt) secured? Strain relief: Are hose packages secured with strain relief? 	
				<ul style="list-style-type: none"> Checking all supply lines and their connections (pipes, hoses, hose packages) for damage or leaks. Checking the welding system for damage to the housing. 	

Inspector	Type of inspection	8h	24h	Maintenance step	Repairer
				<p>! Only personnel designated as inspectors or repairers due to their training are allowed to carry out the relevant work step! Non-applicable inspection points are omitted.</p>	
				<ul style="list-style-type: none"> Transport elements (strap, lifting eyes, handle, wheels, parking brake) corresponding safety elements (if necessary fuse caps) are present and flawless? 	
				<ul style="list-style-type: none"> Cleaning connections of coolant pipes (quick connect coupling, connections) from impurities and install protective caps when not in use. Gas test that the solenoid valve opens and closes properly. Checking operating, signalling and indicator lights, protective devices and actuators. 	
				<ul style="list-style-type: none"> Check wire feed roll holder (wire feed rolls must be firmly seated on their holders and must not have any play) Cleaning dirt filter (if applicable) > see 6.3.1 chapter 	
				<ul style="list-style-type: none"> Checking correct mounting of the wire spool. 	
				<ul style="list-style-type: none"> Clean external surfaces with a damp cloth (do not use aggressive cleaning agents). 	
				<ul style="list-style-type: none"> Cleaning the power source (inverter) > see 6.3.4 chapter 	
				<ul style="list-style-type: none"> Cleaning heat exchanger (torch cooling) > see 6.3.3 chapter 	
				<ul style="list-style-type: none"> Coolant change (torch cooling) > see 6.3.2 chapter 	
				<ul style="list-style-type: none"> Periodic inspection and testing > see 6.3.5 chapter 	
				<ul style="list-style-type: none"> The coolant must be checked using the appropriate frost protection tester TYP 1 (KF) or FSP (blueCool) for sufficient frost protection and replaced if necessary (accessories). 	

6.3.1 Dirt filter

When using a dirt filter, the cooling air throughput is reduced and the duty cycle of the machine is reduced as a result. The duty cycle decreases with the increasing contamination of the filter. The dirt filter must be removed at regular intervals and cleaned by blowing out with compressed air (depending on the level of soiling).

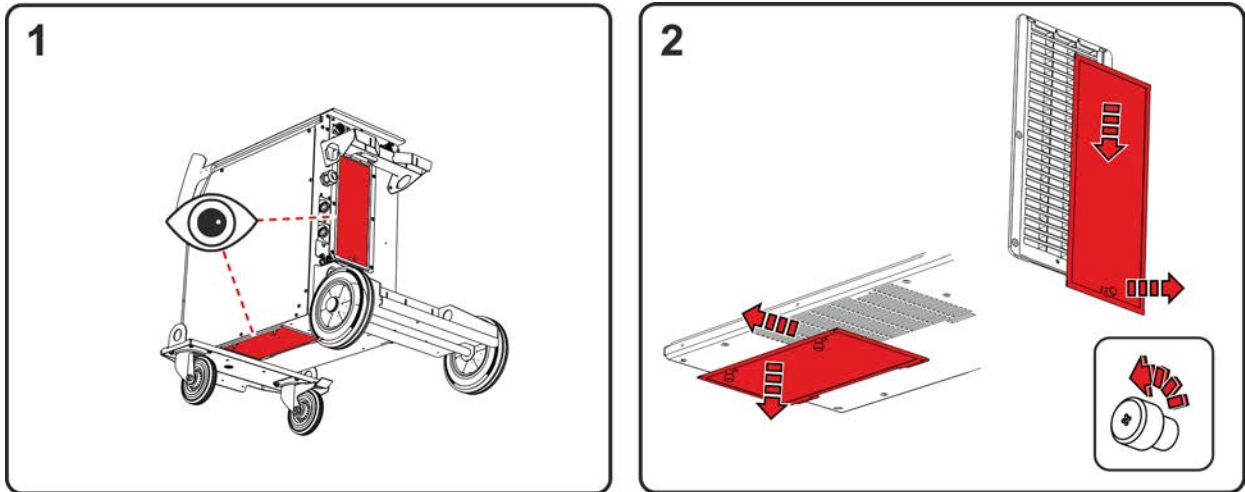

Figure 6-1

- Two dirt filters (option for retrofitting) can be installed on the machine. One at the air inlet of the power unit (inverter) and one at the air inlet of the heat exchanger (torch cooling).
- Loosen the locking screws of the filters (pull the filter of the power unit downwards and then backwards and the filter of the heat exchanger downwards and then to the side).

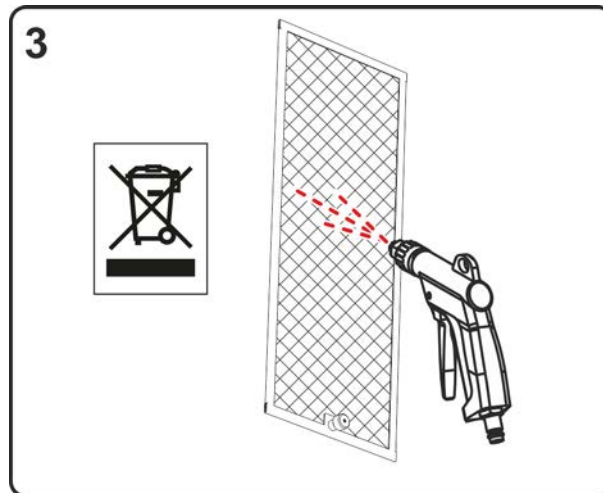

Figure 6-2

- Blow out the dirt filter with compressed air free of oil and water.

Follow official regulations on disposal!

- After cleaning, refit the filters in reverse order.

6.3.2 Coolant error

Observe all instructions for handling, use and disposal of torch coolant > see 5.1.5 chapter.

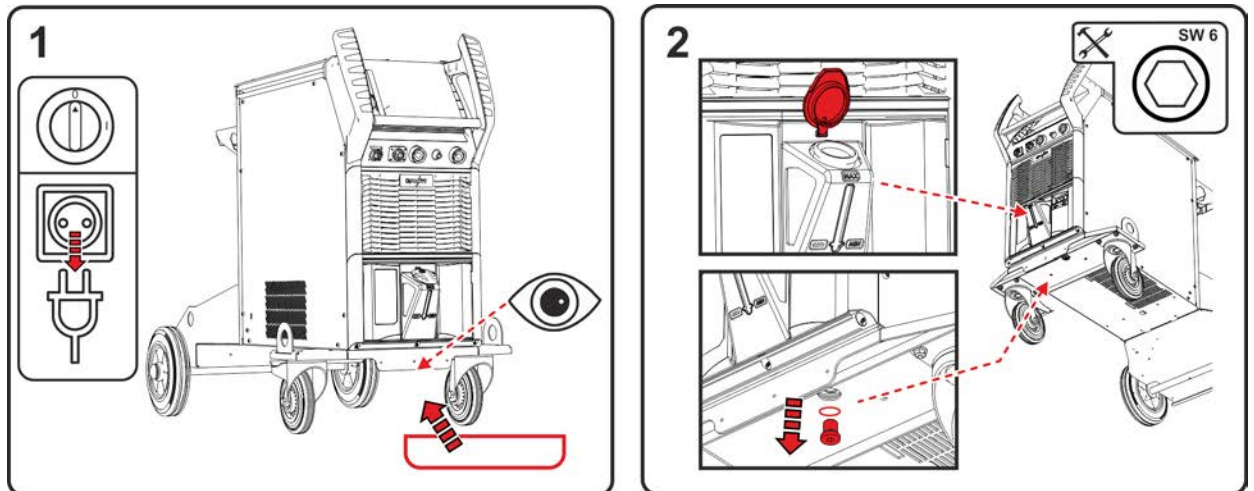

Figure 6-3

- Switch off the machine and disconnect the mains plug. Position a suitable collecting container under the drain plug of the coolant tank.
- Unscrew the drain plug of the coolant tank (remove the tank cap to ventilate).

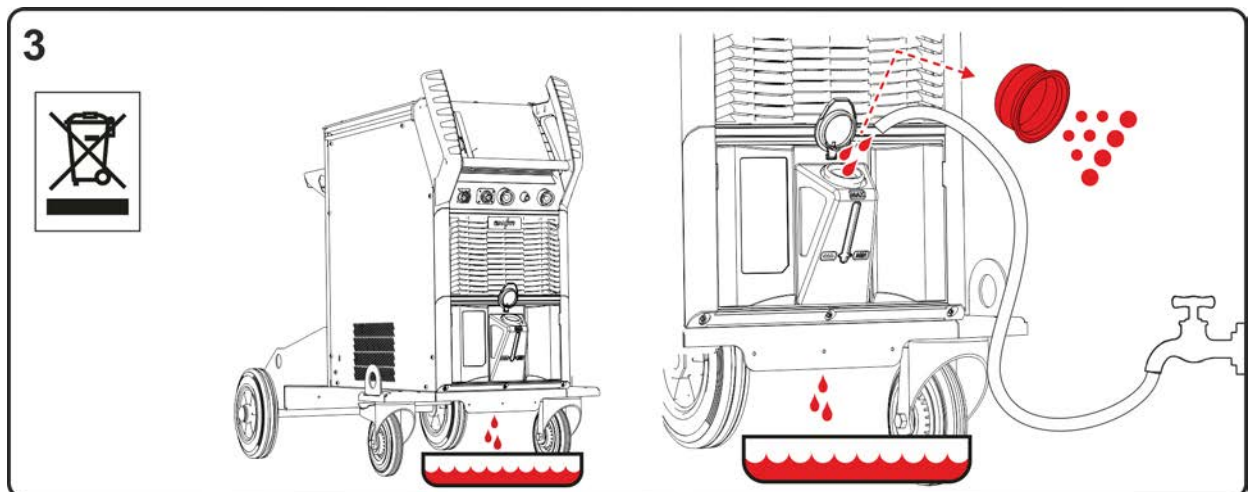

Figure 6-4

- Wait until the coolant has run out of the tank into the collection container.
- Remove the filter screen from the filler neck and clean.
- Then rinse the dirt out of the tank with water.

Follow official regulations on disposal!

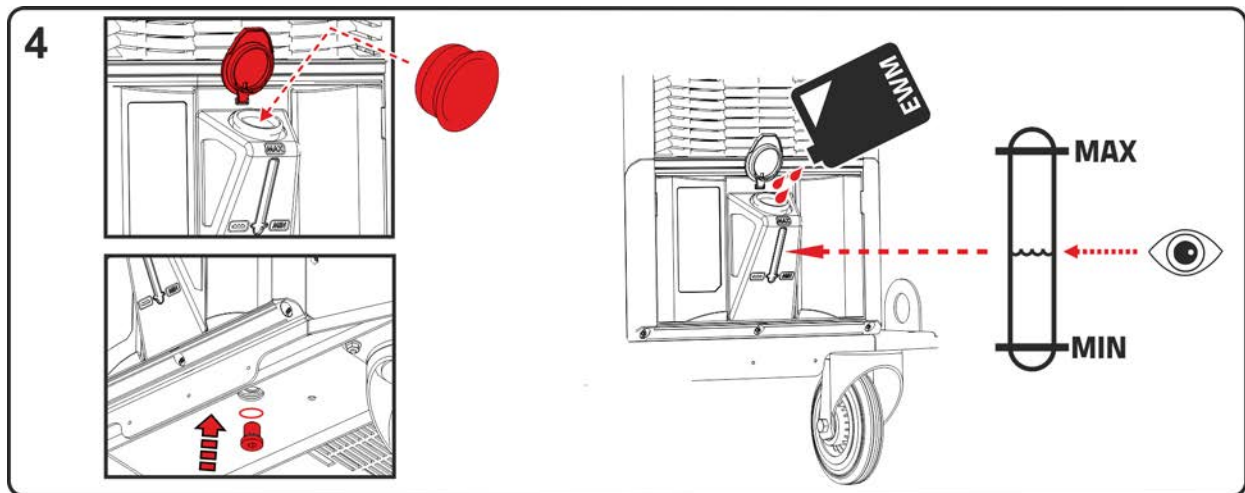

Figure 6-5

- Insert the cleaned filter screen into the filler neck and screw the drain plug with seal back into the tank.
- Fill the tank with original EWM coolant up to the maximum level. After filling, refit the tank cap and vent the coolant circuit > see 7.4 chapter.

6.3.3 Heat exchanger (torch cooling)

⚠ WARNING



Risk of injury due to insufficient training!

Appropriate training is required for the following maintenance steps to prevent injuries.

- Only authorised service personnel may carry out this maintenance step.
- Note the warnings and maintenance instructions at the beginning of this chapter!

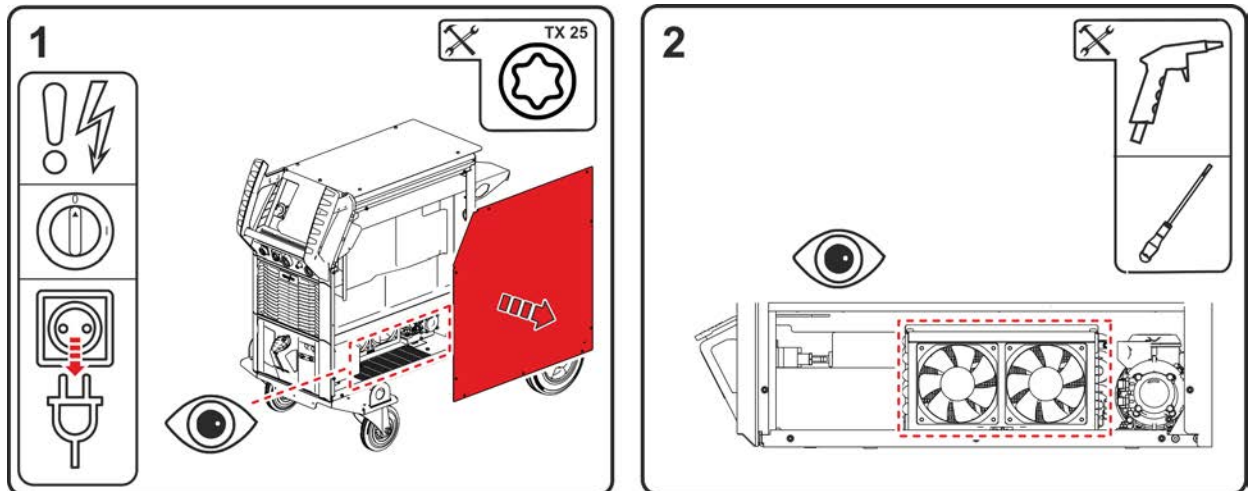

Figure 6-6

- Switch off the machine and disconnect the mains plug. Remove the screws of the side panel. Remove the side panel from the system (lift up and sideways).
- Use only compressed air free of water and oil. Do not blow on electronic components directly. The machine fans may over-rev due to the compressed air and thus become damaged. Therefore, use a screwdriver to block the machine fan mechanically. Please note: The strips of the heat exchanger behind the machine fans must not be damaged by the screwdriver.

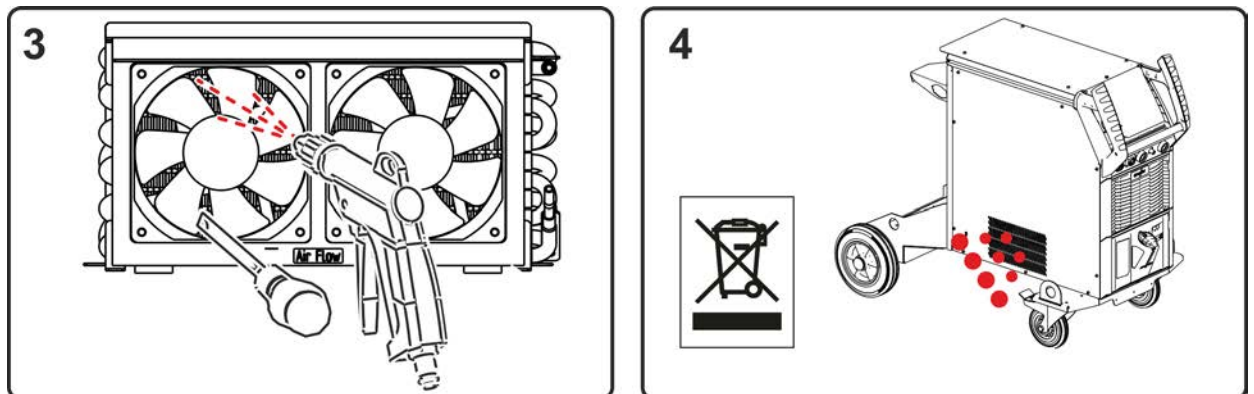

Figure 6-7

- Blow out the heat exchanger using the fans.
- The dirt escapes through the openings in the side panel.

Follow official regulations on disposal!

- After cleaning, remove any mechanical blockages from the fans, close the machine in reverse order and check according to applicable regulations.

6.3.4 Power source (inverter)

⚠ WARNING



Risk of injury due to insufficient training!

Appropriate training is required for the following maintenance steps to prevent injuries.

- Only authorised service personnel may carry out this maintenance step.
- Note the warnings and maintenance instructions at the beginning of this chapter!

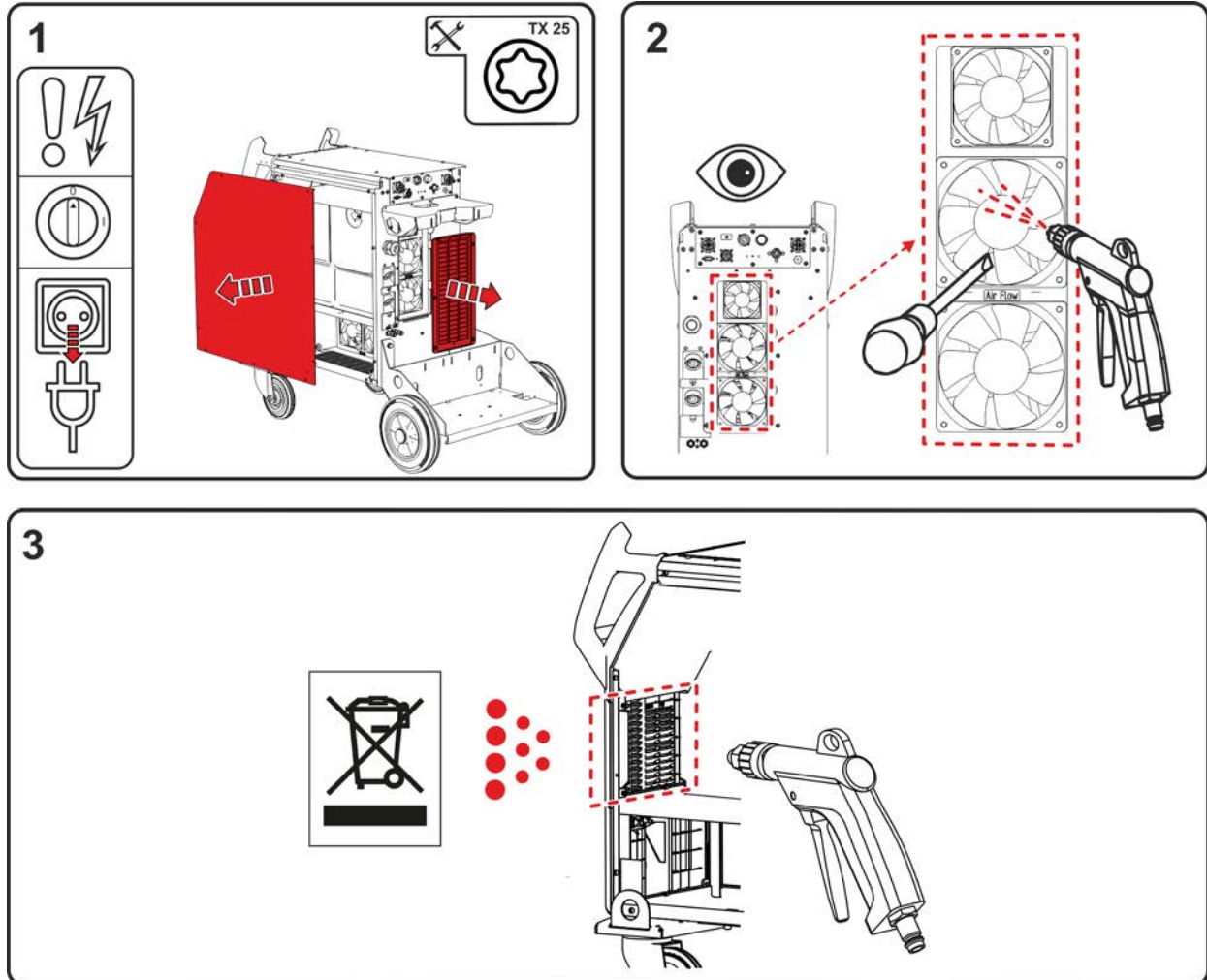

Figure 6-8

1. Switch off the machine and pull out the mains plug. Remove the screws of the side panel and the grille at the rear. Remove side panel (lift up and to the side). Remove grille (lift downwards and backwards).
2. Use only compressed air free of water and oil. Do not blow on electronic components directly. The machine fans can be overturned by to the compressed air and thus be damaged. Therefore mechanically block the machine fan with a screwdriver.
3. Blow out the areas in front of the inverter.

Observe local regulations on disposal!

- After cleaning, remove any mechanical blockages from the fans, close the machine in reverse order and check according to applicable regulations.

6.3.5 Annual test (inspection and testing during operation)

A periodic test according to IEC 60974-4 "Periodic inspection and test" has to be carried out. In addition to the regulations on testing given here, the relevant local laws and regulations must also be observed.

For more information refer to the "Warranty registration" brochure supplied and our information regarding warranty, maintenance and testing at www.ewm-group.com!

6.4 Disposing of equipment



Proper disposal!

The machine contains valuable raw materials, which should be recycled, and electronic components, which must be disposed of.

- **Do not dispose of in household waste!**
- **Observe the local regulations regarding disposal!**
- According to European provisions (Directive 2012/19/EU on Waste of Electrical and Electronic Equipment), used electric and electronic equipment may no longer be placed in unsorted municipal waste. It must be collected separately. The symbol depicting a waste container on wheels indicates that the equipment must be collected separately.
This machine has to be disposed of, or recycled, in accordance with the waste separation systems in use.

According to German law (law governing the distribution, taking back and environmentally correct disposal of electrical and electronic equipment (ElektroG)), used machines are to be placed in a collection system separate from unsorted municipal waste. The public waste management utilities (communities) have created collection points at which used equipment from private households can be disposed of free of charge.

The deletion of personal data is the responsibility of the end user.

Lamps, batteries or accumulators must be removed and disposed of separately before disposing of the device. The type of battery or accumulator and its composition is marked on the top (type CR2032 or SR44). The following EWM products may contain batteries or accumulators:

- **Welding helmets**
Batteries or accumulators are easy to remove from the LED cassette.
- **Device controls**
Batteries or accumulators are located on the back of these in corresponding sockets on the circuit board and are easy to remove. The controls can be removed using standard tools.

Information on returning used equipment or collections can be obtained from the respective municipal administration office. Devices can also be returned to EWM sales partners across Europe.

Further information on the topic of the disposal of electrical and electronic equipment can be found on our website at: <https://www.ewm-group.com/de/nachhaltigkeit.html>.



7 Rectifying faults

All products are subject to rigorous production checks and final checks. If, despite this, something fails to work at any time, please check the product using the following flowchart. If none of the fault rectification procedures described leads to the correct functioning of the product, please inform your authorised dealer.

7.1 Error messages (power source)

The possible error numbers displayed depend on the machine series and version!

Depending on the options of the machine display, a fault is shown as follows:

Display type - machine control	Display
Graphic display	
two 7-segment displays	
one 7-segment display	

The possible cause of the fault is signalled by a corresponding fault number (see table). In the case of an error, the power unit shuts down.

- Document machine errors and inform service staff as necessary.
- If multiple errors occur, these are displayed in succession.

Reset error (category legend)

^A The error message disappears when the error is eliminated.

^B The error message can be reset by pressing a push-button ◀.

All other error messages can only be reset by switching the machine off and on again.

Error 3: Tacho error

Category A, B

- ✓ Fault in the wire feeder.
 - ✘ Check the electrical connections (connectors, lines).
- ✓ Permanent overload of the wire drive.
 - ✘ Do not lay the liner in tight radii.
 - ✘ Check the liner for ease of movement.

Error 4: Excess temperature

Category A

- ✓ The power source is overheating.
 - ✘ Allow the switched-on machine to cool.
- ✓ Fan is blocked, dirty or defective.
 - ✘ Check the fan and clean or replace.
- ✓ Air inlet or outlet is blocked.
 - ✘ Check the air inlet and outlet.

Error 5: Mains overvoltage

- ✓ Mains voltage is too high.
 - ✘ Check the mains voltages and compare them with the connection voltages of the power source.

Error 6: Mains undervoltage

- ✓ Mains voltage is too low.
 - ✘ Check the mains voltages and compare them with the connection voltages of the power source.

Error 7: Low coolant level

Category B

- ✓ Low flow rate.
 - ✗ Fill with coolant.
 - ✗ Check coolant flow - remove kinks in the hose package.
 - ✗ Adjust the flow threshold ^[1].
 - ✗ Clean the cooler.
- ✓ Pump does not turn.
 - ✗ Turn the pump shaft.
- ✓ Air in the coolant circuit.
 - ✗ Vent the coolant circuit.
- ✓ The hose package is not filled with coolant.
 - ✗ Switch the machine off and on > pump running > filling process.
- ✓ Operation with a gas-cooled welding torch.
 - ✗ Deactivate the torch cooling.
 - ✗ Connect the coolant feed and return with a hose bridge.

Error 8: Shielding gas error

Category A, B

- ✓ No gas.
 - ✗ Check the gas supply.
- ✓ The pre-pressure is too low.
 - ✗ Remove kinks in the hose package (nominal value: 4-6 bar pre-pressure).

Error 9: Overvoltage on secondary

- ✓ Overvoltage at the output: Inverter error.
 - ✗ Request service.

Error 10: Earth fault (PE error)

- ✓ Connection between welding wire and machine casing.
 - ✗ Remove the electrical connection.
- ✓ Connection between welding circuit and machine casing.
 - ✗ Check the connection and routing of the earth wire / welding torch.

Error 11: Fast shutdown

Category A, B

- ✓ Remove the logical signal "Robot ready" during the process.
 - ✗ Eliminate errors on the higher-level control.

Error 16: Pilot-arc power source - collective error

Category A

- ✓ The external emergency stop circuit has been interrupted.
 - ✘ Check the emergency stop circuit and eliminate the cause of the error.
- ✓ The emergency stop circuit of the power source has been activated (internally configurable).
 - ✘ Deactivate the emergency stop circuit.
- ✓ The power source is overheating.
 - ✘ Allow the switched-on machine to cool.
- ✓ Fan is blocked, dirty or defective.
 - ✘ Check the fan and clean or replace.
- ✓ Air inlet or outlet is blocked.
 - ✘ Check the air inlet and outlet.
- ✓ Short circuit on welding torch.
 - ✘ Check the welding torch.
 - ✘ Request service.

Error 17: Cold wire error

Category B

- ✓ Fault in the wire feeder.
 - ✘ Check the electrical connections (connectors, lines).
- ✓ Permanent overload of the wire drive.
 - ✘ Do not lay the liner in tight radii.
 - ✘ Check the liner for smooth movement.

Error 18: Plasma gas error

Category B

- ✓ No gas.
 - ✘ Check the gas supply.
- ✓ The pre-pressure is too low.
 - ✘ Remove kinks in the hose package (nominal value: 4-6 bar pre-pressure).

Error 19: Shielding gas error

Category B

- ✓ No gas.
 - ✘ Check the gas supply.
- ✓ The pre-pressure is too low.
 - ✘ Remove kinks in the hose package (nominal value: 4-6 bar pre-pressure).

Error 20: Low coolant level

Category B

- ✓ Low flow rate.
 - ✗ Fill with coolant.
 - ✗ Check coolant flow - remove kinks in the hose package.
 - ✗ Adjust the flow threshold ^[1].
 - ✗ Clean the cooler.
- ✓ Pump does not turn.
 - ✗ Turn the pump shaft.
- ✓ Air in the coolant circuit.
 - ✗ Vent the coolant circuit.
- ✓ The hose package is not filled with coolant.
 - ✗ Switch the machine off and on > pump running > filling process.
- ✓ Operation with a gas-cooled welding torch.
 - ✗ Deactivate the torch cooling.
 - ✗ Connect the coolant feed and return with a hose bridge.

Error 22: Excess coolant temperature

Category B

- ✓ Coolant is overheating ^[1].
 - ✗ Allow the switched-on machine to cool.
- ✓ Fan is blocked, dirty or defective.
 - ✗ Check, clean or replace the fan.
- ✓ Air inlet or outlet is blocked.
 - ✗ Check the air inlet and outlet.

Error 23: Excess temperature of the HF choke

Category A

- ✓ External XF ignition unit is overheating.
 - ✗ Allow the switched-on machine to cool.

Error 24: Pilot-arc ignition error

Category B

- ✓ The pilot arc cannot ignite.
 - ✗ Check the welding torch equipment.

Error 25: Forming gas error

Category B

- ✓ No gas.
 - ✗ Check the gas supply.
- ✓ The pre-pressure is too low.
 - ✗ Remove kinks in the hose package (nominal value: 4-6 bar pre-pressure).

Error 26: Excess temperature of the pilot arc module

Category A

- ✓ The power source is overheating.
 - ✗ Allow the switched-on machine to cool.
- ✓ Fan is blocked, dirty or defective.
 - ✗ Check the fan and clean or replace.
- ✓ Air inlet or outlet is blocked.
 - ✗ Check the air inlet and outlet.

Error 32: Error I>0

- ✓ Current recording is faulty.
- ✘ Request service.

Error 33: Error UIST

- ✓ Voltage recording is faulty.
- ✘ Eliminate the short circuit in the welding circuit.
- ✘ Remove the external sensor voltage.
- ✘ Request service.

Error 34: Electronics error

- ✓ A/D channel error
- ✘ Switch the machine off and on.
- ✘ Request service.

Error 35: Electronics error

- ✓ Slope error
- ✘ Switch the machine off and on.
- ✘ Request service.

Error 36: [S] errors

- ✓ [S] conditions violated.
- ✘ Switch the machine off and on.
- ✘ Request service.

Error 37: Electronics error

- ✓ The power source is overheating.
- ✘ Allow the switched-on machine to cool.
- ✓ Fan is blocked, dirty or defective.
- ✘ Check the fan and clean or replace.
- ✓ Air inlet or outlet is blocked.
- ✘ Check the air inlet and outlet.

Error 38: Error IIST

- ✓ Short circuit in the welding circuit before welding.
- ✘ Eliminate the short circuit in the welding circuit.
- ✘ Request service.

Error 39: Electronics error

- ✓ Overvoltage on secondary
- ✘ Switch the machine off and on.
- ✘ Request service.

Error 40: Electronics error

- ✓ Error I>0
- ✘ Request service.

Error 47: Error in the data interface with radio transmission

Category B

- ✓ Connection error between welding machine and peripheral unit.
- ✘ Note the documentation for the data interface with radio transmission.

Error 48: Ignition error

Category B

- ✓ No ignition at process start (automated machines).
 - ✘ Check the wire feeding
 - ✘ Check the load cable connections in the welding circuit.
 - ✘ Clean corroded surfaces on the workpiece before welding if necessary.

Error 49: Arc interruption

Category B

- ✓ An arc interruption occurred during welding with an automated system.
 - ✘ Check the wire feeding.
 - ✘ Adjust the welding speed.

Error 50: Program number

Category B

- ✓ Internal error.
 - ✘ Request service.

Error 51: Emergency stop

Category A

- ✓ The external emergency stop circuit has been interrupted.
 - ✘ Check the emergency stop circuit and eliminate the cause of the error.
- ✓ The emergency stop circuit of the power source has been activated (internally configurable).
 - ✘ Deactivate the emergency stop circuit.

Error 52: No DV machine

- ✓ After switching on the automated system, no wire feeder (DV) was detected.
 - ✘ Check or connect the control cables of the wire feeders.
 - ✘ Check the identification number of the automated wire feeder (for 1DV: number 1, for 2DV: each a wire feeder with number 1 and a wire feeder with number 2).

Error 53: No wire feeder 2

Category B

- ✓ Wire feeder 2 was not detected.
 - ✘ Check the control cable connections.

Error 54: VRD errors

- ✓ Error in the open-circuit voltage reduction.
 - ✘ If necessary, disconnect the external machine from the welding circuit.
 - ✘ Request service.

Error 55: Excess current of the wire feeder

Category B

- ✓ Excess current detected in the wire feed mechanism.
 - ✘ Do not lay the liner in tight radii.
 - ✘ Check the liner for ease of movement.

Error 56: Mains phase failure

- ✓ One phase of the mains voltage has failed.
 - ✘ Check mains connection, mains plug and mains fuses.

Error 57: Slave tacho error

Category B

- ✓ Fault in the wire feeder (slave drive).
 - ✘ Check the connections (connectors, lines).
- ✓ Permanent overload of the wire drive (slave drive).
 - ✘ Do not lay the liner in tight radii.
 - ✘ Check the liner for smooth movement.

Error 58: Short circuit

Category B

- ✓ Short circuit in the welding circuit.
 - ✘ Eliminate the short circuit in the welding circuit.
 - ✘ Place the welding torch on an insulated surface.

Error 59: Incompatible machine

- ✓ A machine connected to the system is not compatible.
 - ✘ Disconnect the incompatible machine from the system.

Error 60: Incompatible software

- ✓ The software of a machine is not compatible.
 - ✘ Disconnect the incompatible machine from the system
 - ✘ Request service.

Error 61: Welding monitoring

- ✓ The actual value of a welding parameter is outside the specified tolerance range.
 - ✘ Maintain the tolerance ranges.
 - ✘ Adjust the welding parameters.

Error 62: System component

- ✓ The system component was not found.
 - ✘ Request service.

Error 63: Mains voltage error

- ✓ Operating and mains voltage are incompatible.
 - ✘ Check or adjust the operating and mains voltage.

[1] See technical data for values and other switching thresholds > see 8.3 chapter.

7.2 Warnings

Depending on the display options of the machine display, a warning message is displayed as follows:

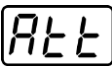
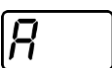
Display type - machine control	Display
Graphic display	
two 7-segment displays	
one 7-segment display	

The cause of the warning is indicated by a corresponding warning number (see table).

- In case of multiple warnings, these are displayed in sequence.
- Document machine warning and inform service personnel, if required.

Warning	Potential cause / remedy
1 Excess temperature	A shutdown is imminent due to excess temperature.

Warning		Potential cause / remedy
2	Half-wave failures	Check process parameters.
3	Torch cooling warning	Check coolant level and top up if necessary.
4	Shielding gas	Check shielding gas supply.
5	Coolant flow	Check min. flow rate. ^[2]
6	Wire reserve	Only a small amount of wire is left on the spool.
7	CAN bus failure	Wire feeder not connected; automatic circuit-breaker of wire feed motor (reset the tripped automatic circuit-breaker by actuating).
8	Welding circuit	The inductance of the welding circuit is too high for the selected welding task.
9	WF configuration	Check WF configuration.
10	Partial inverter	One of several partial inverters is not supplying welding current.
11	Excess temperature of the coolant ^[1]	Check temperature and switching thresholds. ^[2]
12	Welding monitoring	The actual value of a welding parameter is outside the specified tolerance field.
13	Contact error	The resistance in the welding circuit is too high. Check earth connection.
14	Alignment error	Switch the machine off and on. If the error persists, notify Service.
15	Mains fuse	The power limit of the mains fuse is reached and the welding power is reduced. Check the fuse setting.
16	Shielding gas warning	Check the gas supply.
17	Plasma gas warning	Check the gas supply.
18	Forming gas warning	Check the gas supply.
19	Gas warning 4	reserved
20	Coolant temperature warning	Check coolant level and top up if necessary.
21	Excess temperature 2	reserved
22	Excess temperature 3	reserved
23	Excess temperature 4	reserved
24	Coolant flow warning	Check coolant supply. Check coolant level and top up if necessary. Check flow and switching thresholds. ^[2]
25	Flow 2	reserved
26	Flow 3	reserved
27	Flow 4	reserved
28	Wire stock warning	Check wire feeding.
29	Low wire 2	reserved
30	Low wire 3	reserved
31	Low wire 4	reserved
32	Tacho error	Fault of wire feeder - permanent overload of the wire drive.
33	Excess current on the wire feed motor	Excess current detected on wire feed motor.

Warning	Potential cause / remedy
34 JOB unknown	JOB selection was not carried out because the JOB number is unknown.
35 Excess current on the wire feed motor slave	Excess current detected on wire feed motor slave (push/push system or intermediate drive).
36 Slave tacho error	Fault of wire feeder - permanent overload of the wire drive (push/push system or intermediate drive).
37 FAST bus failure	Wire feeder not connected (reset by actuating the automatic circuit-breaker of the wire feed motor).
38 Incomplete component information	Check the XNET component management.
39 Mains half-wave failure	Check supply voltage.
40 Weak power grid	Check supply voltage.
41 Cooling unit not recognised	Check the cooling unit connection.
47 Battery (remote control, type BT)	Battery level is low (replace battery)

^[1] only for the XQ machine series

^[2] See technical data for values and other switching thresholds > see 8.3 chapter.

7.3 Checklist for rectifying faults

The correct machine equipment for the material and process gas in use is a fundamental requirement for perfect operation!

Legend	Symbol	Description
	⚡	Fault/Cause
	⚡	Remedy

Functional errors

- ⚡ Mains fuse triggers - unsuitable mains fuse
 - ⚡ Set up recommended mains fuse > see 8.3 chapter.
- ⚡ Machine does not start up after switching on (device fan and possibly coolant pump have no function).
 - ⚡ Connect the control cable of the wire feeder.
- ⚡ All machine control signal lights are illuminated after switching on
- ⚡ No machine control signal light is illuminated after switching on
- ⚡ No welding power
 - ⚡ Phase failure > check mains connection (fuses)
- ⚡ Machine restarts continuously
- ⚡ Wire feeder without function
- ⚡ System does not start up
 - ⚡ Make control lead connections and check that they are fitted correctly.
- ⚡ Loose welding current connections
 - ⚡ Tighten power connections on the torch and/or on the workpiece
 - ⚡ Properly fasten the contact tip and contact tip holder.

Collective interference signal light illuminates

- ✓ Excess temperature, welding machine
 - ✘ Allow the machine to cool down whilst still switched on
- ✓ Welding current monitoring device triggered (stray welding currents flowing across the protective earth). The error must be reset by switching the machine off and on again.
 - ✘ Welding wire is touching electrically conductive casing parts (check wire guide, has the welding wire sprung off the wire spool?).
 - ✘ Check for a correct mounting of the welding lead. Fit the feeder clamp of the welding lead as close as possible to the arc.

Excess temperature signal light illuminates

- ✓ Excess temperature, welding machine
 - ✘ Allow the machine to cool down whilst still switched on

Coolant error/no coolant flowing

- ✓ Insufficient coolant flow
 - ✘ Check coolant level and refill if necessary
- ✓ Air in the coolant circuit
 - ✘ Vent coolant circuit > see 7.4 chapter

Wire feed problems

- ✓ Wire feed roll holder is worn (wire feed rolls must be firmly seated on their holders and must not have any play)
 - ✘ Replace wire feed roll holder (092-002960-E0000) > see 10.1.4 chapter
- ✓ Contact tip blocked
 - ✘ Clean and, if necessary, replace.
- ✓ Setting the spool brake > see 5.2.4.4 chapter
 - ✘ Check settings and correct if necessary
- ✓ Setting pressure units > see 5.2.4.3 chapter
 - ✘ Check settings and correct if necessary
- ✓ Worn wire rolls
 - ✘ Check and replace if necessary
- ✓ Wire feed motor without supply voltage (automatic cutout triggered by overloading)
 - ✘ Reset triggered fuse (rear of the power source) by pressing the key button
- ✓ Kinked hose packages
 - ✘ Extend and lay out the torch hose package
- ✓ Wire guide core or spiral is dirty or worn
 - ✘ Clean core or spiral; replace kinked or worn cores

7.4 Vent coolant circuit

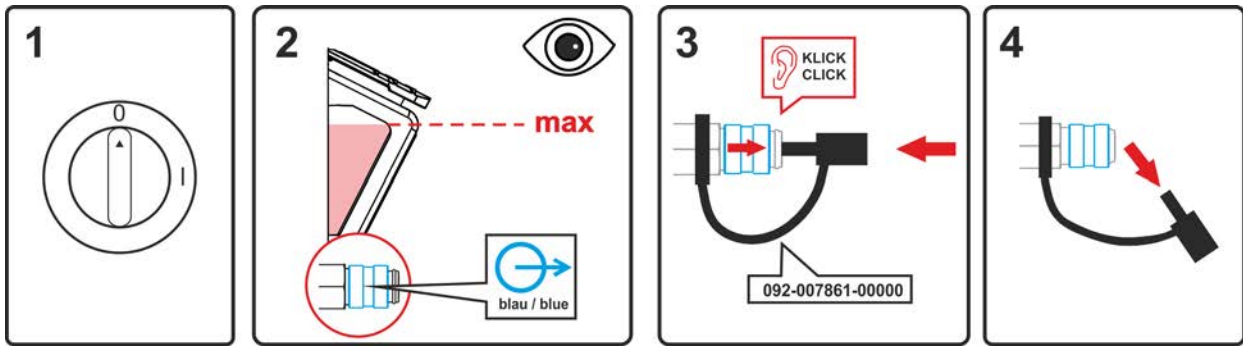

Figure 7-1

- Switch off the machine and fill the coolant tank to the maximum level.
- Unlock the quick-connect coupling with a suitable tool (connection open).

To vent the cooling system always use the blue coolant connection, which is located as deep as possible inside the system (close to the coolant tank)!

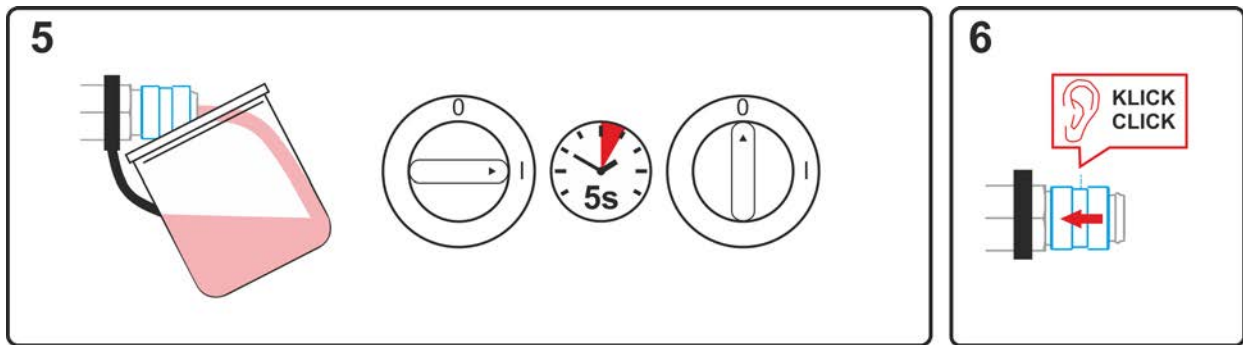

Figure 7-2

- Position a suitable collection container for collecting the escaping coolant at the quick-connect coupling and switch on the machine for approx. 5s.
- Lock the quick-connect coupling by pushing back the locking ring.

7.5 Fixing the pump shaft (coolant circuit)

Continuing non-use and impurities in the coolant may result in the the coolant pump not being in proper working order.

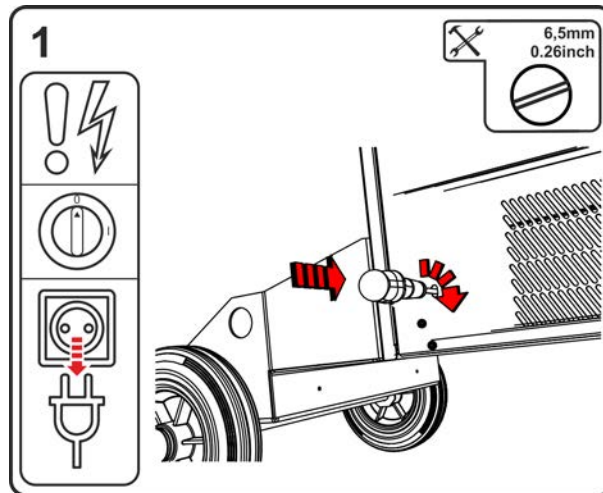

Figure 7-3

- Switch off machine at the main switch.
- Disconnect mains plug.
- Insert a plain slot screwdriver with a maximum tip width of 6.5 mm through the maintenance opening and place in the centre of the pump shaft. Turn the screwdriver clockwise until the pump shaft can be easily rotated again.
- Remove screwdriver.
- Insert mains plug of the switched-off machine into the appropriate socket.
- Switch on the power source at the main switch.

8 Technical data

Performance specifications and guarantee only in connection with original spare and replacement parts!

8.1 Dimensions and weights

		F06R1/R2		F06RS		F06P	
Dimensions (l x b x h)		mm	inch	mm	inch	mm	inch
l		1152	45.3	854	33.6	854	33.6
b		686	27.0	590	23.2	400	15.7
h		976	38.4	976	38.4	881	34.7
Weight ^[1]		kg	lb.	kg	lb.	kg	lb.
F06G		113	249.1	102,8	226.6	87,6	193.1
F06W		128	282.2	117,8	259.7	102,6	226.2

^[1] All weights refer to 5 m (16.4 ft.) machine versions Mains connection cable. For versions with longer mains connection cables, the weights increase.

10 m (32.8 ft.) = +2.5 kg (5.5 lb.)

15 m (49.2 ft.) = +5.0 kg (11.0 lb.)





8.2 Welding torch cooling system

Torch cooling	F06W
Cooling capacity at 1 l/min (+25°C/77°F)	1,5 kW
max. Flow rate	5 l/min 1.3 gal./min
max. Delivery height	35 m 115 ft.
max. Pump pressure	3,5 bar 0.35 MPa
Pump	Centrifugal pump
max. Tank content	8 l 2.1 gal.
Flow monitoring Error limit Warning limit ^[1]	0,7 l/min / 0.18 gal./min Offset +0,3 l/min / Offset +0.08 gal./min
Temperature monitoring Error limit Warning limit ^[1]	70°C / 158°F Offset -5°C / Offset -9°F

^[1] Offset from the set error limit

8.3 Performance data

8.3.1 Taurus XQ 350 Synergic C

	MIG/MAG	MMA	TIG
Welding current (I ₂)	5 A to 350 A		
Welding voltage according to standard (U ₂)	14,3 V to 31,5 V	20,2 V to 34,0 V	10,2 V to 24,0 V
Duty cycle DC at 40° C ^[1]	350 A (80 %) / 320 A (100%)		
Mains voltage	3 x 380-400 V / 3 x 440-460 V / 3 x 480-500 V		
Tolerance / mains fuse ^[2] / Frequency	-25 % to +20 % / 3 x 25 A / 50/60 Hz (380-400 V)		
	-25 % to +15 % / 3 x 20 A / 50/60 Hz (440-460 V)		
	-25 % to +10 % / 3 x 20 A / 50/60 Hz (480-500 V)		
Open circuit voltage (U ₀)	82 V (380-400 V)		
	94 V (440-460 V)		
	102 V (480-500 V)		
max. Connected load (S ₁)			
gas cooled (F06G)	13,9 kVA	15,1 kVA	10,6 kVA
water cooled (F06W)	14,3 kVA		11,0 kVA
Generator rating (Rec.)	20,4 kVA		
Power consumption P ₁ ^[3]	32 W		
Maximum mains impedance (@PCC)	107 mOhm		
Cos φ / efficiency	0,99 / 90 %		
Protection class / Overvoltage category	I / III		
Contamination level / Insulation class	3 / H		
protection classification / Residual current circuit breaker	IP 23 / Type B (recommended)		
Noise level ^[4]	<70 dB(A)		
Ambient temperature ^[5]	-25 °C to +40 °C		
Machine cooling / Torch cooling	Fan (AF) / gas or water		
Mains connection cable	H07RN-F4G6		
Workpiece lead (min.) / EMC class	70 mm ² / A		
Wire feed speed	0,5 m/min to 25m/min		
Factory-installed roll equipment / Drive	1,0-1,2 mm for steel wire / 4 rollers (37 mm)		
Wire spool diameter	Standardised wire spools up to 300 mm		
Welding torch connection	Euro torch connector		
Test mark	 /  /  / 		
Standards used	See declaration of conformity (appliance documents)		

^[1] Load cycle: 10 min. (60 % DC \triangleq 6 min. welding, 4 min. pause)





^[2] Safety fuses are recommended DIAZED xxA gG. When using automatic cutouts, the "C" trigger characteristic must be used.

^[3] Power in idle mode without wire feeder.

^[4] Noise level during idle mode and operation under standard load according to IEC 60974-1 at the maximum operating point.

^[5] Ambient temperature dependent on coolant! Observe coolant temperature range!

8.3.2 Taurus XQ 400 Synergic C

	MIG/MAG	MMA	TIG
Welding current (I ₂)	5 A to 400 A		
Welding voltage according to standard (U ₂)	14,3 V to 34 V	20,2 V to 36,0 V	10,2 V to 26,0 V
Duty cycle DC at 40° C ^[1]	400 A (60 %) / 350 A (80 %) / 320 A 100 %		
Mains voltage	3 x 380-400 V / 3 x 440-460 V / 3 x 480-500 V		
Frequency	50/60 Hz		
Tolerance / mains fuse ^[2]	-25 % to +20 % / 3 x 25 A (380-400 V)		
	-25 % to +15 % / 3 x 20 A (440-460 V)		
	-25 % to +10 % / 3 x 20 A (480-500 V)		
Open circuit voltage (U ₀)	82 V (380-400 V)		
	94 V (440-460 V)		
	102 V (480-500 V)		
max. Connected load (S ₁)			
gas cooled (F06G)	17,2 kVA	18,2 kVA	13,2 kVA
water cooled (F06W)	17,5 kVA		13,5 kVA
Generator rating (Rec.)	24,6 kVA		
Power consumption P _i ^[3]	32 W		
Maximum mains impedance (@PCC)	120 mOhm		
Cos φ / efficiency	0,99 / 90 %		
Protection class / Overvoltage category	I / III		
Contamination level / Insulation class	3 / H		
protection classification / Residual current circuit breaker	IP 23 / Type B (recommended)		
Noise level ^[4]	<70 dB(A)		
Ambient temperature ^[5]	-25 °C to +40 °C		
Machine cooling / Torch cooling	Fan (AF) / gas or water		
Mains connection cable	H07RN-F4G6		
Workpiece lead (min.) / EMC class	70 mm ² / A		
Wire feed speed	0,5 m/min to 25m/min		
Factory-installed roll equipment / Drive	1,0-1,2 mm for steel wire / 4 rollers (37 mm)		
Wire spool diameter	Standardised wire spools up to 300 mm		
Welding torch connection	Euro torch connector		
Test mark	 /  /  / 		
Standards used	See declaration of conformity (appliance documents)		

^[1] Load cycle: 10 min. (60 % DC \triangleq 6 min. welding, 4 min. pause)

^[2] Safety fuses are recommended DIAZED xxA gG. When using automatic cutouts, the "C" trigger characteristic must be used.

^[3] Power in idle mode without wire feeder.

^[4] Noise level during idle mode and operation under standard load according to IEC 60974-1 at the maximum operating point.

^[5] Ambient temperature dependent on coolant! Observe coolant temperature range!

9 Accessories

Performance-dependent accessories like torches, workpiece leads, electrode holders or intermediate hose packages are available from your authorised dealer.

9.1 General accessories

Type	Designation	Item no.
32A 5POLE/CEE	Machine plug	094-000207-00000
KLF-L1-L2-L3-PE	Label of mains cable	094-023697-00000
DM 842 Ar/CO2 230bar 30l D	Pressure regulator with manometer	394-002910-00030
DSP	Sharpener for liner	094-010427-00000
Cutter	Hose cutter	094-016585-00000

9.2 Welding torch cooling system

Type	Designation	Item no.
HOSE BRIDGE UNI	Tube bridge	092-007843-00000

9.2.1 Coolant - type blueCool

Type	Designation	Item no.
blueCool -10 5 l	Coolant up to -10 °C (14 °F), 5 l	094-024141-00005
blueCool -10 25 l	Coolant up to -10 °C (14 °F), 25 l	094-024141-00025
blueCool -30 5 l	Coolant up to -30 °C (22 °F), 5 l	094-024142-00005
blueCool -30 25 l	Coolant up to -30 °C (22 °F), 25 l	094-024142-00025
FSP blueCool	Frost protection tester	094-026477-00000

9.2.2 Coolant - type KF

Type	Designation	Item no.
KF 23E-5	Coolant up to -10 °C (14 °F), 5 l	094-000530-00005
KF 23E-200	Coolant (-10 °C), 200 litres	094-000530-00001
KF 37E-5	Coolant up to -20 °C (4 °F), 5 l	094-006256-00005
KF 37E-200	Coolant (-20 °C), 200 l	094-006256-00001
TYP1	Frost protection tester	094-014499-00000

9.3 7-pole remote control

Type	Designation	Item no.
RC XQ Expert 2.0 2 m	Expert XQ 2.0 remote control	090-008824-00002
RC XQ Expert 2.0 5 m	Expert XQ 2.0 remote control	090-008824-00005
RC XQ Expert 2.0 10 m	Expert XQ 2.0 remote control	090-008824-00010
RC XQ Expert 2.0 15 m	Expert XQ 2.0 remote control	090-008824-00015

9.3.1 Extension cable

Type	Designation	Item no.
FRV 7POL 0.5 m	Extension/connecting cable	092-000201-00004
FRV 7POL 1 m	Extension/connecting cable	092-000201-00002
FRV 7POL 5 m	Extension/connecting cable	092-000201-00003
FRV 7POL 10 m	Extension/connecting cable	092-000201-00000
FRV 7POL 15M	Extension/connecting cable	092-000201-00005
FRV 7POL 20 m	Extension/connecting cable	092-000201-00001
FRV 7POL 25M	Extension/connecting cable	092-000201-00007

9.4 19-pole remote control

Type	Designation	Item no.
R10 19POL	Remote control	090-008087-00000
RG10 19POL 5M	Remote control to set the wire speed and welding voltage correction	090-008108-00000
R20 19POL	Program changeover remote control	090-008263-00000

9.4.1 Connection cables

Type	Designation	Item no.
RA5 19POL 5M	Remote control e.g. connection cable	092-001470-00005
RA10 19POL 10m	Remote control e.g. connection cable	092-001470-00010
RA20 19POL 20m	Remote control e.g. connection cable	092-001470-00020

9.4.2 Extension cable

Type	Designation	Item no.
RV5M19 19POLE 5M	Extension cable	092-000857-00000
RV5M19 19POL 10M	Extension cable	092-000857-00010
RV5M19 19POL 15M	Extension cable	092-000857-00015
RV5M19 19POL 20M	Extension cable	092-000857-00020

9.5 Options

Type	Designation	Item no.
ON Filter F06	Dirt filter for air inlet	092-003337-00000
ON Shock Protect F06	Ram protection	092-003334-00000
ON TS F06 R	Torch holder, right	092-003335-00000
ON TS F06 L	Torch holder, left	092-003360-00000
ON SH F06 L	Scanner holder, left	092-003434-00000
ON PS F06 1D01	Pivot support for a wire feeder	092-003330-00000
ON PS F06 1D02	Pivot support for an IC wire feeder	092-003332-00000
ON PS EXT D01	Retrofit set: Extension turning mandrel, for holding a wire feeder with wheel kit ON WAK D01	092-002871-00000

9.6 Computer communication

Type	Designation	Item no.
PC300 XQ Set	PC300.Net welding parameter software kit incl. cable and SECINT X10 USB interface	090-008777-00000
ON WLG-EX	Wi-Fi gateway in external casing	090-008790-00502
ON LG-EX	LAN gateway in external casing	090-008789-00502

9.7 Component identification

Type	Designation	Item no.
SCAN BC 8Pol	Barcode scanner	090-008823-00000

10 Replaceable parts

Performance specifications and guarantee only in connection with original spare and replacement parts!

10.1 Wire feed rollers

10.1.1 Wire feed rollers for steel wire

Type	Designation	Item no.
FE 4R 0.6 MM/0.023 INCH LIGHT PINK	Drive roll set, 37 mm, 4 rolls, V-groove for steel, stainless steel and brazing	092-002770-00006
FE 4R 0.8-1.0MM / 0.03-0.04 INCH BLUE/WHITE	Drive roll set, 37 mm, 4 rolls, V-groove for steel, stainless steel and brazing	092-002770-00009
FE 4R 1.0-1.2MM / 0.04-0.045 INCH BLUE/RED	Drive roll set, 37 mm, 4 rolls, V-groove for steel, stainless steel and brazing	092-002770-00011
FE 4R 1.4 MM/0.052 INCH GREEN	Drive roll set, 37 mm, 4 rolls, V-groove for steel, stainless steel and brazing	092-002770-00014
FE 4R 1.6 MM/0.06 INCH BLACK	Drive roll set, 37 mm, 4 rolls, V-groove for steel, stainless steel and brazing	092-002770-00016
FE 4R 2.0 MM/0.08 INCH GREY	Drive roll set, 37 mm, 4 rolls, V-groove for steel, stainless steel and brazing	092-002770-00020
FE 4R 2.4 MM/0.095 INCH BROWN	Drive roll set, 37 mm, 4 rolls, V-groove for steel, stainless steel and brazing	092-002770-00024
FE 4R 2.8 MM/0.11 INCH LIGHT GREEN	Drive roll set, 37 mm, 4 rolls, V-groove for steel, stainless steel and brazing	092-002770-00028
FE 4R 3.2 MM/0.12 INCH VIOLET	Drive roll set, 37 mm, 4 rolls, V-groove for steel, stainless steel and brazing	092-002770-00032

10.1.2 Wire feed rollers for aluminium wire

Type	Designation	Item no.
AL 4R 0.8 MM/0.03 INCH WHITE/YELLOW	Drive roll set, 37 mm, for aluminium	092-002771-00008
AL 4R 1.0 MM/0.04 INCH BLUE/YELLOW	Drive roll set, 37 mm, for aluminium	092-002771-00010
AL 4R 1.2 MM/0.045 INCH RED/YELLOW	Drive roll set, 37 mm, for aluminium	092-002771-00012
AL 4R 1.6 MM/0.06 INCH BLACK/YELLOW	Drive roll set, 37 mm, for aluminium	092-002771-00016
AL 4R 2.0 MM/0.08 INCH GREY/YELLOW	Drive roll set, 37 mm, for aluminium	092-002771-00020
AL 4R 2.4 MM/0.095 INCH BROWN/YELLOW	Drive roll set, 37 mm, for aluminium	092-002771-00024
AL 4R 2.8 MM/0.110 INCH LIGHT GREEN/YELLOW	Drive roll set, 37 mm, for aluminium	092-002771-00028
AL 4R 3.2 MM/0.125 INCH VIOLET/YELLOW	Drive roll set, 37 mm, for aluminium	092-002771-00032

10.1.3 Wire feed rollers for cored wire

Type	Designation	Item no.
FUEL 4R 0.8 MM/0.03 INCH WHITE/ORANGE	Drive roll set, 37 mm, 4 rolls, V-groove/knurled for flux cored wire	092-002848-00008
FUEL 4R 1.0 MM/0.04 INCH BLUE/ORANGE	Drive roll set, 37 mm, 4 rolls, V-groove/knurled for flux cored wire	092-002848-00010
FUEL 4R 1.2 MM/0.045 INCH RED/ORANGE	Drive roll set, 37 mm, 4 rolls, V-groove/knurled for flux cored wire	092-002848-00012
FUEL 4R 1.4 MM/0.052 INCH GREEN/ORANGE	Drive roll set, 37 mm, 4 rolls, V-groove/knurled for flux cored wire	092-002848-00014
FUEL 4R 1.6 MM/0.06 INCH BLACK/ORANGE	Drive roll set, 37 mm, 4 rolls, V-groove/knurled for flux cored wire	092-002848-00016
FUEL 4R 2.0 MM/0.08 INCH GREY/ORANGE	Drive roll set, 37 mm, 4 rolls, V-groove/knurled for flux cored wire	092-002848-00020
FUEL 4R 2.4 MM/0.095 INCH BROWN/ORANGE	Drive roll set, 37 mm, 4 rolls, V-groove/knurled for flux cored wire	092-002848-00024

10.1.4 Wire guide

Type	Designation	Item no.
DV X	Wire feed roll mount set	092-002960-E0000
SET DRAHTFUERUNG	Wire guide set	092-002774-00000
ON WF 2,0-3,2mm eFeed	Retrofitting option, wire guide for 2.0–3.2 mm wires, eFeed drive	092-019404-00000
SET IG 4x4 1.6mm BL	Inlet guide set	092-002780-00000
GUIDE TUBE L105	Guide tube	094-006051-00000
CAPTUB L=107 mm; Ø ≤ 1,6 mm	Capillary tube	094-006634-00000
CAPTUB L=105 mm; Ø ≤ 2,4 mm	Capillary tube	094-021470-00000

11 Appendix

11.1 Searching for a dealer

Sales & service partners
www.ewm-group.com/en/specialist-dealers



"More than 400 EWM sales partners worldwide"