



**EN**

**welding torch**

**UM 15 G EZA  
UM 24 G EZA  
UM 25 G EZA  
UM 36 G EZA  
UM 240 W EZA  
UM 401 W EZA  
UM 501 W EZA**

# General instructions

## WARNING



### **Read the operating instructions!**

#### **The operating instructions provide an introduction to the safe use of the products.**

- Read and observe the operating instructions for all system components, especially the safety instructions and warning notices!
- Observe the accident prevention regulations and any regional regulations!
- The operating instructions must be kept at the location where the machine is operated.
- Safety and warning labels on the machine indicate any possible risks. Keep these labels clean and legible at all times.
- The machine has been constructed to state-of-the-art standards in line with any applicable regulations and industrial standards. Only trained personnel may operate, service and repair the machine.
- Technical changes due to further development in machine technology may lead to a differing welding behaviour.

**In the event of queries on installation, commissioning, operation or special conditions at the installation site, or on usage, please contact your sales partner or our customer service department on +49 2680 181-0.**

**A list of authorised sales partners can be found at [www.ewm-group.com/en/specialist-dealers](http://www.ewm-group.com/en/specialist-dealers).**

Liability relating to the operation of this equipment is restricted solely to the function of the equipment. No other form of liability, regardless of type, shall be accepted. This exclusion of liability shall be deemed accepted by the user on commissioning the equipment.

The manufacturer is unable to monitor whether or not these instructions or the conditions and methods are observed during installation, operation, usage and maintenance of the equipment.

An incorrectly performed installation can result in material damage and injure persons as a result. For this reason, we do not accept any responsibility or liability for losses, damages or costs arising from incorrect installation, improper operation or incorrect usage and maintenance or any actions connected to this in any way.

© **EWM AG**

Dr. Günter-Henle-Strasse 8

56271 Mündersbach Germany

Tel.: +49 2680 181-0, Fax: -244

Email: [info@ewm-group.com](mailto:info@ewm-group.com)

**[www.ewm-group.com](http://www.ewm-group.com)**

The copyright to this document remains the property of the manufacturer.

Copying, including extracts, only permitted with written approval.

The content of this document has been prepared and reviewed with all reasonable care. The information provided is subject to change; errors excepted.

### **Data security**

The user is responsible for backing up data of all changes from the factory setting. The user is liable for erased personal settings. The manufacturer does not assume any liability for this.

<b>1</b>	<b>Contents</b>	
<b>1</b>	<b>Contents</b> .....	<b>3</b>
<b>2</b>	<b>For your safety</b> .....	<b>5</b>
2.1	Notes on using these operating instructions .....	5
2.2	Explanation of icons .....	6
2.3	Safety instructions.....	7
2.4	Transport and installation .....	10
<b>3</b>	<b>Intended use</b> .....	<b>12</b>
3.1	Applications.....	12
3.2	Documents which also apply .....	12
3.2.1	Warranty .....	12
3.2.2	Declaration of Conformity.....	12
3.2.3	Service documents (spare parts) .....	12
3.2.4	Part of the complete documentation.....	13
<b>4</b>	<b>Product description – quick reference</b> .....	<b>14</b>
4.1	Machine variants.....	14
4.2	Welding torch .....	14
4.2.1	UM 15 G, -24 G, -25 G, -36 G .....	14
4.2.1.1	Euro central connection .....	14
4.2.2	UM 240 W, -401 W, -501 W .....	15
4.2.2.1	Euro central connection .....	15
<b>5</b>	<b>Design and function</b> .....	<b>16</b>
5.1	General .....	16
5.2	Scope of delivery .....	16
5.3	Transport and installation .....	17
5.3.1	Ambient conditions .....	17
5.3.2	Welding torch cooling system.....	17
5.3.2.1	Permitted torch coolant .....	17
5.3.2.2	Maximal hose package length .....	18
5.4	Adapting the Euro torch connection on the device .....	18
5.4.1	Liner.....	18
5.4.2	Replace steel liner .....	18
5.4.3	Assemble the wire guide .....	19
5.4.3.1	Guide spiral .....	19
5.4.3.2	Combined liner.....	23
<b>6</b>	<b>Maintenance, care and disposal</b> .....	<b>26</b>
6.1	General .....	26
6.1.1	Identifying damage or worn components .....	26
6.1.2	Maintenance and care before each use .....	28
6.1.3	Regular maintenance .....	29
6.2	Disposing of equipment .....	30
<b>7</b>	<b>Rectifying faults</b> .....	<b>31</b>
7.1	Checklist for rectifying faults .....	31
7.2	Vent coolant circuit.....	33
<b>8</b>	<b>Technical data</b> .....	<b>34</b>
8.1	UM 15 G, -24 G, -25 G, -36 G .....	34
8.2	UM 240 W, -401 W, -501 W.....	35
<b>9</b>	<b>Accessories</b> .....	<b>36</b>
9.1	List of tools .....	36
9.2	General accessories .....	36
9.3	Welding torch cooling system .....	36
9.3.1	Coolant - type blueCool.....	36
9.3.2	Coolant - type KF.....	36
<b>10</b>	<b>Replaceable parts</b> .....	<b>37</b>
10.1	UM 15 G.....	37
10.2	UM 24 G.....	38
10.3	UM 25 G.....	39

---

10.4	UM 36 G .....	40
10.5	UM 240 W .....	41
10.6	UM 401 W / UM 501 W .....	42
<b>11</b>	<b>Appendix .....</b>	<b>43</b>
11.1	Searching for a dealer .....	43

## 2 For your safety

### 2.1 Notes on using these operating instructions

#### **DANGER**

**Working or operating procedures which must be closely observed to prevent imminent serious and even fatal injuries.**

- Safety notes include the "DANGER" keyword in the heading with a general warning symbol.
- The hazard is also highlighted using a symbol on the edge of the page.

#### **WARNING**

**Working or operating procedures which must be closely observed to prevent serious and even fatal injuries.**

- Safety notes include the "WARNING" keyword in the heading with a general warning symbol.
- The hazard is also highlighted using a symbol in the page margin.

#### **CAUTION**

**Working or operating procedures which must be closely observed to prevent possible minor personal injury.**

- The safety information includes the "CAUTION" keyword in its heading with a general warning symbol.
- The risk is explained using a symbol on the edge of the page.



***Technical aspects which the user must observe to avoid material or equipment damage.***

Instructions and lists detailing step-by-step actions for given situations can be recognised via bullet points, e.g.:

- Insert the welding current lead socket into the relevant socket and lock.

## 2.2 Explanation of icons

Symbol	Description	Symbol	Description
	Indicates technical aspects which the user must observe.		Activate and release / Tap / Tip
	Switch off machine		Release
	Switch on machine		Press and hold
	Incorrect / Invalid		Switch
	Correct / Valid		Turn
	Input		Numerical value – adjustable
	Navigation		Signal light lights up in green
	Output		Signal light flashes green
	Time representation (e.g.: wait 4 s / actuate)		Signal light lights up in red
	Interruption in the menu display (other setting options possible)		Signal light flashes red
	Tool not required/do not use		Signal light lights up in blue
	Tool required/use		Signal light flashes blue

## 2.3 Safety instructions

### **WARNING**



**Risk of accidents due to non-compliance with the safety instructions!**  
**Non-compliance with the safety instructions can be fatal!**

- Carefully read the safety instructions in this manual!
- Observe the accident prevention regulations and any regional regulations!
- Inform persons in the working area that they must comply with the regulations!



**Risk of injury from electrical voltage!**

**Voltages can cause potentially fatal electric shocks and burns on contact. Even low voltages can cause a shock and lead to accidents.**

- Never touch live components such as welding current sockets or stick, tungsten or wire electrodes!
- Always place torches and electrode holders on an insulated surface!
- Wear the full personal protective equipment (depending on the application)!
- The machine may only be opened by qualified personnel!
- The device must not be used to defrost pipes!



**Hazard when interconnecting multiple power sources!**

**If a number of power sources are to be connected in parallel or in series, only a technical specialist may interconnect the sources as per standard IEC 60974-9:2010: Installation and use and German Accident Prevention Regulation BVG D1 (formerly VBG 15) or country-specific regulations.**

**Before commencing arc welding, a test must verify that the equipment cannot exceed the maximum permitted open circuit voltage.**

- Only qualified personnel may connect the machine.
- When taking individual power sources out of operation, all mains and welding current leads must be safely disconnected from the welding system as a whole. (Hazard due to reverse polarity voltage!)
- Do not interconnect welding machines with pole reversing switch (PWS series) or machines for AC welding since a minor error in operation can cause the welding voltages to be combined, which is not permitted.



**Risk of injury due to radiation or heat!**

**Arc radiation can lead to skin and eye injuries.**

**Contact with hot workpieces and sparks can lead to burns.**

- Use hand shield or welding helmet with the appropriate safety level (depends on the application).
- Wear dry protective clothing (e.g. hand shield, gloves, etc.) in accordance with the applicable regulations of your country.
- Persons who are not directly involved should be protected with a welding curtain or suitable safety screen against radiation and the risk of blinding!

## **WARNING**



### **Risk of injury due to improper clothing!**

**During arc welding, radiation, heat and voltage are sources of risk that cannot be avoided. The user has to be equipped with the complete personal protective equipment at all times. The protective equipment has to include:**

- Respiratory protection against hazardous substances and mixtures (fumes and vapours); otherwise implement suitable measures such as extraction facilities.
- Welding helmet with proper protection against ionizing radiation (IR and UV radiation) and heat.
- Dry welding clothing (shoes, gloves and body protection) to protect against warm environments with conditions comparable to ambient temperatures of 100 °C or higher and arcing and work on live components.
- Hearing protection against harming noise.



### **Explosion risk!**

**Apparently harmless substances in closed containers may generate excessive pressure when heated.**

- Move containers with inflammable or explosive liquids away from the working area!
- Never heat explosive liquids, dusts or gases by welding or cutting!



### **Fire hazard!**

**Due to the high temperatures, sparks, glowing parts and hot slag that occur during welding, there is a risk of flames.**

- Be watchful of potential sources of fire in the working area!
- Do not carry any easily inflammable objects, e.g. matches or lighters.
- Ensure suitable fire extinguishers are available in the working area!
- Thoroughly remove any residue of flammable materials from the workpiece prior to starting to weld.
- Only further process workpieces after they have cooled down. Do not allow them to contact any flammable materials!



## ⚠ CAUTION



### Smoke and gases!

**Smoke and gases may lead to shortness of breath and poisoning! The ultraviolet radiation of the arc may also convert solvent vapours (chlorinated hydrocarbon) into poisonous phosgene.**

- Ensure sufficient fresh air!
- Keep solvent vapours away from the arc beam field!
- Wear suitable respiratory protection if necessary!
- To prevent the formation of phosgene, residues of chlorinated solvents on workpieces must first be neutralised using appropriate measures.



### Noise exposure!

**Noise exceeding 70 dBA can cause permanent hearing damage!**

- Wear suitable ear protection!
- Persons located within the working area must wear suitable ear protection!



**According to IEC 60974-10, welding machines are divided into two classes of electromagnetic compatibility (the EMC class can be found in the Technical data) > see 8 chapter:**



**Class A** machines are not intended for use in residential areas where the power supply comes from the low-voltage public mains network. When ensuring the electromagnetic compatibility of class A machines, difficulties can arise in these areas due to interference not only in the supply lines but also in the form of radiated interference.



**Class B** machines fulfil the EMC requirements in industrial as well as residential areas, including residential areas connected to the low-voltage public mains network.

### Setting up and operating

When operating arc welding systems, in some cases, electro-magnetic interference can occur although all of the welding machines comply with the emission limits specified in the standard. The user is responsible for any interference caused by welding.

In order to **evaluate** any possible problems with electromagnetic compatibility in the surrounding area, the user must consider the following: (see also EN 60974-10 Appendix A)

- Mains, control, signal and telecommunication lines
- Radios and televisions
- Computers and other control systems
- Safety equipment
- The health of neighbouring persons, especially if they have a pacemaker or wear a hearing aid
- Calibration and measuring equipment
- The immunity to interference of other equipment in the surrounding area
- The time of day at which the welding work must be carried out

### Recommendations for **reducing interference emission**

- Mains connection, e.g. additional mains filter or shielding with a metal tube
- Maintenance of the arc welding system
- Welding leads should be as short as possible and run closely together along the ground
- Potential equalization
- Earthing of the workpiece. In cases where it is not possible to earth the workpiece directly, it should be connected by means of suitable capacitors.
- Shielding from other equipment in the surrounding area or the entire welding system



### Electromagnetic fields!

**The power source can create electrical or electromagnetic fields that may impair the function of electronic systems such as EDP and CNC devices, telecommunication, power and signal lines as well as pacemakers and defibrillators.**



- Follow the maintenance instructions > see 6 chapter!
- Unwind the welding leads completely!
- Shield radiation-sensitive equipment or facilities appropriately!
- The function of pacemakers may be impaired (seek medical advice if necessary).

## CAUTION



### Obligations of the operator!

**The respective national directives and laws must be complied with when operating the machine!**

- Implementation of national legislation relating to framework directive 89/391/EEC on the introduction of measures to encourage improvements in the safety and health of workers at work and associated individual guidelines.
- In particular, directive 89/655/EEC concerning the minimum safety and health requirements for the use of work equipment by workers at work.
- The regulations applicable to occupational safety and accident prevention in the country concerned.
- Setting up and operating the machine as per IEC 60974.-9.
- Brief the user on safety-conscious work practices on a regular basis.
- Regularly inspect the machine as per IEC 60974.-4.



***The manufacturer's warranty becomes void if non-genuine parts are used!***

- ***Only use system components and options (power sources, welding torches, electrode holders, remote controls, spare parts and replacement parts, etc.) from our range of products!***
- ***Only insert and lock accessory components into the relevant connection socket when the machine is switched off.***

### Requirements for connection to the public mains network

High-performance machines can influence the mains quality by taking current from the mains network. For some types of machines, connection restrictions or requirements relating to the maximum possible line impedance or the necessary minimum supply capacity at the interface with the public network (Point of Common Coupling, PCC) can therefore apply. In this respect, attention is also drawn to the machines' technical data. In this case, it is the responsibility of the operator, where necessary in consultation with the mains network operator, to ensure that the machine can be connected.

## 2.4 Transport and installation

## WARNING



### Risk of injury due to improper handling of shielding gas cylinders!

**Improper handling and insufficient securing of shielding gas cylinders can cause serious injuries!**

- Observe the instructions from the gas manufacturer and any relevant regulations concerning the use of compressed air!
- Do not attach any element to the shielding gas cylinder valve!
- Prevent the shielding gas cylinder from heating up.

**⚠ CAUTION****Risk of accidents due to supply lines!**

During transport, attached supply lines (mains leads, control cables, etc.) can cause risks, e.g. by causing connected machines to tip over and injure persons!

- Disconnect all supply lines before transport!

**Risk of tipping!**

There is a risk of the machine tipping over and injuring persons or being damaged itself during movement and set up. Tilt resistance is guaranteed up to an angle of 10° (according to IEC 60974-1).

- Set up and transport the machine on level, solid ground.
- Secure add-on parts using suitable equipment.

**Risk of accidents due to incorrectly installed leads!**

Incorrectly installed leads (mains, control and welding leads or intermediate hose packages) can present a tripping hazard.

- Lay the supply lines flat on the floor (avoid loops).
- Avoid laying the leads on passage ways.

**Risk of injury from heated coolant and its connections!**

The coolant used and its connection or connection points can heat up significantly during operation (water-cooled version). When opening the coolant circuit, escaping coolant may cause scalding.

- Open the coolant circuit only when the power source or cooling unit is switched off!
- Wear proper protective equipment (protective gloves)!
- Seal open connections of the hose leads with suitable plugs.



***The units are designed for operation in an upright position!***

***Operation in non-permissible positions can cause equipment damage.***

- ***Only transport and operate in an upright position!***



***Accessory components and the power source itself can be damaged by incorrect connection!***

- ***Only insert and lock accessory components into the relevant connection socket when the machine is switched off.***
- ***Comprehensive descriptions can be found in the operating instructions for the relevant accessory components.***
- ***Accessory components are detected automatically after the power source is switched on.***



***Protective dust caps protect the connection sockets and therefore the machine against dirt and damage.***

- ***The protective dust cap must be fitted if there is no accessory component being operated on that connection.***
- ***The cap must be replaced if faulty or if lost!***

## 3 Intended use

### **WARNING**



#### **Hazards due to improper usage!**

The machine has been constructed to the state of the art and any regulations and standards applicable for use in industry and trade. It may only be used for the welding procedures indicated at the rating plate. Hazards may arise for persons, animals and material objects if the equipment is not used correctly. No liability is accepted for any damages arising from improper usage!

- The equipment must only be used in line with its designated purpose and by trained or expert personnel!
- Do not improperly modify or convert the equipment!

### 3.1 Applications

Welding torch for arc welding machines for GMAW.

### 3.2 Documents which also apply

#### 3.2.1 Warranty

For more information refer to the "Warranty registration" brochure supplied and our information regarding warranty, maintenance and testing at [www.ewm-group.com](http://www.ewm-group.com)!

#### 3.2.2 Declaration of Conformity



This product corresponds in its design and construction to the EU directives listed in the declaration. The product comes with a relevant declaration of conformity in the original.

The manufacturer recommends carrying out the safety inspection according to national and international standards and guidelines every 12 months (from commissioning).

#### 3.2.3 Service documents (spare parts)

### **WARNING**



#### **No improper repairs and modifications!**

To prevent injuries and damage to the machine, only competent personnel (authorised service personnel) are allowed to repair or modify the machine.

**Unauthorised manipulations will invalidate the warranty!**

- Instruct competent personnel (authorised service personnel) to repair the machine.

Spare parts can be obtained from the relevant authorised dealer.

### 3.2.4 Part of the complete documentation

This document is part of the complete documentation and valid only in combination with all other parts of these instructions! Read and observe the operating instructions for all system components, especially the safety instructions!

The illustration shows a general example of a welding system.

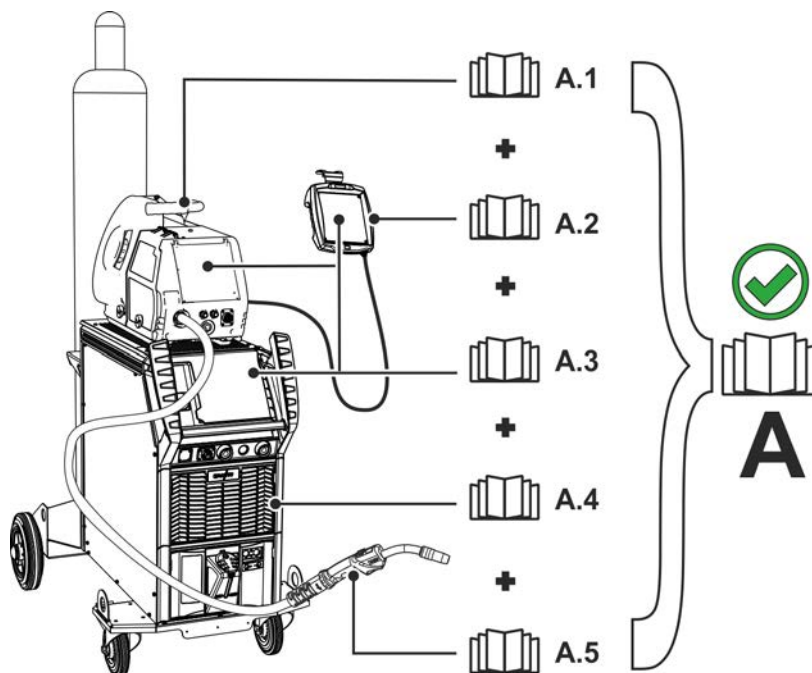

Figure 3-1

The illustration shows a general example of a welding system.

Item	Documentation
A.1	Wire feeder
A.2	Remote adjuster
A.3	Controller
A.4	Power source
A.5	Welding torch
A	Complete documentation

## 4 Product description – quick reference

### 4.1 Machine variants

Version	Functions	Rated output
G	Gas-cooled with Euro torch connector	UM 15 G, -24 G, -25 G, -36 G
W	Water-cooled with Euro torch connector	UM 240 W, -401 W, -501 W

### 4.2 Welding torch

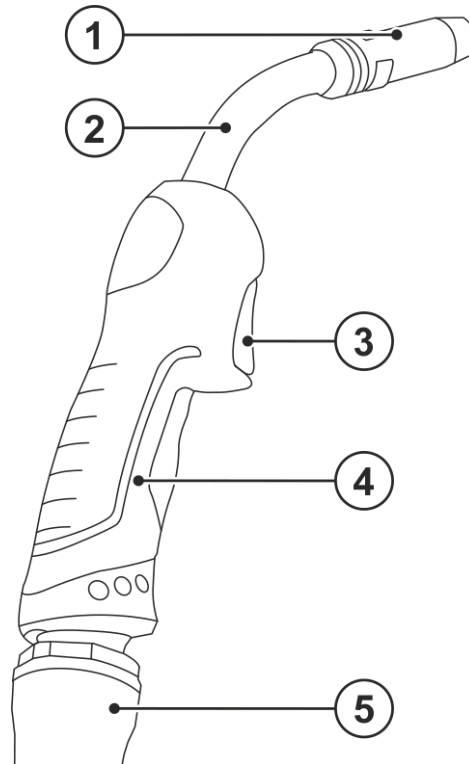

Figure 4-1

Item	Symbol	Description
1		Gas nozzle
2		Torch neck 45°
3		Torch trigger
4		Grip plate
5		Hose package

#### 4.2.1 UM 15 G, -24 G, -25 G, -36 G

##### 4.2.1.1 Euro central connection

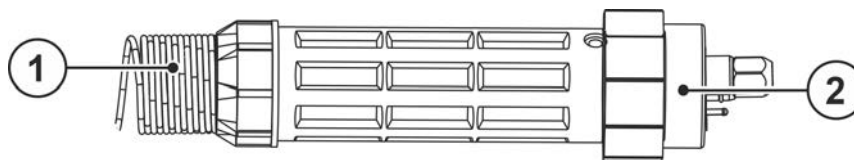

Figure 4-2

Item	Symbol	Description
1		Anti-kink spring
2		Euro central connection Welding current, shielding gas and torch trigger included

## 4.2.2 UM 240 W, -401 W, -501 W

### 4.2.2.1 Euro central connection

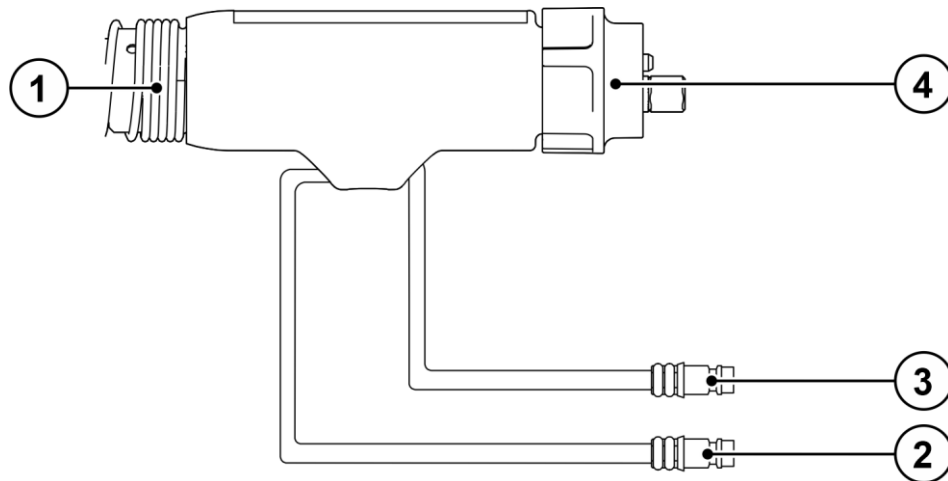



Figure 4-3

Item	Symbol	Description
1		Anti-kink spring
2		Quick connect coupling, red (coolant return)
3		Quick connect coupling, blue (coolant supply)
4		<b>Euro central connection</b> Welding current, shielding gas and torch trigger included

## 5 Design and function

### 5.1 General

#### **WARNING**



**Risk of injury from electrical voltage!**

**Contact with live parts, e.g. power connections, can be fatal!**

- Observe the safety information on the first pages of the operating instructions!
- Commissioning must be carried out by persons who are specifically trained in handling power sources!
- Connect connection or power cables while the machine is switched off!



**Risk of burns and electric shock on the welding torch!**

**Welding torch (torch neck or torch head) and coolant (water-cooled version) heat up strongly during the welding process. During assembly work, you may come into touch with electrical voltage or hot components.**

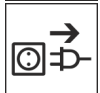

- Wear proper protective equipment!
- Switch off the power source or torch cooling and allow the welding torch to cool!

#### **CAUTION**



**Risk of injury from heated coolant and its connections!**

**The coolant used and its connection or connection points can heat up significantly during operation (water-cooled version). When opening the coolant circuit, escaping coolant may cause scalding.**

- Open the coolant circuit only when the power source or cooling unit is switched off!
- Wear proper protective equipment (protective gloves)!
- Seal open connections of the hose leads with suitable plugs.



**Risk from electrical current!**

**If welding is carried out alternately using different methods and if a welding torch and an electrode holder remain connected to the machine, the open-circuit/welding voltage is applied simultaneously on all cables.**

- The torch and the electrode holder should therefore always be placed on an insulated surface before starting work and during breaks.



**After each opening of the welding torch, using the "gas test" "gas flush" function and increased flow rates, remove moisture, atmospheric oxygen and any impurities from the welding torch.**



**Machine damage due to incompletely assembled welding torch!**

**Incomplete assembly may destroy the welding torch.**

- **Always assemble the welding torch completely.**

**Read and observe the documentation to all system and accessory components!**

### 5.2 Scope of delivery

The delivery is checked and packaged carefully before dispatch, however it is not possible to exclude the possibility of damage during transit.

#### **Receiving inspection**

- Check that the delivery is complete using the delivery note!

#### **In the event of damage to the packaging**

- Check the delivery for damage (visual inspection)!

#### **In the event of complaints**

If the delivery has been damaged during transport:

- Please contact the last haulier immediately!
- Keep the packaging (for possible checking by the haulier or for the return shipment).

#### **Packaging for returns**

If possible, please use the original packaging and the original packaging material. If you have any queries on packaging and protection during transport, please contact your supplier.



## 5.3 Transport and installation

### ⚠ CAUTION



**Risk of accidents due to supply lines!**

**During transport, attached supply lines (mains leads, control cables, etc.) can cause risks, e.g. by causing connected machines to tip over and injure persons!**

- Disconnect all supply lines before transport!

### 5.3.1 Ambient conditions



**Equipment damage due to contamination!**

**Unusually high amounts of dust, acids, corrosive gases or substances can damage the machine (observe maintenance intervals > see 6.1.2 chapter).**

- **Avoid large amounts of smoke, steam, oily fumes, grinding dust and corrosive ambient air!**

#### In operation

Temperature range of the ambient air:

- -10 °C to +40 °C (-13 F to 104 F) <sup>[1]</sup>

Relative humidity:

- up to 50 % at 40 °C (104 F)
- up to 90 % at 20 °C (68 F)

#### Transport and storage

Storage in a closed area, temperature range of the ambient air:

- -25 °C to +55 °C (-13 F to 131 F) <sup>[1]</sup>

Relative humidity

- up to 90 % at 20 °C (68 F)

<sup>[1]</sup> Ambient temperature dependent on coolant! Observe the coolant temperature range of the torch cooling

### 5.3.2 Welding torch cooling system



**Material damage due to unsuitable coolants!**

**Unsuitable coolant, coolants mixed with other types / liquids or use in an unsuitable temperature range will result in material damage and loss of the manufacturer's warranty!**

- **Operation without coolant is not permitted! Dry running will destroy the cooling components such as the coolant pump, welding torch and hose packages.**
- **Only use the coolants described in these instructions for the specified ambient conditions (temperature range) > see 5.3.2.1 chapter.**
- **Do not mix coolants of different types (including those described in these instructions).**
- **When changing the coolant, all liquid must be replaced and the cooling system flushed.**

Dispose of the coolant in accordance with local regulations and the material safety data sheets.

#### 5.3.2.1 Permitted torch coolant

Coolant	Temperature range
blueCool -10	-10 °C to +40 °C (14 °F to +104 °F)
KF 23E (Standard)	-10 °C to +40 °C (14 °F to +104 °F)
KF 37E	-20 °C to +30 °C (-4 °F to +86 °F)
blueCool -30	-30 °C to +40 °C (-22 °F to +104 °F)

## 5.3.2.2 Maximal hose package length

All information relates to the total hose package length of the complete welding system and presents exemplary configurations (of components of the EWM product portfolio with standard lengths). A straight kink-free installation is to be ensured, taking into account the max. delivery height.

**Pump: Pmax = 3,5 bar (0.35 MPa)**

Power source	Hose package	Wire feeder	miniDrive	Welding torch	Max.
Compact	✗	✗	✓ (25 m / 82 ft.)	✓ (5 m / 16 ft.)	30 m 98 ft.
	✓ (20 m / 65 ft.)	✓	✗	✓ ✓ (5 m / 16 ft.)	
Decompact	✓ (25 m / 82 ft.)	✓	✗	✓ (5 m / 16 ft.)	
	✓ (15 m / 49 ft.)	✓	✓ (10 m / 32 ft.)	✓ (5 m / 16 ft.)	

**Pump: Pmax = 4.5 bar (0.45 MPa)**

Power source	Hose package	Wire feeder	miniDrive	Welding torch	Max.
Compact	✗	✗	✓ (25 m / 82 ft.)	✓ (5 m / 16 ft.)	30 m 98 ft.
	✓ (30 m / 98 ft.)	✓	✗	✓ ✓ (5 m / 16 ft.)	40 m 131 ft.
Decompact	✓ (40 m / 131 ft.)	✓	✗	✓ (5 m / 16 ft.)	45 m 147 ft.
	✓ (40 m / 131 ft.)	✓	✓ (25 m / 82 ft.)	✓ (5 m / 16 ft.)	70 m 229 ft.

## 5.4 Adapting the Euro torch connection on the device

On delivery, the Euro torch connector on the wire feeder is fitted with a capillary tube for welding torches with a steel liner!

### 5.4.1 Liner

- Push forward the capillary tube on the wire feed side in the direction of the Euro torch connector and remove it there.
- Insert the guide tube from the Euro torch connection.
- Insert the welding torch connector with the excessively long liner carefully into the Euro torch connector and screw hand-tight using the crown nut.
- Cut off the liner using a special cutter or sharp knife just before the wire feed roller, making sure not to pinch it.
- Loosen the welding torch connector and remove.
- Cleanly trim the separated end of the liner!

### 5.4.2 Replace steel liner

- Check the Euro torch connector for correct seating of the capillary tube!

## 5.4.3 Assemble the wire guide

Use the correct wire guide from spool to molten pool!

The wire guide has to be adjusted to the wire electrode type and diameter in order to achieve good welding results!

- Equip the wire feeder according to wire electrode type and diameter!
- Refer to the manufacturer instructions for the right wire feed unit equipment. Refer to Annex 1 in these operating instructions for the right EWM machine equipment > see 10 chapter.
- Use a steel liner inside the torch hose package to guide hard, unalloyed wire electrodes (steel)!
- Use a plastic liner inside the torch hose package to guide soft or alloyed wire electrodes!

**Equipment side for steel liner or liner.**

### 5.4.3.1 Guide spiral

**Insert the grinded end towards the contact tip holder to ensure tight fit with the contact tip.**

**Always make sure the hose package is straight when replacing the wire guide.**

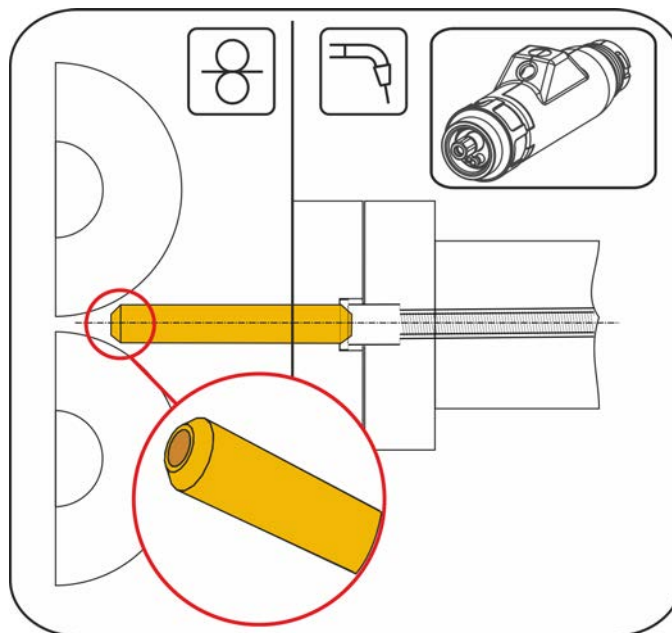

Figure 5-1

1.

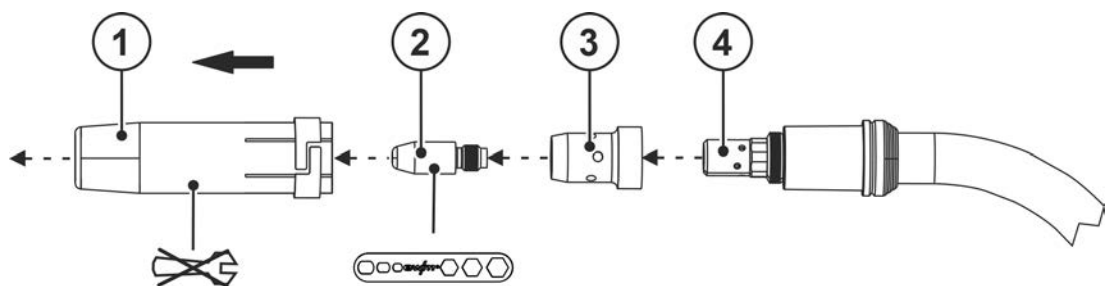

Figure 5-2

2.

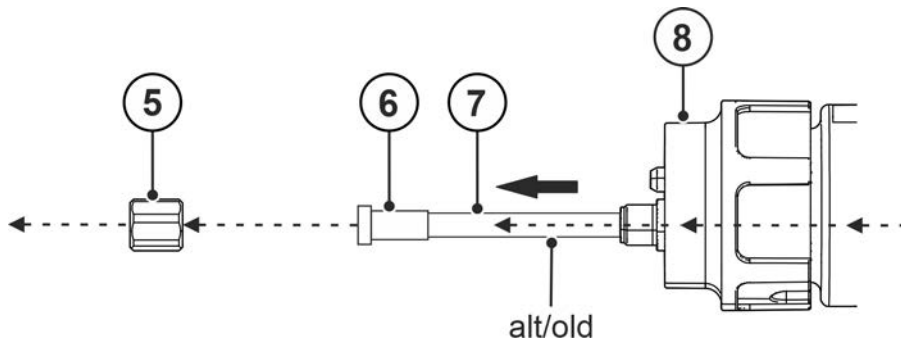

Figure 5-3

3.

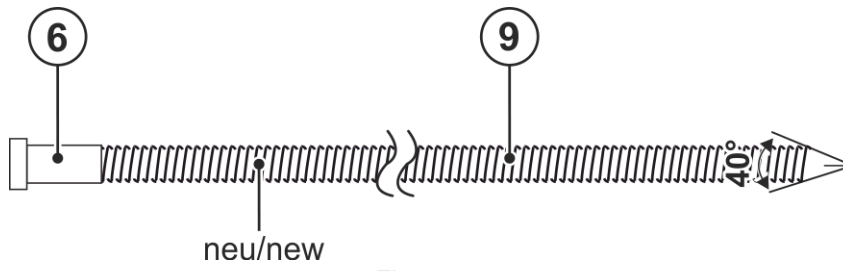

Figure 5-4

4.

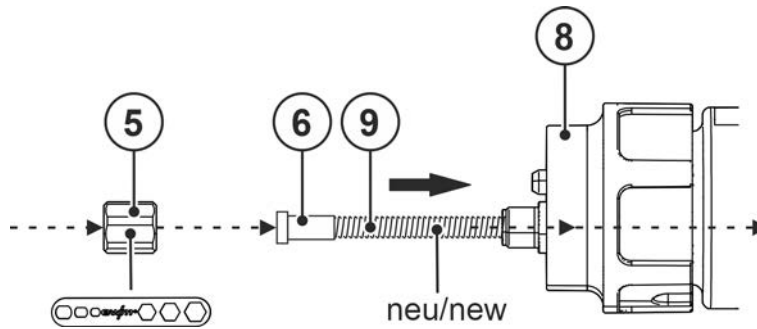

Figure 5-5

5.

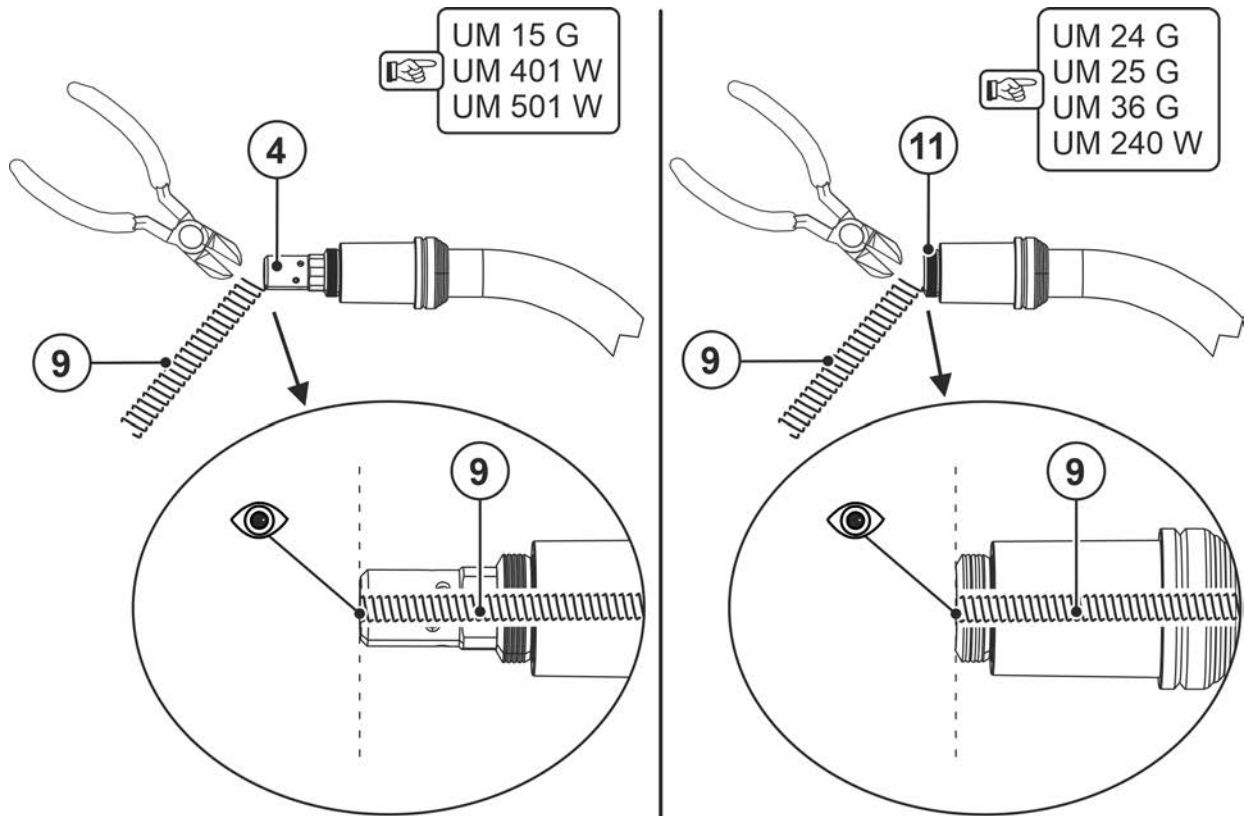

Figure 5-6

6.

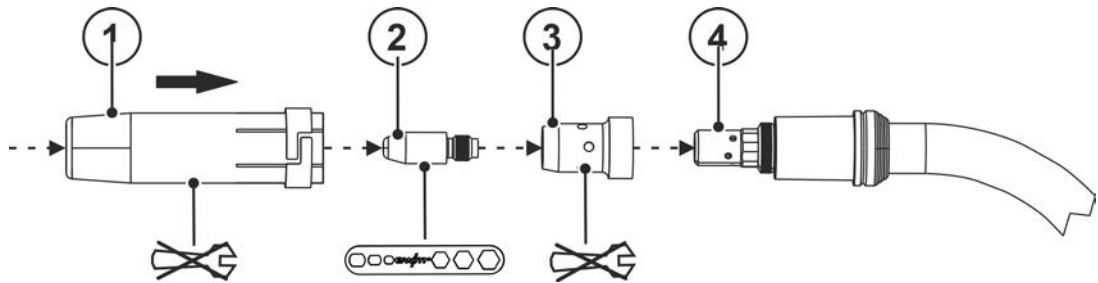

Figure 5-7

7.

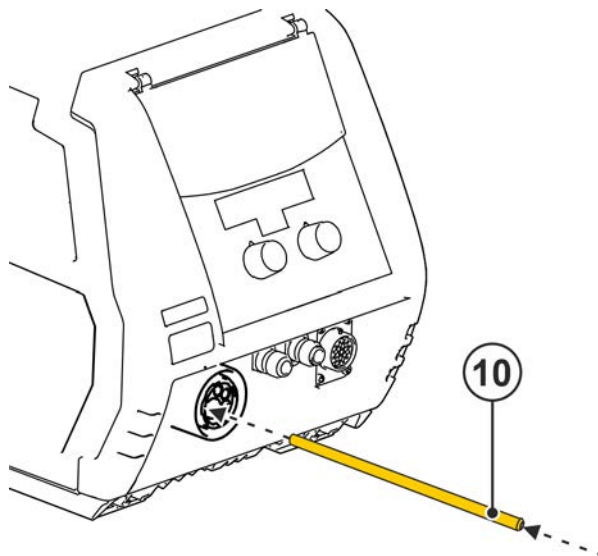

Figure 5-8

Item	Symbol	Description
1		Gas nozzle
2		Contact tip
3		Gas distributor
4		Contact tip holder
5		Crown nut, welding torch central connection (euro)
6		Centring sleeve
7		old spiral guide
8		Euro central connection
9		new spiral guide
10		Capillary tube
11		Welding torch head

### 5.4.3.2 Combined liner

The distance between the plastic liner and drive rollers should be as short as possible.

Use only sharp, stable knives or special tongs for cutting to ensure that the plastic liner does not become misshapen!

Always make sure the hose package is straight when replacing the wire guide.

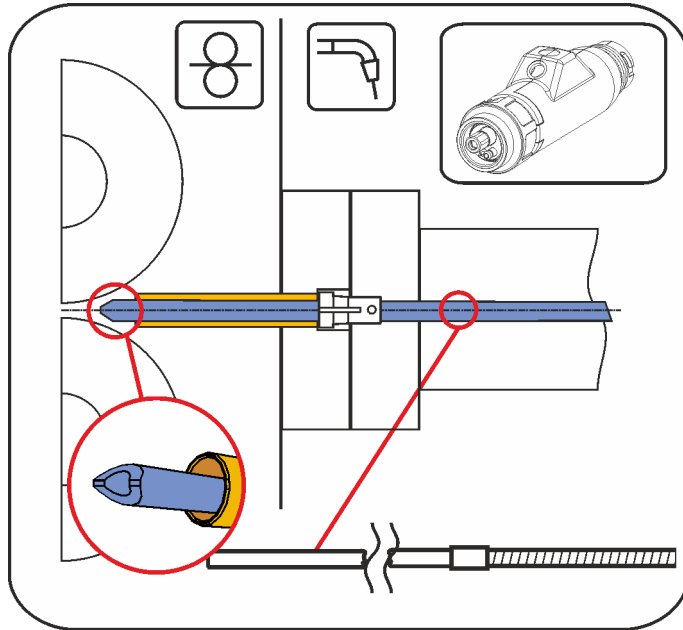

Figure 5-9

1.

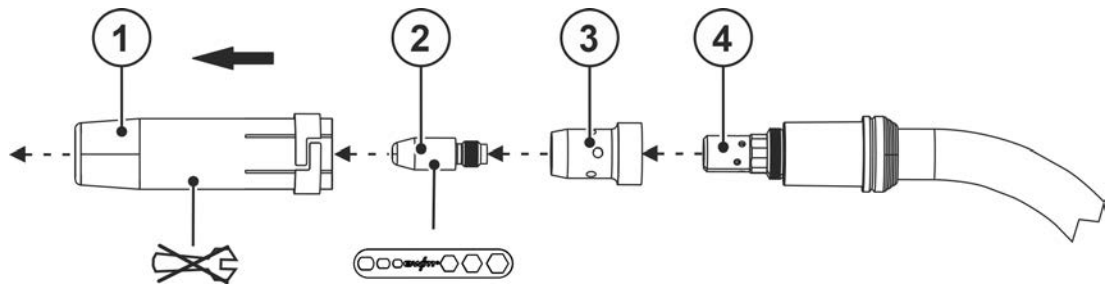

Figure 5-10

2.

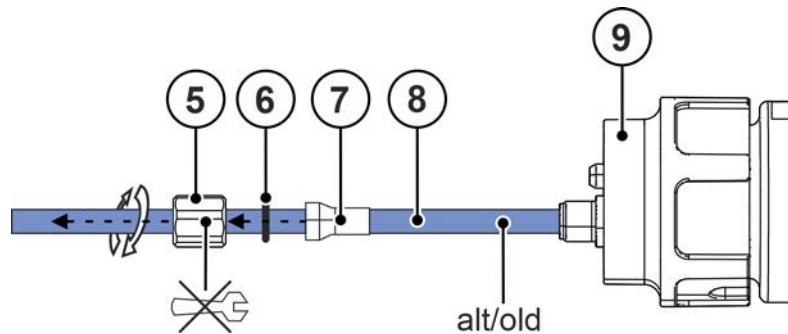

Figure 5-11

3.

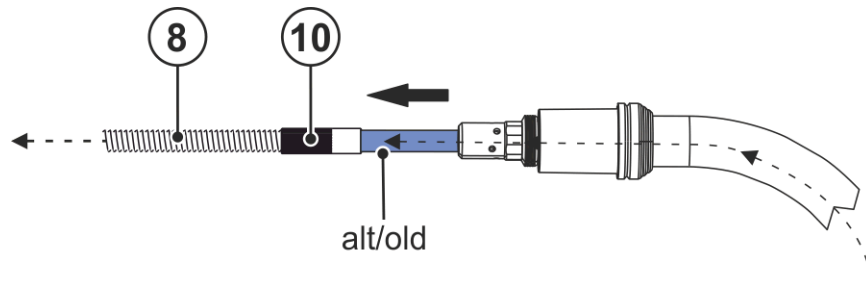

Figure 5-12

4.

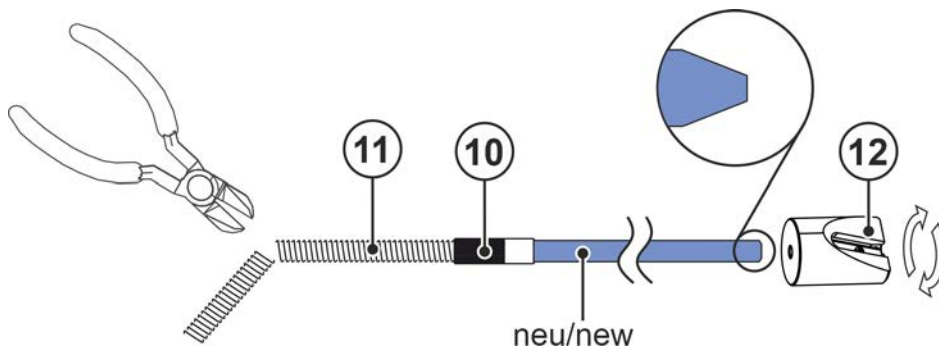

Figure 5-13

5.

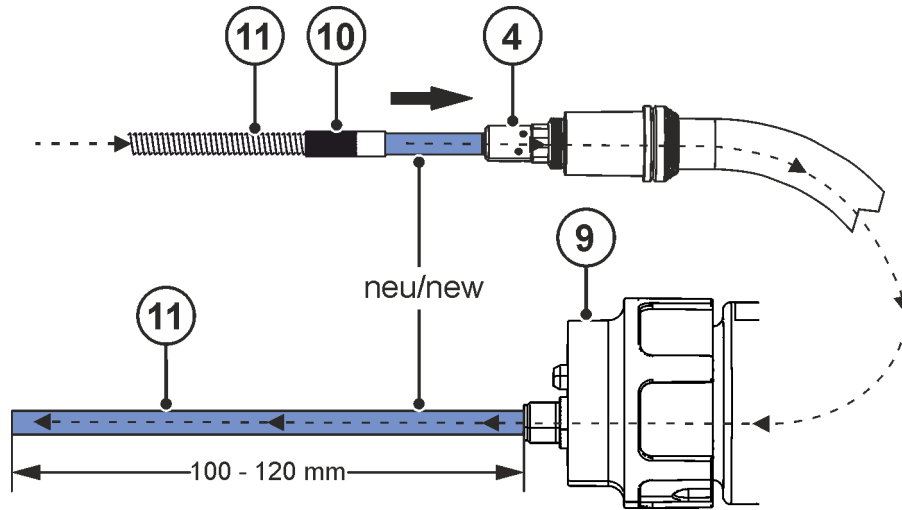

Figure 5-14

6.

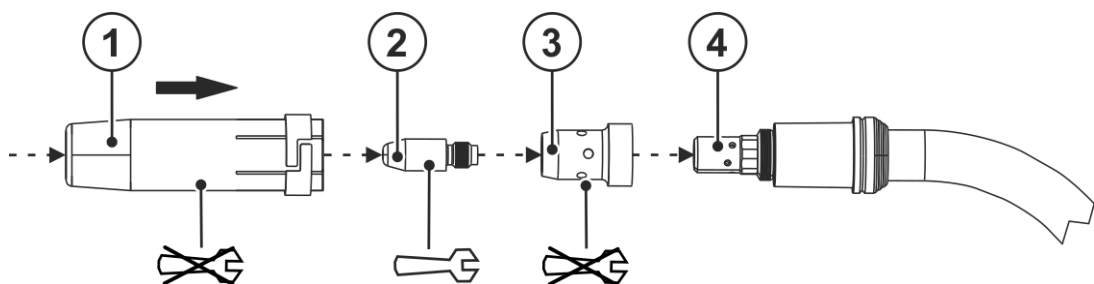

Figure 5-15



7.

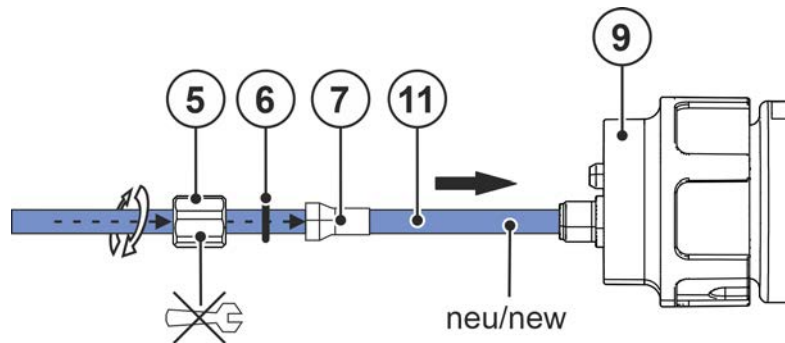

Figure 5-16

8.

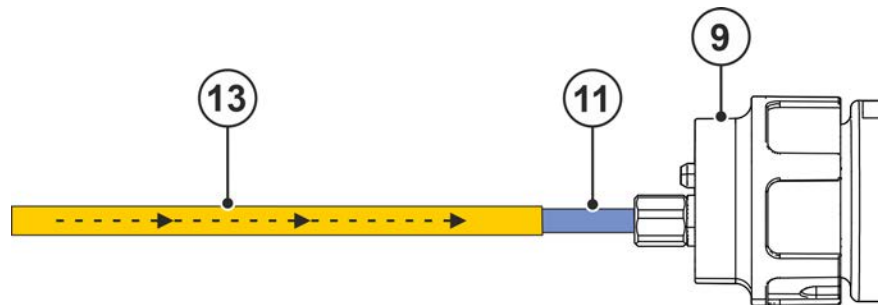

Figure 5-17

Item	Symbol	Description
1		Gas nozzle
2		Contact tip
3		Gas distributor
4		Contact tip holder
5		Crown nut
6		O-ring
7		Collet
8		Combined liner
9		Euro central connection
10		Connecting sleeve
11		New combined liner
12		Liner sharpener > see 9 chapter
13		Guiding tube for welding torch Euro torch connector

## 6 Maintenance, care and disposal

### 6.1 General

#### DANGER



**Risk of injury due to electrical voltage after switching off!**

**Working on an open machine can lead to fatal injuries!**

**Capacitors are loaded with electrical voltage during operation. Voltage remains present for up to four minutes after the mains plug is removed.**

1. Switch off machine.
2. Remove the mains plug.
3. Wait for at least 4 minutes until the capacitors have discharged!

#### WARNING



**Improper maintenance, testing and repairs!**

**Maintenance, testing and repair of the machine may only be carried out by skilled and qualified personnel (authorised service personnel). A competent person is someone who, based on training, knowledge and experience, can recognize the hazards and possible consequential damage that may occur when testing power sources and can take the necessary safety precautions.**

- Follow the maintenance instructions > see 6.1.3 chapter.
- If any of the test requirements below are not met, the unit must not be put back into operation until it has been repaired and tested again.

Repair and maintenance work may only be performed by qualified authorised personnel; otherwise the right to claim under warranty is void. In all service matters, always consult the dealer who supplied the machine. Return deliveries of defective equipment subject to warranty may only be made through your dealer. When replacing parts, use only original spare parts. When ordering spare parts, please quote the machine type, serial number and item number of the machine, as well as the type designation and item number of the spare part.

The welding torch is one of the most stressed components of the welding system. Due to the high thermal load and contamination, regular maintenance and care not only extends the service life of the system but also saves costs in the long term through the use of fewer replacement parts and less downtime. Perfect welding results can only be achieved with a properly maintained welding torch.

For maintenance and care, use only the tools, aids and tightening torques specified in the operating instructions.

#### 6.1.1 Identifying damage or worn components

Contact tip

- Oval, ground bore at the wire outlet
- Clinging weld spatter that can no longer be removed
- Penetration or burn-off at the contact tip
- Contact tip that sits eccentrically

Gas nozzle

- Clinging weld spatter, deformation, notches, penetration and damaged threads
- The O-ring of the gas nozzle holder is worn (for water-cooled welding torches)

Gas diffuser

- Clogged bores, cracks, burnt-off outer edges

Contact tip holder

- The key flat is defective or worn, thread damaged, clinging weld spatter

Torch head

- The thread is defective or worn

## Euro torch connector

- The O-ring of the connecting nipple for shielding gas is defective or worn
- The spring pins of the torch trigger are bent, jammed or dirty
- The thread of the crown nut is dirty or damaged
- For water-cooled welding torches, check the coolant connections for damage

## Grip

- Cracks, penetration

## Hose package

- Cracks, penetration

**To prevent damage and malfunction of the welding torch:**

- **Never hit hard objects (hammering)!**
- **Do not use the welding torch for levering or straightening!**
- **Do not bend the torch neck! Bending flexible torch necks is possible considering the maximum bending cycles.**
- **During breaks or after work, place the welding torch in the torch holder provided on the welding machine or at the workplace!**
- **Never throw the welding torch!**
- **Do not pull welding machines / wire feeders with the welding torch!**

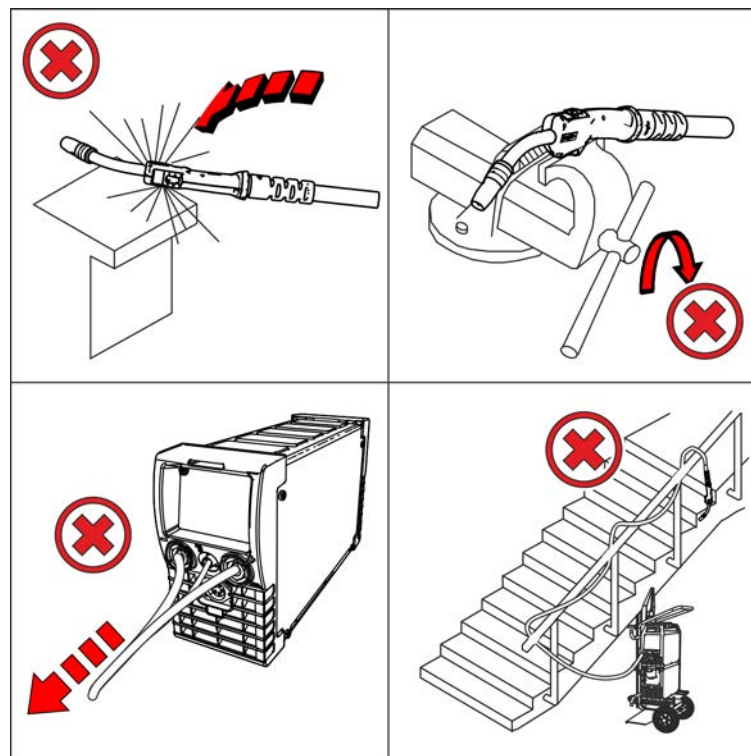

Figure 6-1

## 6.1.2 Maintenance and care before each use

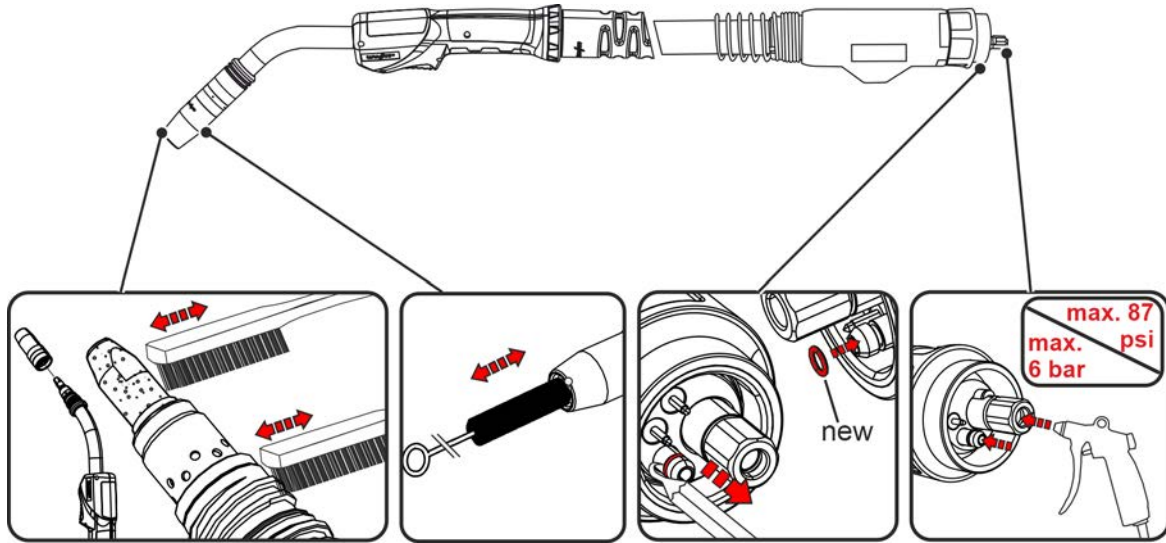

Figure 6-2

- Loosen the gas nozzle, check the replacement parts for damage, replace if necessary and ensure a tight fit.
- Clean and remove soiling and welding spatter from the welding torch and, particularly, the wear parts; replace any worn or defective parts, if necessary.
- Check the O-rings on the torch neck and Euro torch connector for damage and presence. Replace defective O-ring.
- With water-cooled welding torches, check the coolant connections for tightness and flow. Check the coolant fill level at the cooling unit.
- Check the grip and hose package for cracks and damage.

### 6.1.3 Regular maintenance

The regular maintenance of a welding torch depends heavily on the duration of use and the stress and must be specified by the operator / owner. As a rule of thumb, every time the wire spool or wire basket is replaced or, if necessary, at a change of shift.

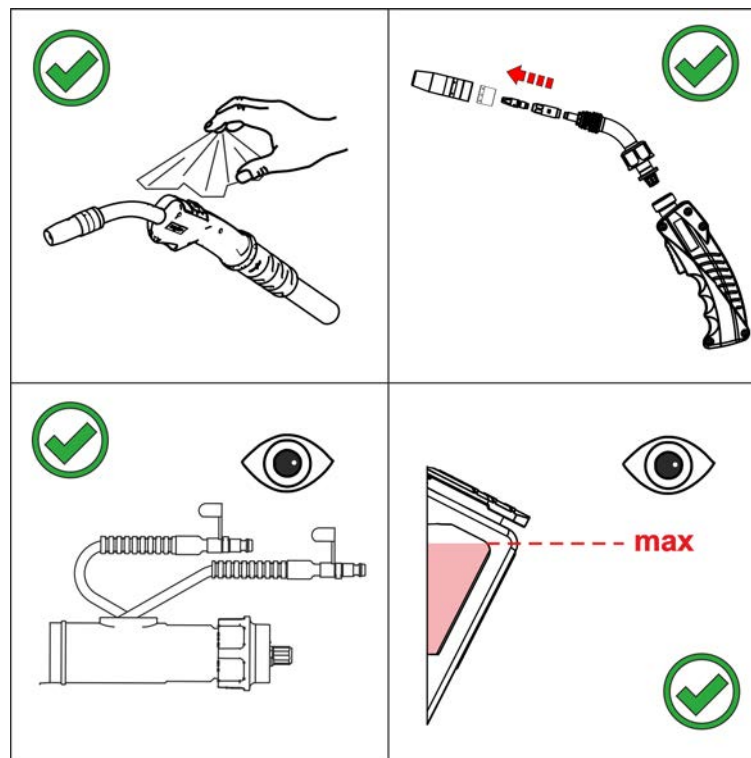

Figure 6-3

- Disconnect the welding torch from the machine, remove the replacement parts and blow out the wire duct and gas connection of the torch alternately with compressed air (max. 4 bar) free of oil and condensed water.
- Mount the replacement parts, connect the welding torch to the machine and purge twice with shielding gas (gas test).
- Check the liner or steel liner for damage and replace if necessary.
- Check the coolant container for sludge deposits and check the coolant for cloudiness. Clean the coolant container if contaminated, and change the coolant.
- If the coolant is dirty, rinse through the welding torch alternately several times with fresh coolant using the coolant return and supply.
- Check the screw and plug connectors of connections for proper seating and tighten if necessary.

## 6.2 Disposing of equipment



### Proper disposal!

The machine contains valuable raw materials, which should be recycled, and electronic components, which must be disposed of.

- **Do not dispose of in household waste!**
- **Observe the local regulations regarding disposal!**
- According to European provisions (Directive 2012/19/EU on Waste of Electrical and Electronic Equipment), used electric and electronic equipment may no longer be placed in unsorted municipal waste. It must be collected separately. The symbol depicting a waste container on wheels indicates that the equipment must be collected separately.  
This machine has to be disposed of, or recycled, in accordance with the waste separation systems in use.

According to German law (law governing the distribution, taking back and environmentally correct disposal of electrical and electronic equipment (ElektroG)), used machines are to be placed in a collection system separate from unsorted municipal waste. The public waste management utilities (communities) have created collection points at which used equipment from private households can be disposed of free of charge.

The deletion of personal data is the responsibility of the end user.

Lamps, batteries or accumulators must be removed and disposed of separately before disposing of the device. The type of battery or accumulator and its composition is marked on the top (type CR2032 or SR44). The following EWM products may contain batteries or accumulators:

- **Welding helmets**  
Batteries or accumulators are easy to remove from the LED cassette.
- **Device controls**  
Batteries or accumulators are located on the back of these in corresponding sockets on the circuit board and are easy to remove. The controls can be removed using standard tools.

Information on returning used equipment or collections can be obtained from the respective municipal administration office. Devices can also be returned to EWM sales partners across Europe.

Further information on the topic of the disposal of electrical and electronic equipment can be found on our website at: <https://www.ewm-group.com/de/nachhaltigkeit.html>.

## 7 Rectifying faults

All products are subject to rigorous production checks and final checks. If, despite this, something fails to work at any time, please check the product using the following flowchart. If none of the fault rectification procedures described leads to the correct functioning of the product, please inform your authorised dealer.

### 7.1 Checklist for rectifying faults

**The correct machine equipment for the material and process gas in use is a fundamental requirement for perfect operation!**

Legend	Symbol	Description
	↗	Fault/Cause
	✘	Remedy

#### **Welding torch overheated**

- ↗ Insufficient coolant flow
  - ✘ Check coolant flow rate
  - ✘ Check coolant level and refill if necessary
  - ✘ Eliminate kinks in conduit system (hose packages)
  - ✘ Vent coolant circuit > see 7.2 chapter
- ↗ Loose welding current connections
  - ✘ Tighten power connections on the torch and/or on the workpiece
  - ✘ Screw contact tip holder and gas nozzle tightly into place correctly
- ↗ Overload
  - ✘ Check and correct welding current setting
  - ✘ Use a more powerful welding torch

#### **Functional error with the welding torch operating elements**

- ↗ Connection problems
  - ✘ Make control lead connections and check that they are fitted correctly.
  - ✘ Check the control line connections for damage.

## Wire feed problems

- ✓ Unsuitable or worn welding torch equipment
  - ✘ Adjust contact tip to wire diameter and -material and replace if necessary
  - ✘ Adjust wire guide to material in use, blow through and replace if necessary
- ✓ Kinked hose packages
  - ✘ Extend and lay out the torch hose package
- ✓ Incompatible parameter settings
  - ✘ Check settings and correct if necessary
- ✓ Contact tip blocked
  - ✘ Clean and, if necessary, replace.
- ✓ Setting the spool brake
  - ✘ Check settings and correct if necessary
- ✓ Setting pressure units
  - ✘ Check settings and correct if necessary
- ✓ Worn wire rolls
  - ✘ Check and replace if necessary
- ✓ Wire feed motor without supply voltage (automatic cutout triggered by overloading)
  - ✘ Reset triggered fuse (rear of the power source) by pressing the key button
- ✓ Wire guide core or spiral is dirty or worn
  - ✘ Clean core or spiral; replace kinked or worn cores
- ✓ Arc between gas nozzle and workpiece (metal vapour on the gas nozzle)
  - ✘ Replace gas nozzle
  - ✘ Clean the gas nozzle, contact tip, contact tip holder and gas diffuser and replace if they are worn.

## Unstable arc

- ✓ Unsuitable or worn welding torch equipment
  - ✘ Adjust contact tip to wire diameter and -material and replace if necessary
  - ✘ Adjust wire guide to material in use, blow through and replace if necessary
- ✓ Incompatible parameter settings
  - ✘ Check settings and correct if necessary

## Pore formation

- ✓ Inadequate or missing gas shielding
  - ✘ Check shielding gas setting and replace shielding gas cylinder if necessary
  - ✘ Shield welding site with protective screens (draughts affect the welding result)
  - ✘ Use gas lens for aluminium applications and high-alloy steels
  - ✘ Check the O-rings on the Euro torch connector and torch neck and replace them if necessary.
- ✓ Unsuitable or worn welding torch equipment
  - ✘ Check size of gas nozzle and replace if necessary
- ✓ Condensation in the gas tube
  - ✘ Purge hose package with gas or replace
  - ✘ Check the O-rings on the Euro torch connector and torch neck and replace them if necessary.
- ✓ Splashes in the gas nozzle
- ✓ Gas distributor out of order or missing



## 7.2 Vent coolant circuit

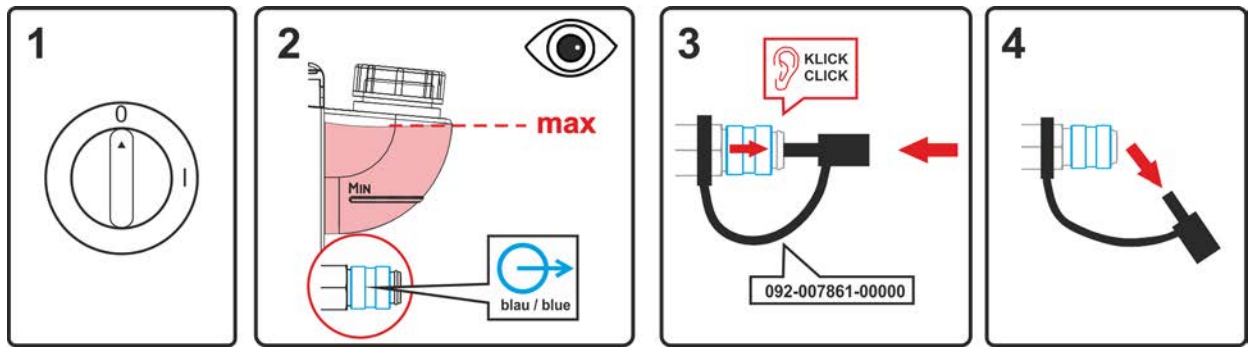

Figure 7-1

- Switch off the machine and fill the coolant tank to the maximum level.
- Unlock the quick-connect coupling with a suitable tool (connection open).

**To vent the cooling system always use the blue coolant connection, which is located as deep as possible inside the system (close to the coolant tank)!**

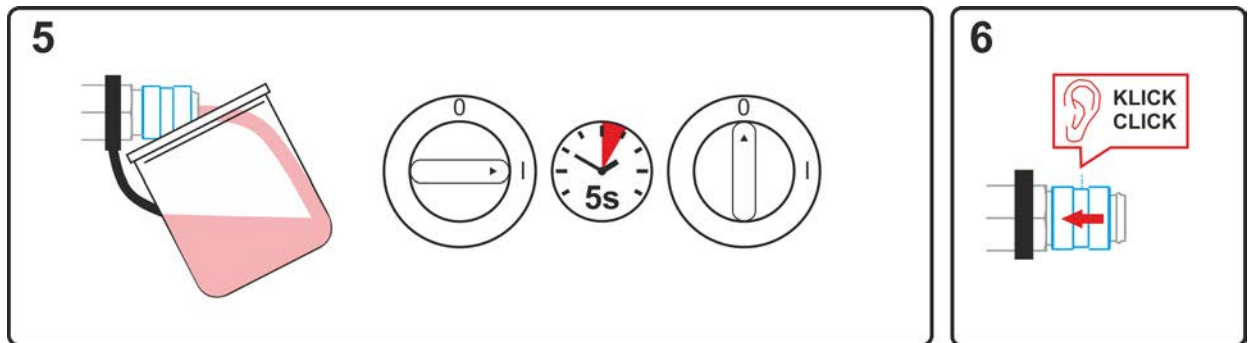

Figure 7-2

- Position a suitable collection container for collecting the escaping coolant at the quick-connect coupling and switch on the machine for approx. 5s.
- Lock the quick-connect coupling by pushing back the locking ring.

## 8 Technical data

### 8.1 UM 15 G, -24 G, -25 G, -36 G

Performance specifications and guarantee only in connection with original spare and replacement parts!

Typ	-15 G	-24 G	-25 G	-36 G
Welding torch polarity	Usually positive			
Guide type	Manually operated			
Voltage type	Direct voltage			
Shielding gas	CO <sub>2</sub> or mixed gas M21 according to DIN EN ISO			
Duty cycle DC at 40° C <sup>[1]</sup>	60 %			
Maximum welding current M21	150 A	220 A	200 A	270 A
Maximum welding current CO <sub>2</sub>	180 A	250 A	230 A	300 A
Switching voltage Push-button	42 V			
Switching current Push-button	10 mA			
Wire types	Standard round wires			
Wire diameter	0,6 to 1,0 mm	0,6 to 1,2 mm		0,8 to 1,4 mm
Ambient temperature	-25 °C to + 55 °C			
Voltage measurement	113 V Peak value			
Protection classification for the machine connections (EN 60529)	IP3X			
Gas flow	10 to 18 l/min			10 to 20 l/min
Hose package length	3-, 4-, 5- m			
Connection	Euro torch connector			
Test mark	CE / EAC / UK			
Standards used	See declaration of conformity (appliance documents)			
Operating weight	0,64 kg	0,95 kg	0,9 kg	1,34 kg

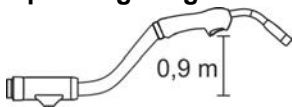

<sup>[1]</sup> Load cycle: 10 min. (60 % DC  $\triangleq$  6 min. welding, 4 min. pause)

## 8.2 UM 240 W, -401 W, -501 W

Performance specifications and guarantee only in connection with original spare and replacement parts!

Typ	-240 W	-401 W	-501 W
Welding torch polarity	Usually positive		
Guide type	Manually operated		
Voltage type	Direct voltage		
Shielding gas	CO <sub>2</sub> or mixed gas M21 according to DIN EN ISO		
Duty cycle DC at 40° C <sup>[1]</sup>	100 %		
Maximum welding current M21	270 A	350 A	450 A
Maximum welding current CO <sub>2</sub>	300 A	400 A	500 A
Switching voltage Push-button	42 V		
Switching current Push-button	10 mA		
Cooling capacity	min. 800 W		
max. Flow temperature	40 °C		
max. Coolant conductance	350 µS/cm		
Torch input pressure, coolant	2,5 to 3,5 bar (min.-max.)		
Flow volume min.	1,0 l/min		
Wire types	Standard round wires		
Wire diameter	0,6 to 1,2 mm	0,8 to 1,6 mm	0,8 to 1,6 mm
Ambient temperature	-25 °C to + 55 °C		
Voltage measurement	113 V Peak value		
Protection classification for the machine connections (EN 60529)	IP3X		
Gas flow	10 to 20 l/min		
Hose package length	3-, 4-, 5 m		
Connection	Euro torch connector		
Test mark	CE / EAC / UK		
Standards used	See declaration of conformity (appliance documents)		
Operating weight	1,03 kg	1,14 kg	1,18 kg

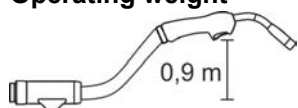

<sup>[1]</sup> Load cycle: 10 min. (60 % DC  $\triangleq$  6 min. welding, 4 min. pause)

## 9 Accessories

### 9.1 List of tools

Type	Designation	Item no.
Cutter	Hose cutter	094-016585-00000
DSP	Sharpener for liner	094-010427-00000
SW5-SW12MM	Torch key	094-016038-00001
O-Ring Picker	O-ring picker	098-005149-00000
CBB Ø 15 mm	Cylinder brushes, brass wire 15mm	098-005208-00000
CBB Ø 20 mm	Cylinder brushes, brass wire 20mm	098-005209-00000
3 x 5/6	Spark plug brush	098-004718-00000

### 9.2 General accessories

Type	Designation	Item no.
ADAP CZA	Adapter for welding torches from Euro torch connector to CLOOS connector (gas/water on the outside)	094-019852-00000
ADAP EZA/DZA	Adapter for welding torches from Euro torch connector to DINSE connector on the machine	394-000134-00000

### 9.3 Welding torch cooling system

Type	Designation	Item no.
HOSE BRIDGE UNI	Tube bridge	092-007843-00000

#### 9.3.1 Coolant - type blueCool

Type	Designation	Item no.
blueCool -10 5 l	Coolant up to -10 °C (14 °F), 5 l	094-024141-00005
blueCool -10 25 l	Coolant up to -10 °C (14 °F), 25 l	094-024141-00025
blueCool -30 5 l	Coolant up to -30 °C (22 °F), 5 l	094-024142-00005
blueCool -30 25 l	Coolant up to -30 °C (22 °F), 25 l	094-024142-00025
FSP blueCool	Frost protection tester	094-026477-00000

#### 9.3.2 Coolant - type KF

Type	Designation	Item no.
KF 23E-5	Coolant up to -10 °C (14 °F), 5 l	094-000530-00005
KF 23E-200	Coolant (-10 °C), 200 litres	094-000530-00001
KF 37E-5	Coolant up to -20 °C (4 °F), 5 l	094-006256-00005
KF 37E-200	Coolant (-20 °C), 200 l	094-006256-00001
TYP1	Frost protection tester	094-014499-00000

## 10 Replaceable parts



**The manufacturer's warranty becomes void if non-genuine parts are used!**

- Only use system components and options (power sources, welding torches, electrode holders, remote controls, spare parts and replacement parts, etc.) from our range of products!
- Only insert and lock accessory components into the relevant connection socket when the machine is switched off.

### 10.1 UM 15 G

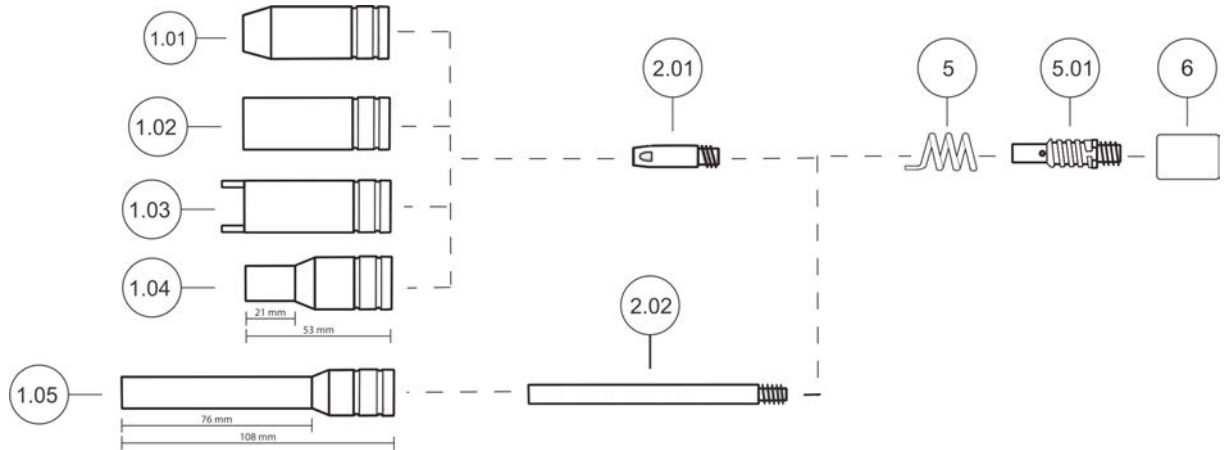

Figure 10-1

Item	Order number	Type	Description
-	394-000469-00000	TTOOL MHS	Centring tool for narrow-gap contact tip
1.01	394-000472-00000	GN Eco Ø=12mm L=53mm UM 15	Gas nozzle, conical
1.01	394-001212-00000	GN Eco Ø=9,5mm L=53mm UM 15	Gas nozzle, highly conical
1.02	394-000211-00000	GN Eco Ø=16mm L=53mm UM 15	Gas nozzle cylindrical
1.03	394-000213-00000	PGD UM15	Spot welding nozzle, plug fitting
1.04	394-002526-00000	SGN 53mm, Ø=10mm	Narrow-gap gas nozzle with cylinder, plug fitting
1.05	394-000212-00000	SGN 108 mm, Ø=10 mm	Narrow-gap gas nozzle with cylinder, plug fitting
2.01	394-001086-00000	CT Eco M6x25 E-Cu Ø=1.0 mm	Contact tip
2.01	394-001087-00000	CT Eco M6x25 E-Cu Ø=0.8mm	Contact tip
2.01	394-003654-00000	CT Eco M6x25 E-Cu Ø=0.6mm	Contact tip
2.02	394-000707-00000	CT M6-L83-AD6 0.8-1.0	Narrow-gap contact tip
5	094-023061-00000	CTH UM 15	Retaining spring
5.01	094-023060-00000	CTH UM 15	Contact tip holder
6	094-023552-00000	18 mm x 15 mm	Stop ring

## 10.2 UM 24 G

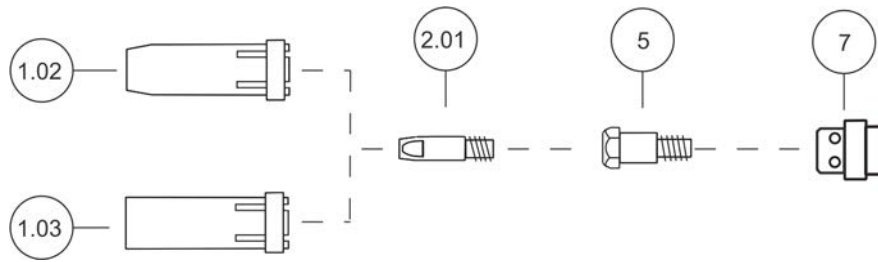

Figure 10-2

Item	Order number	Type	Description
1.02	394-000361-00000	GN Eco Ø=12,5mm L=63,5mm UM 24/240	Gas nozzle, conical
1.02	394-001234-00000	GN Eco Ø=10mm L=63,5mm UM 24/240	Gas nozzle, highly conical
1.03	394-000362-00000	GN Eco Ø=17mm L=63,5mm UM 24/240	Gas nozzle cylindrical
2.01	394-001191-00000	CT Eco M6 E-Cu Ø=0.8mm	Contact tip
2.01	394-001228-00000	CT Eco M6 E-Cu Ø=1.0mm	Contact tip
2.01	394-001229-00000	CT Eco M6 E-Cu Ø=1.2mm	Contact tip
2.01	394-003339-00000	CT Eco M6x28 CuCrZr Ø=1mm	Contact tip
2.01	394-005224-00000	CT Eco M6x28 CuCrZr Ø=1.2mm	Contact tip
2.01	394-005407-00000	CT Eco M6x28 CuCrZr Ø=0.8mm	Contact tip
2.01	394-016105-00000	CT Eco M6x28 E-Cu Ø=0,8mm Alu	Contact tip, aluminium welding
2.01	394-016107-00000	CT Eco M6x28 E-Cu Ø=1,0mm Alu	Contact tip, aluminium welding
2.01	394-016108-00000	CT Eco M6x28 E-Cu Ø=1,2mm Alu	Contact tip, aluminium welding
5	394-000363-00000	CTH Eco M6x26mm UM 24/240	Contact tip holder
7	394-000360-00000	GD Eco L=20 mm, UM 24/240	Gas diffuser

**10.3 UM 25 G**

Figure 10-3

Item	Order number	Type	Description
1.02	394-000369-00000	GN Eco Ø=15mm L=57mm UM 25	Gas nozzle, conical
1.02	394-001647-00000	GN Eco Ø=11,5mm L=57mm UM 25	Gas nozzle, highly conical
1.03	394-000371-00000	GN Eco Ø=18mm L=57mm UM 25	Gas nozzle cylindrical
1.04	394-000373-00000	PGD UM 25	Spot welding nozzle
2.01	394-000447-00000	CT Eco M8x30 E-Cu Ø=0.8mm	Contact tip
2.01	394-000450-00000	CT Eco M8x30 CuCrZr Ø=1mm	Contact tip
2.01	394-000452-00000	CT Eco M8x30 CuCrZr Ø=1.2mm	Contact tip
2.01	394-000941-00000	CT Eco M8x30 E-Cu Ø=1mm	Contact tip
2.01	394-000942-00000	CT Eco M8x30 E-Cu Ø=1.2mm	Contact tip
2.01	394-001191-00000	CT Eco M6 E-Cu Ø=0.8mm	Contact tip
2.01	394-001228-00000	CT Eco M6 E-Cu Ø=1.0mm	Contact tip
2.01	394-001229-00000	CT Eco M6 E-Cu Ø=1.2mm	Contact tip
2.01	394-003339-00000	CT Eco M6x28 CuCrZr Ø=1mm	Contact tip
2.01	394-005224-00000	CT Eco M6x28 CuCrZr Ø=1.2mm	Contact tip
2.01	394-005407-00000	CT Eco M6x28 CuCrZr Ø=0.8mm	Contact tip
2.01	394-014024-00000	CT Eco M8x30 CuCrZr Ø=0.8mm	Contact tip
2.01	394-016105-00000	CT Eco M6x28 E-Cu Ø=0,8mm Alu	Contact tip, aluminium welding
2.01	394-016107-00000	CT Eco M6x28 E-Cu Ø=1,0mm Alu	Contact tip, aluminium welding
2.01	394-016108-00000	CT Eco M6x28 E-Cu Ø=1,2mm Alu	Contact tip, aluminium welding
2.01	394-016115-00000	CT Eco M8x30 E-Cu Ø=0,8mm Alu	Contact tip, aluminium welding
2.01	394-016117-00000	CT Eco M8x30 E-Cu Ø=1,0mm Alu	Contact tip, aluminium welding
2.01	394-016118-00000	CT Eco M8x30 E-Cu Ø=1,2mm Alu	Contact tip, aluminium welding
5	394-000375-00000	CTH M8x35mm UM 25	Contact tip holder
5	394-001823-00000	CTH Eco M6x35mm UM 25	Contact tip holder
5.01	394-003656-00000	HF UM 25	Retaining spring

## 10.4 UM 36 G

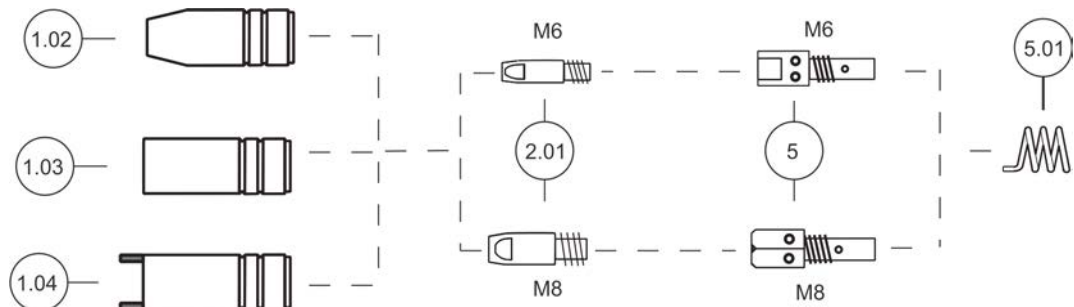
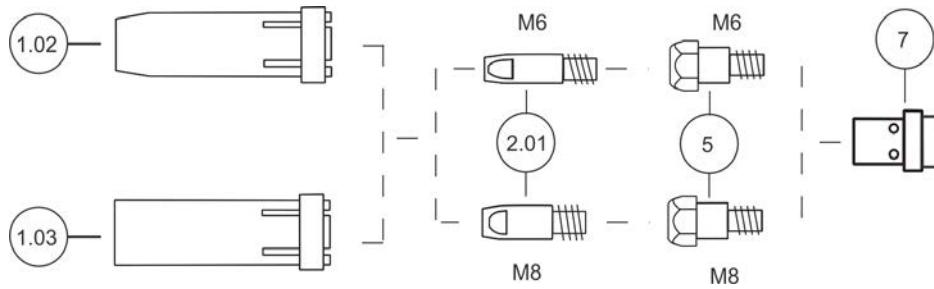

Figure 10-4

Item	Order number	Type	Description
1.02	394-000431-00000	GN Eco Ø=16mm L=84mm UM 36	Gas nozzle, conical
1.02	394-001241-00000	GN Eco Ø=12mm L=84mm UM 36	Gas nozzle, highly conical
1.03	394-000432-00000	GN Eco Ø=19mm L=84mm UM 36	Gas nozzle cylindrical
2.01	394-000447-00000	CT Eco M8x30 E-Cu Ø=0.8mm	Contact tip
2.01	394-000450-00000	CT Eco M8x30 CuCrZr Ø=1mm	Contact tip
2.01	394-000452-00000	CT Eco M8x30 CuCrZr Ø=1.2mm	Contact tip
2.01	394-000455-00000	CT Eco M8x30 CuCrZr Ø=1.4mm	Contact tip
2.01	394-000941-00000	CT Eco M8x30 E-Cu Ø=1mm	Contact tip
2.01	394-000942-00000	CT Eco M8x30 E-Cu Ø=1.2mm	Contact tip
2.01	394-001191-00000	CT Eco M6 E-Cu Ø=0.8mm	Contact tip
2.01	394-001228-00000	CT Eco M6 E-Cu Ø=1.0mm	Contact tip
2.01	394-001229-00000	CT Eco M6 E-Cu Ø=1.2mm	Contact tip
2.01	394-003339-00000	CT Eco M6x28 CuCrZr Ø=1mm	Contact tip
2.01	394-005224-00000	CT Eco M6x28 CuCrZr Ø=1.2mm	Contact tip
2.01	394-005407-00000	CT Eco M6x28 CuCrZr Ø=0.8mm	Contact tip
2.01	394-014024-00000	CT Eco M8x30 CuCrZr Ø=0.8mm	Contact tip
2.01	394-016105-00000	CT Eco M6x28 E-Cu Ø=0,8mm Alu	Contact tip, aluminium welding
2.01	394-016107-00000	CT Eco M6x28 E-Cu Ø=1,0mm Alu	Contact tip, aluminium welding
2.01	394-016108-00000	CT Eco M6x28 E-Cu Ø=1,2mm Alu	Contact tip, aluminium welding
2.01	394-016115-00000	CT Eco M8x30 E-Cu Ø=0,8mm Alu	Contact tip, aluminium welding
2.01	394-016117-00000	CT Eco M8x30 E-Cu Ø=1,0mm Alu	Contact tip, aluminium welding
2.01	394-016118-00000	CT Eco M8x30 E-Cu Ø=1,2mm Alu	Contact tip, aluminium welding
5	394-000433-00000	CTH Eco M6x28mm UM 36	Contact tip holder
5	394-000434-00000	CTH Eco M8x28mm UM 36	Contact tip holder
7	394-012572-00000	GD L=32 mm UM 36	Gas diffuser



**10.5 UM 240 W**

Figure 10-5

Item	Order number	Type	Description
1.02	394-000361-00000	GN Eco Ø=12,5mm L=63,5mm UM 24/240	Gas nozzle, conical
1.02	394-001234-00000	GN Eco Ø=10mm L=63,5mm UM 24/240	Gas nozzle, highly conical
1.03	394-000362-00000	GN Eco Ø=17mm L=63,5mm UM 24/240	Gas nozzle cylindrical
2.01	394-001191-00000	CT Eco M6 E-Cu Ø=0.8mm	Contact tip
2.01	394-001228-00000	CT Eco M6 E-Cu Ø=1.0mm	Contact tip
2.01	394-001229-00000	CT Eco M6 E-Cu Ø=1.2mm	Contact tip
2.01	394-003339-00000	CT Eco M6x28 CuCrZr Ø=1mm	Contact tip
2.01	394-005224-00000	CT Eco M6x28 CuCrZr Ø=1.2mm	Contact tip
2.01	394-005407-00000	CT Eco M6x28 CuCrZr Ø=0.8mm	Contact tip
2.01	394-016105-00000	CT Eco M6x28 E-Cu Ø=0,8mm Alu	Contact tip, aluminium welding
2.01	394-016107-00000	CT Eco M6x28 E-Cu Ø=1,0mm Alu	Contact tip, aluminium welding
2.01	394-016108-00000	CT Eco M6x28 E-Cu Ø=1,2mm Alu	Contact tip, aluminium welding
5	394-000363-00000	CTH Eco M6x26mm UM 24/240	Contact tip holder
7	394-000360-00000	GD Eco L=20 mm, UM 24/240	Gas diffuser

## 10.6 UM 401 W / UM 501 W

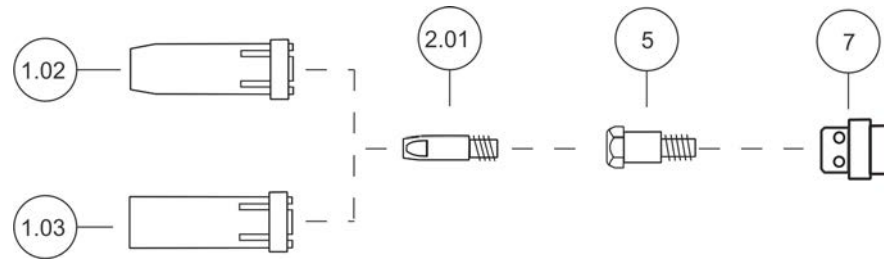
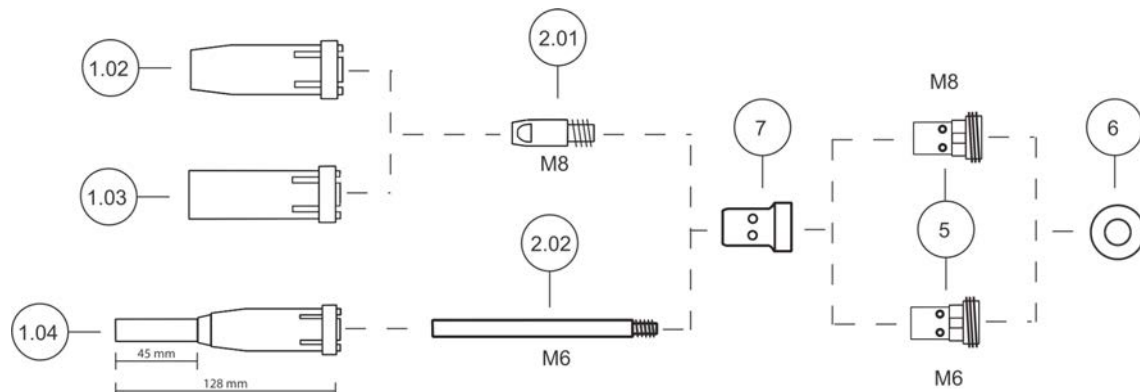

Figure 10-6

Item	Order number	Type	Description
-	394-000469-00000	TTOOL MHS	Centring tool for narrow-gap contact tip
1.02	394-000435-00000	GN Eco Ø=16mm L=76mm UM 401/501	Gas nozzle, conical
1.02	394-000436-00000	GN Eco Ø=14mm L=76mm UM 401/501	Gas nozzle, highly conical
1.03	394-000437-00000	GN Eco Ø=19mm L=76mm UM 401/501	Gas nozzle cylindrical
1.04	394-000711-00000	SGN 128 mm, Ø=11 mm	Narrow-gap gas nozzle
2.01	394-000447-00000	CT Eco M8x30 E-Cu Ø=0.8mm	Contact tip
2.01	394-000450-00000	CT Eco M8x30 CuCrZr Ø=1mm	Contact tip
2.01	394-000452-00000	CT Eco M8x30 CuCrZr Ø=1.2mm	Contact tip
2.01	394-000456-00000	CT Eco M8x30 E-Cu Ø=1.6mm	Contact tip
2.01	394-000458-00000	CT Eco M8x30 CuCrZr Ø=1.6mm	Contact tip
2.01	394-000941-00000	CT Eco M8x30 E-Cu Ø=1mm	Contact tip
2.01	394-000942-00000	CT Eco M8x30 E-Cu Ø=1.2mm	Contact tip
2.01	394-014024-00000	CT Eco M8x30 CuCrZr Ø=0.8mm	Contact tip
2.01	394-016115-00000	CT Eco M8x30 E-Cu Ø=0,8mm Alu	Contact tip, aluminium welding
2.01	394-016117-00000	CT Eco M8x30 E-Cu Ø=1,0mm Alu	Contact tip, aluminium welding
2.01	394-016118-00000	CT Eco M8x30 E-Cu Ø=1,2mm Alu	Contact tip, aluminium welding
2.01	394-016120-00000	CT Eco M8x30 E-Cu Ø=1,6mm Alu	Contact tip, aluminium welding
2.02	394-000707-00000	CT M6-L83-AD6 0.8-1.0	Narrow-gap contact tip
2.02	394-003059-00000	CT M6 L83 1.2 E-Cu	Narrow-gap contact tip
5	394-000438-00000	CTH Eco M8x25mm UM 401/501	Contact tip holder
5	394-000439-00000	CTH M6x25mm	Contact tip holder
6	394-000761-00000	ISO UM 401/501 Eco	Insulating disk
7	394-000948-00000	GD Eco L=28 mm, UM 401/501	Gas diffuser
7	394-011628-00000	GD Eco Longlife UM 401/501	Gas diffuser, long life

## 11 Appendix

### 11.1 Searching for a dealer

Sales & service partners  
[www.ewm-group.com/en/specialist-dealers](http://www.ewm-group.com/en/specialist-dealers)



"More than 400 EWM sales partners worldwide"