



EN

Welding machine

Pico 160

Pico 160 VRD AUS

099-002128-EW501

Observe additional system documents!

18.09.2023

**Register now
and benefit!
Jetzt Registrieren
und Profitieren!**

www.ewm-group.com



General instructions

WARNING



Read the operating instructions!

The operating instructions provide an introduction to the safe use of the products.

- Read and observe the operating instructions for all system components, especially the safety instructions and warning notices!
- Observe the accident prevention regulations and any regional regulations!
- The operating instructions must be kept at the location where the machine is operated.
- Safety and warning labels on the machine indicate any possible risks. Keep these labels clean and legible at all times.
- The machine has been constructed to state-of-the-art standards in line with any applicable regulations and industrial standards. Only trained personnel may operate, service and repair the machine.
- Technical changes due to further development in machine technology may lead to a differing welding behaviour.

In the event of queries on installation, commissioning, operation or special conditions at the installation site, or on usage, please contact your sales partner or our customer service department on +49 2680 181-0.

A list of authorised sales partners can be found at www.ewm-group.com/en/specialist-dealers.

Liability relating to the operation of this equipment is restricted solely to the function of the equipment. No other form of liability, regardless of type, shall be accepted. This exclusion of liability shall be deemed accepted by the user on commissioning the equipment.

The manufacturer is unable to monitor whether or not these instructions or the conditions and methods are observed during installation, operation, usage and maintenance of the equipment.

An incorrectly performed installation can result in material damage and injure persons as a result. For this reason, we do not accept any responsibility or liability for losses, damages or costs arising from incorrect installation, improper operation or incorrect usage and maintenance or any actions connected to this in any way.

© EWM GmbH

Dr. Günter-Henle-Strasse 8

56271 Mündersbach Germany

Tel.: +49 2680 181-0, Fax: -244

Email: info@ewm-group.com

www.ewm-group.com

The copyright to this document remains the property of the manufacturer.

Copying, including extracts, only permitted with written approval.

The content of this document has been prepared and reviewed with all reasonable care. The information provided is subject to change; errors excepted.

Data security

The user is responsible for backing up data of all changes from the factory setting. The user is liable for erased personal settings. The manufacturer does not assume any liability for this.

1 Contents

1	Contents	3
2	For your safety	6
2.1	Notes on using these operating instructions.....	6
2.2	Explanation of icons.....	7
2.3	Safety instructions.....	8
2.4	Transport and installation	11
3	Intended use	13
3.1	Applications.....	13
3.2	Documents which also apply	14
3.2.1	Warranty	14
3.2.2	Declaration of Conformity.....	14
3.2.3	Welding in environments with increased electrical hazards.....	14
3.2.4	Calibration/Validation	14
3.2.5	Part of the complete documentation.....	14
4	Machine description – quick overview	15
4.1	Front view	15
4.2	Rear view	16
4.3	Machine control – Operating elements	17
5	Design and function	18
5.1	Transport and installation	18
5.1.1	Machine cooling.....	18
5.1.2	Workpiece lead, general.....	18
5.1.3	Ambient conditions	19
5.1.4	Transport belt	19
5.1.4.1	Adjusting the length of the carrying strap	19
5.1.5	Notes on the installation of welding current leads.....	20
5.1.6	Stray welding currents.....	21
5.1.7	Mains connection.....	22
5.1.7.1	Mains configuration	22
5.2	MMA welding	23
5.2.1	Connecting the electrode holder and workpiece lead	23
5.2.2	Welding task selection.....	24
5.2.3	Hotstart	24
5.2.4	Arcforce	24
5.2.5	Antistick	24
5.3	TIG welding.....	25
5.3.1	Connecting a TIG welding torch with rotating gas valve	25
5.3.2	Shielding gas supply (shielding gas cylinder for welding machine)	25
5.3.2.1	Pressure regulator connection	26
5.3.3	Welding task selection.....	26
5.3.3.1	Gas test – setting the shielding gas volume	26
5.3.4	Arc ignition.....	27
5.3.4.1	Liftarc	27
5.4	Voltage reducing device	27
6	Maintenance, care and disposal	28
6.1	General	28
6.1.1	Cleaning	28
6.1.2	Dirt filter	28
6.2	Maintenance work, intervals	29
6.2.1	Daily maintenance tasks	29
6.2.2	Monthly maintenance tasks.....	29
6.2.3	Annual test (inspection and testing during operation).....	29
6.3	Disposing of equipment	30
7	Rectifying faults	31
7.1	Machine faults (error messages)	31
7.2	Checklist for rectifying faults	31

8	Technical data	33
8.1	Pico 160	33
9	Accessories	34
9.1	Electrode holder	34
9.2	Workpiece lead	34
9.3	Welding torch	34
9.4	Shielding gas supply (shielding gas cylinder for welding machine).....	34
9.5	Options	34
9.6	General accessories	34
10	Service documents	35
10.1	Spare and replacement parts.....	35
10.2	Circuit diagram	37
11	Appendix	38
11.1	Searching for a dealer.....	38

2 For your safety

2.1 Notes on using these operating instructions

DANGER

Working or operating procedures which must be closely observed to prevent imminent serious and even fatal injuries.

- Safety notes include the "DANGER" keyword in the heading with a general warning symbol.
- The hazard is also highlighted using a symbol on the edge of the page.

WARNING

Working or operating procedures which must be closely observed to prevent serious and even fatal injuries.

- Safety notes include the "WARNING" keyword in the heading with a general warning symbol.
- The hazard is also highlighted using a symbol in the page margin.

CAUTION

Working or operating procedures which must be closely observed to prevent possible minor personal injury.

- The safety information includes the "CAUTION" keyword in its heading with a general warning symbol.
- The risk is explained using a symbol on the edge of the page.



Technical aspects which the user must observe to avoid material or equipment damage.

Instructions and lists detailing step-by-step actions for given situations can be recognised via bullet points, e.g.:

- Insert the welding current lead socket into the relevant socket and lock.

2.2 Explanation of icons

Symbol	Description	Symbol	Description
	Indicates technical aspects which the user must observe.		Activate and release / Tap / Tip
	Switch off machine		Release
	Switch on machine		Press and hold
	Incorrect / Invalid		Switch
	Correct / Valid		Turn
	Input		Numerical value – adjustable
	Navigation		Signal light lights up in green
	Output		Signal light flashes green
	Time representation (e.g.: wait 4 s / actuate)		Signal light lights up in red
	Interruption in the menu display (other setting options possible)		Signal light flashes red
	Tool not required/do not use		Signal light lights up in blue
	Tool required/use		Signal light flashes blue

2.3 Safety instructions

WARNING



Risk of accidents due to non-compliance with the safety instructions!

Non-compliance with the safety instructions can be fatal!

- Carefully read the safety instructions in this manual!
- Observe the accident prevention regulations and any regional regulations!
- Inform persons in the working area that they must comply with the regulations!



Risk of injury from electrical voltage!

Voltages can cause potentially fatal electric shocks and burns on contact. Even low voltages can cause a shock and lead to accidents.

- Never touch live components such as welding current sockets or stick, tungsten or wire electrodes!
- Always place torches and electrode holders on an insulated surface!
- Wear the full personal protective equipment (depending on the application)!
- The machine may only be opened by qualified personnel!
- The device must not be used to defrost pipes!



Hazard when interconnecting multiple power sources!

If a number of power sources are to be connected in parallel or in series, only a technical specialist may interconnect the sources as per standard IEC 60974-9:2010: Installation and use and German Accident Prevention Regulation BVG D1 (formerly VBG 15) or country-specific regulations.

Before commencing arc welding, a test must verify that the equipment cannot exceed the maximum permitted open circuit voltage.

- Only qualified personnel may connect the machine.
- When taking individual power sources out of operation, all mains and welding current leads must be safely disconnected from the welding system as a whole. (Hazard due to reverse polarity voltage!)
- Do not interconnect welding machines with pole reversing switch (PWS series) or machines for AC welding since a minor error in operation can cause the welding voltages to be combined, which is not permitted.



Risk of injury due to radiation or heat!

Arc radiation can lead to skin and eye injuries.

Contact with hot workpieces and sparks can lead to burns.

- Use hand shield or welding helmet with the appropriate safety level (depends on the application).
- Wear dry protective clothing (e.g. hand shield, gloves, etc.) in accordance with the applicable regulations of your country.
- Persons who are not directly involved should be protected with a welding curtain or suitable safety screen against radiation and the risk of blinding!

 **WARNING****Risk of injury due to improper clothing!**

During arc welding, radiation, heat and voltage are sources of risk that cannot be avoided. The user has to be equipped with the complete personal protective equipment at all times. The protective equipment has to include:

- Respiratory protection against hazardous substances and mixtures (fumes and vapours); otherwise implement suitable measures such as extraction facilities.
- Welding helmet with proper protection against ionizing radiation (IR and UV radiation) and heat.
- Dry welding clothing (shoes, gloves and body protection) to protect against warm environments with conditions comparable to ambient temperatures of 100 °C or higher and arcing and work on live components.
- Hearing protection against harming noise.

**Explosion risk!**

Apparently harmless substances in closed containers may generate excessive pressure when heated.

- Move containers with inflammable or explosive liquids away from the working area!
- Never heat explosive liquids, dusts or gases by welding or cutting!

**Fire hazard!**

Due to the high temperatures, sparks, glowing parts and hot slag that occur during welding, there is a risk of flames.

- Be watchful of potential sources of fire in the working area!
- Do not carry any easily inflammable objects, e.g. matches or lighters.
- Ensure suitable fire extinguishers are available in the working area!
- Thoroughly remove any residue of flammable materials from the workpiece prior to starting to weld.
- Only further process workpieces after they have cooled down. Do not allow them to contact any flammable materials!

⚠ CAUTION



Smoke and gases!

Smoke and gases may lead to shortness of breath and poisoning! The ultraviolet radiation of the arc may also convert solvent vapours (chlorinated hydrocarbon) into poisonous phosgene.

- Ensure sufficient fresh air!
- Keep solvent vapours away from the arc beam field!
- Wear suitable respiratory protection if necessary!
- To prevent the formation of phosgene, residues of chlorinated solvents on workpieces must first be neutralised using appropriate measures.



Noise exposure!

Noise exceeding 70 dBA can cause permanent hearing damage!

- Wear suitable ear protection!
- Persons located within the working area must wear suitable ear protection!



According to IEC 60974-10, welding machines are divided into two classes of electromagnetic compatibility (the EMC class can be found in the Technical data) > see 8 chapter:



Class A machines are not intended for use in residential areas where the power supply comes from the low-voltage public mains network. When ensuring the electromagnetic compatibility of class A machines, difficulties can arise in these areas due to interference not only in the supply lines but also in the form of radiated interference.



Class B machines fulfil the EMC requirements in industrial as well as residential areas, including residential areas connected to the low-voltage public mains network.

Setting up and operating

When operating arc welding systems, in some cases, electro-magnetic interference can occur although all of the welding machines comply with the emission limits specified in the standard. The user is responsible for any interference caused by welding.

In order to **evaluate** any possible problems with electromagnetic compatibility in the surrounding area, the user must consider the following: (see also EN 60974-10 Appendix A)

- Mains, control, signal and telecommunication lines
- Radios and televisions
- Computers and other control systems
- Safety equipment
- The health of neighbouring persons, especially if they have a pacemaker or wear a hearing aid
- Calibration and measuring equipment
- The immunity to interference of other equipment in the surrounding area
- The time of day at which the welding work must be carried out

Recommendations for **reducing interference emission**

- Mains connection, e.g. additional mains filter or shielding with a metal tube
- Maintenance of the arc welding system
- Welding leads should be as short as possible and run closely together along the ground
- Potential equalization
- Earthing of the workpiece. In cases where it is not possible to earth the workpiece directly, it should be connected by means of suitable capacitors.
- Shielding from other equipment in the surrounding area or the entire welding system



Electromagnetic fields!

The power source can create electrical or electromagnetic fields that may impair the function of electronic systems such as EDP and CNC devices, telecommunication, power and signal lines as well as pacemakers and defibrillators.



- Follow the maintenance instructions > see 6.2 chapter!
- Unwind the welding leads completely!
- Shield radiation-sensitive equipment or facilities appropriately!
- The function of pacemakers may be impaired (seek medical advice if necessary).

⚠ CAUTION**Obligations of the operator!**

The respective national directives and laws must be complied with when operating the machine!

- Implementation of national legislation relating to framework directive 89/391/EEC on the introduction of measures to encourage improvements in the safety and health of workers at work and associated individual guidelines.
- In particular, directive 89/655/EEC concerning the minimum safety and health requirements for the use of work equipment by workers at work.
- The regulations applicable to occupational safety and accident prevention in the country concerned.
- Setting up and operating the machine as per IEC 60974.-9.
- Brief the user on safety-conscious work practices on a regular basis.
- Regularly inspect the machine as per IEC 60974.-4.



The manufacturer's warranty becomes void if non-genuine parts are used!

- ***Only use system components and options (power sources, welding torches, electrode holders, remote controls, spare parts and replacement parts, etc.) from our range of products!***
- ***Only insert and lock accessory components into the relevant connection socket when the machine is switched off.***

Requirements for connection to the public mains network

High-performance machines can influence the mains quality by taking current from the mains network. For some types of machines, connection restrictions or requirements relating to the maximum possible line impedance or the necessary minimum supply capacity at the interface with the public network (Point of Common Coupling, PCC) can therefore apply. In this respect, attention is also drawn to the machines' technical data. In this case, it is the responsibility of the operator, where necessary in consultation with the mains network operator, to ensure that the machine can be connected.

2.4 Transport and installation

⚠ WARNING**Risk of injury due to improper handling of shielding gas cylinders!**

Improper handling and insufficient securing of shielding gas cylinders can cause serious injuries!

- Observe the instructions from the gas manufacturer and any relevant regulations concerning the use of compressed air!
- Do not attach any element to the shielding gas cylinder valve!
- Prevent the shielding gas cylinder from heating up.

CAUTION



Risk of accidents due to supply lines!

During transport, attached supply lines (mains leads, control cables, etc.) can cause risks, e.g. by causing connected machines to tip over and injure persons!

- Disconnect all supply lines before transport!



Risk of tipping!

There is a risk of the machine tipping over and injuring persons or being damaged itself during movement and set up. Tilt resistance is guaranteed up to an angle of 10° (according to IEC 60974-1).

- Set up and transport the machine on level, solid ground.
- Secure add-on parts using suitable equipment.



Risk of accidents due to incorrectly installed leads!

Incorrectly installed leads (mains, control and welding leads or intermediate hose packages) can present a tripping hazard.

- Lay the supply lines flat on the floor (avoid loops).
- Avoid laying the leads on passage ways.



Risk of injury from heated coolant and its connections!

The coolant used and its connection or connection points can heat up significantly during operation (water-cooled version). When opening the coolant circuit, escaping coolant may cause scalding.

- Open the coolant circuit only when the power source or cooling unit is switched off!
- Wear proper protective equipment (protective gloves)!
- Seal open connections of the hose leads with suitable plugs.



The units are designed for operation in an upright position!

Operation in non-permissible positions can cause equipment damage.

- ***Only transport and operate in an upright position!***



Accessory components and the power source itself can be damaged by incorrect connection!

- ***Only insert and lock accessory components into the relevant connection socket when the machine is switched off.***
- ***Comprehensive descriptions can be found in the operating instructions for the relevant accessory components.***
- ***Accessory components are detected automatically after the power source is switched on.***



Protective dust caps protect the connection sockets and therefore the machine against dirt and damage.

- ***The protective dust cap must be fitted if there is no accessory component being operated on that connection.***
- ***The cap must be replaced if faulty or if lost!***

3 Intended use

WARNING



Hazards due to improper usage!

The machine has been constructed to the state of the art and any regulations and standards applicable for use in industry and trade. It may only be used for the welding procedures indicated at the rating plate. Hazards may arise for persons, animals and material objects if the equipment is not used correctly. No liability is accepted for any damages arising from improper usage!

- The equipment must only be used in line with its designated purpose and by trained or expert personnel!
- Do not improperly modify or convert the equipment!

3.1 Applications

Arc welding machine for MMA DC welding with TIG DC welding with lift arc (touch starting) as secondary process.

3.2 Documents which also apply

3.2.1 Warranty

For more information refer to the "Warranty registration" brochure supplied and our information regarding warranty, maintenance and testing at www.ewm-group.com!

3.2.2 Declaration of Conformity



This product corresponds in its design and construction to the EU directives listed in the declaration. The product comes with a relevant declaration of conformity in the original.

The manufacturer recommends carrying out the safety inspection according to national and international standards and guidelines every 12 months (from commissioning).

3.2.3 Welding in environments with increased electrical hazards



Power sources with this marking can be used for welding in an environment with increased electrical hazard (e.g. boilers). For this purpose, appropriate national or international regulations must be followed. The power source must not be placed in the danger zone!

3.2.4 Calibration/Validation

An original certificate is enclosed with the product. The manufacturer recommends calibration / validation at intervals of 12 months (from commissioning).

3.2.5 Part of the complete documentation

These operating instructions are part of the complete documentation and valid only in combination with the "Safety instructions"!

Read and observe the documents for all system components!

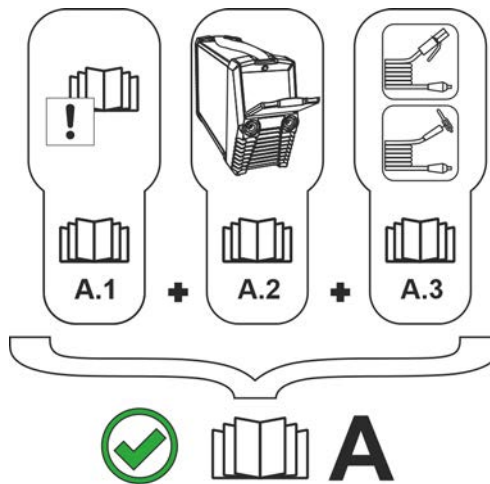

Figure 3-1

Item	Documentation
A.1	Safety instructions
A.2	Power source
A.3	Welding torch / Electrode holder
A	Complete documentation

4 Machine description – quick overview

4.1 Front view

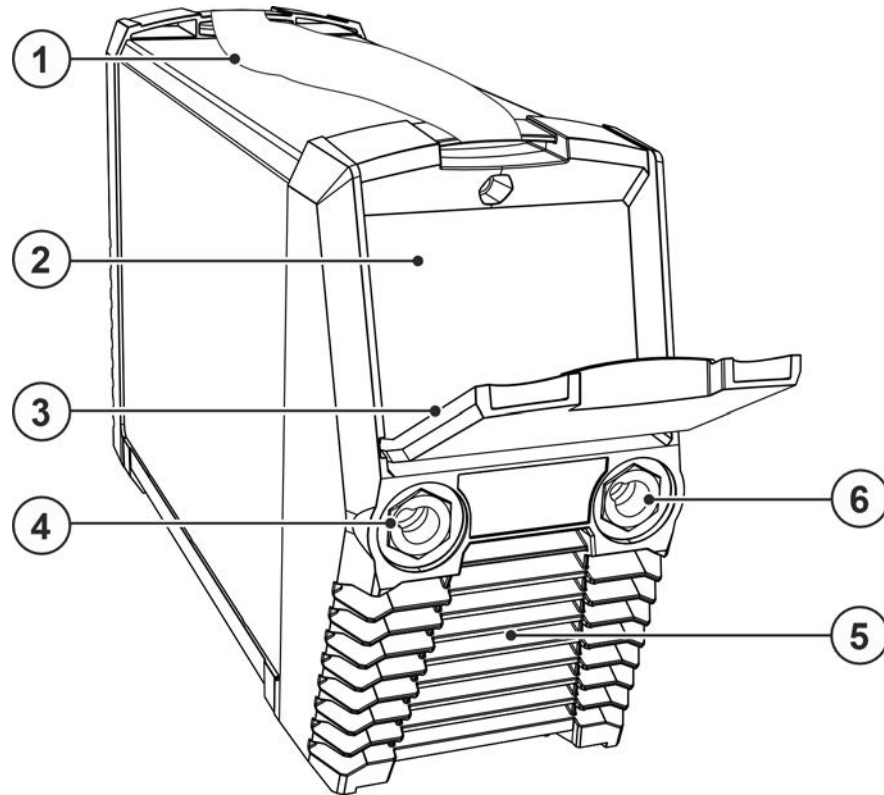

Figure 4-1

Item	Symbol	Description
1		Carrying strap > see 5.1.4.1 chapter
2		Machine control > see 4.3 chapter
3		Protective cap
4	+	Connection socket, "+" welding current <ul style="list-style-type: none"> • MMA: Electrode holder or workpiece lead connection • TIG: Connection for workpiece lead
5		Cooling air outlet
6	—	Connection socket, "-" welding current <ul style="list-style-type: none"> • MMA: Connection of electrode holder or workpiece lead • TIG: Connection of TIG welding torch

4.2 Rear view

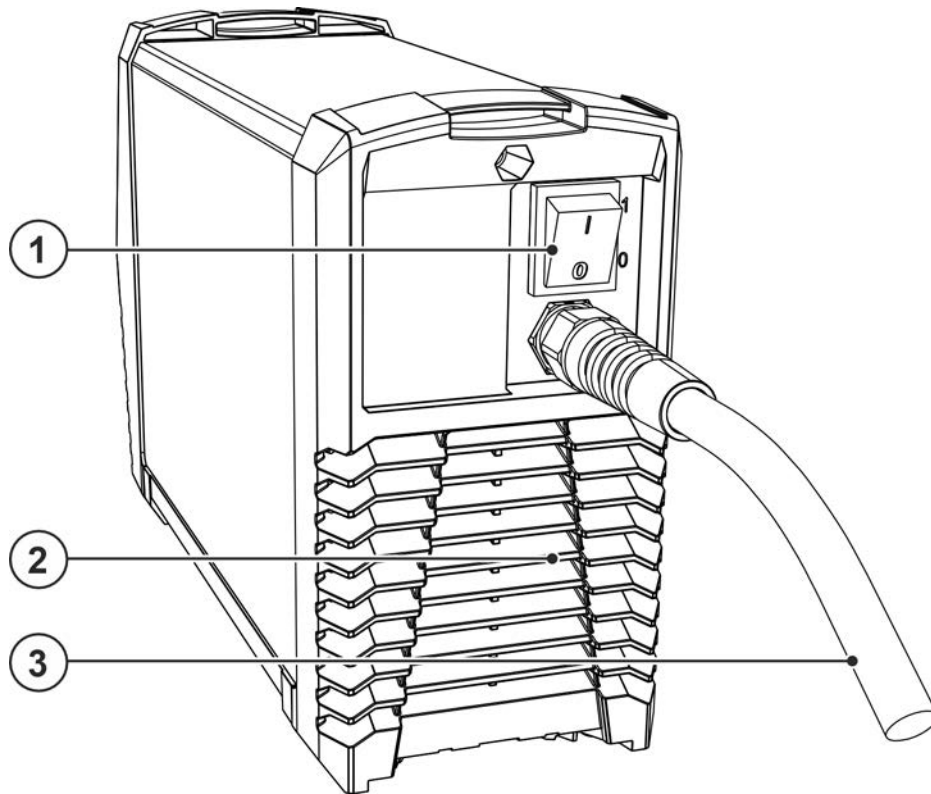

Figure 4-2

Item	Symbol	Description
1		Main Switch Switching the machine on or off.
2		Cooling air inlet
3		Mains connection cable > see 5.1.7 chapter

4.3 Machine control – Operating elements

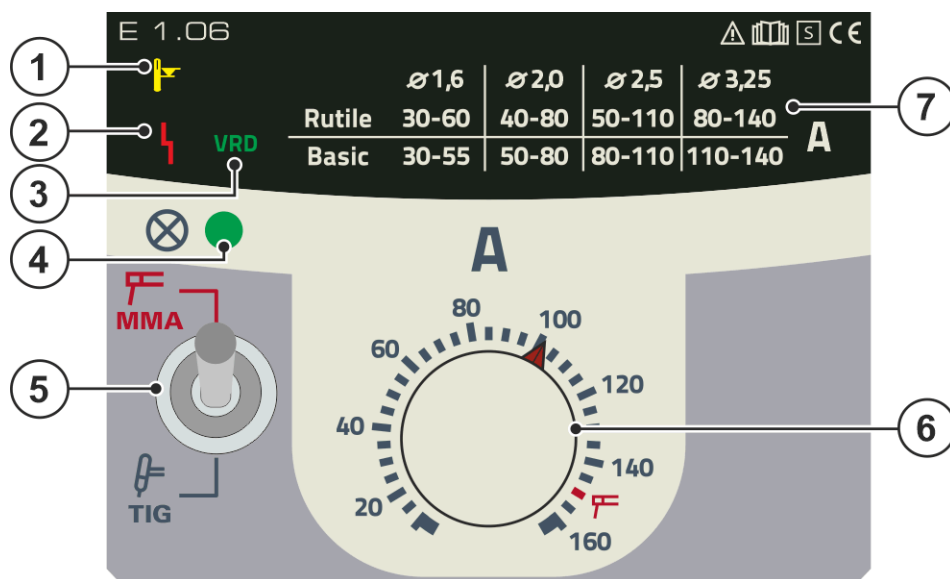

Figure 4-3

Item	Symbol	Description
1		Excess temperature signal light In case of excess temperature, temperature monitors de-activate the power unit, and the excess temperature control lamp comes on. Once the machine has cooled down, welding can continue without any further measures.
2		Collective interference signal light For error messages, > see 7 chapter
3	VRD	Voltage reduction device (VRD) signal light > see 5.4 chapter
4		Ready for operation signal light Signal light on when the machine is switched on and ready for operation
5		Welding procedure changeover switch -----MMA welding -----TIG welding
6		Welding current rotary knob Infinite welding current adjustment.
7		Adjusting guide for MMA welding current – table Recommended MMA welding current depending on electrode type and diameter.

5 Design and function

WARNING



Risk of injury from electrical voltage!

Contact with live parts, e.g. power connections, can be fatal!

- Observe the safety information on the first pages of the operating instructions!
- Commissioning must be carried out by persons who are specifically trained in handling power sources!
- Connect connection or power cables while the machine is switched off!

Read and observe the documentation to all system and accessory components!

5.1 Transport and installation

WARNING



Risk of accident due to improper transport of machines that must not be lifted!

Do not lift or suspend the machine! The machine can drop and cause injuries! The handles, straps or brackets are suitable for transport by hand only!

- The machine must not be suspended or lifted using a crane.

5.1.1 Machine cooling



Insufficient ventilation results in a reduction in performance and equipment damage.

- ***Observe the ambient conditions!***
- ***Keep the cooling air inlet and outlet clear!***
- ***Observe the minimum distance of 0.5 m from obstacles!***

5.1.2 Workpiece lead, general

CAUTION





Risk of burning due to incorrect welding current connection!

If the welding current plugs (machine connections) are not locked or if the workpiece connection is contaminated (paint, corrosion), these connections and leads can heat up and cause burns when touched!

- Check welding current connections on a daily basis and lock by turning to the right when necessary.
- Clean workpiece connection thoroughly and secure properly. Do not use structural parts of the workpiece as welding current return lead!

5.1.3 Ambient conditions

-  **The machine must not be operated in the open air and must only be set up and operated on a suitable, stable and level base!**
- **The operator must ensure that the ground is non-slip and level, and provide sufficient lighting for the place of work.**
 - **Safe operation of the machine must be guaranteed at all times.**

-  **Equipment damage due to contamination!**
Unusually high amounts of dust, acids, corrosive gases or substances can damage the machine (observe maintenance intervals > see 6.2 chapter).
- **Avoid large amounts of smoke, steam, oily fumes, grinding dust and corrosive ambient air!**

In operation

Temperature range of the ambient air:

- -25 °C to +40 °C (-13 °F to 104 °F)

Relative humidity:

- up to 50 % at 40 °C (104 °F)
- up to 90 % at 20 °C (68 °F)

Transport and storage

Storage in a closed room, temperature range of the ambient air:

- -30 °C to +70 °C (-22 °F to 158 °F)

Relative humidity

- up to 90 % at 20 °C (68 °F)

5.1.4 Transport belt

5.1.4.1 Adjusting the length of the carrying strap

To demonstrate adjustment, lengthening the strap is shown in the figure. To shorten, the strap's loops must be inched in the opposite direction.

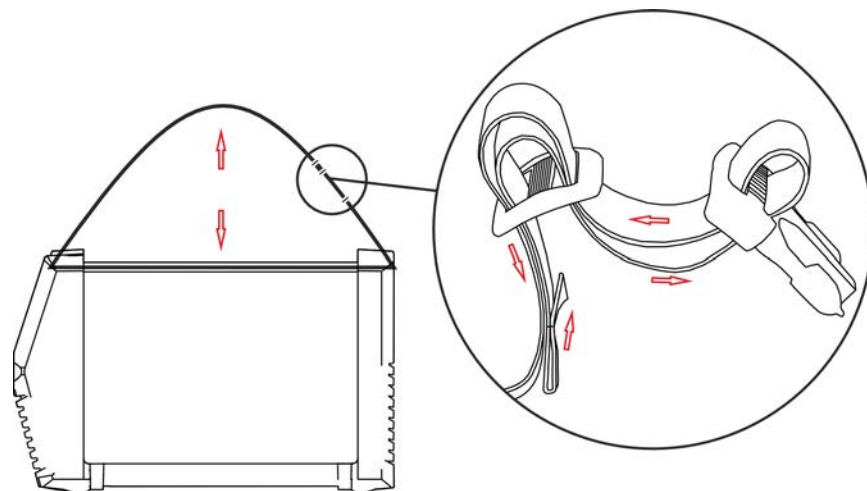

Figure 5-1

5.1.5 Notes on the installation of welding current leads

- Use an individual welding lead to the workpiece for each welding machine!

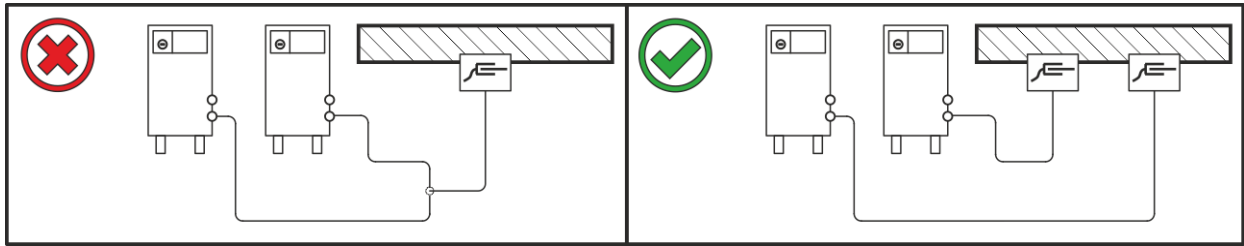

Figure 5-2

- Fully unroll welding current leads, torch hose packages and intermediate hose packages. Avoid loops!
- Always keep leads as short as possible!

Lay any excess cable lengths in meanders.

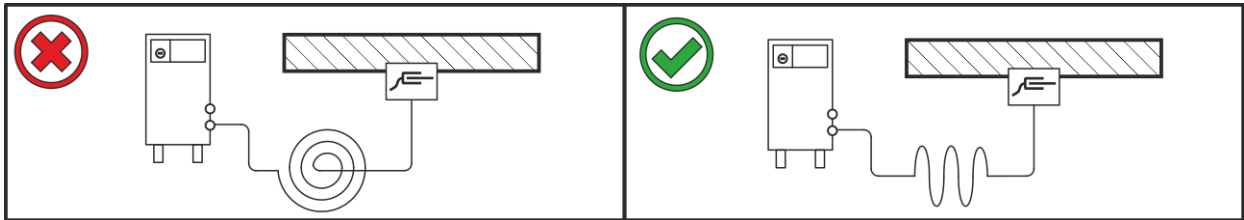

Figure 5-3

5.1.6 Stray welding currents

⚠ WARNING



Risk of injury due to stray welding currents!

Stray welding currents can destroy protective earth conductors, damage machines and electronic devices and cause overheating of components, leading to fire.

- Check that all welding current connections are firmly secured and electrical connections are in perfect condition.
- Set up, attach or suspend all conductive power source components such as casing, transport vehicles and crane frames so they are insulated.
- Do not place any other electronic devices such as drills or angle grinders on the power source, transport vehicle or crane frames unless they are insulated.
- Always put welding torches and electrode holders on an insulated surface when they are not in use.

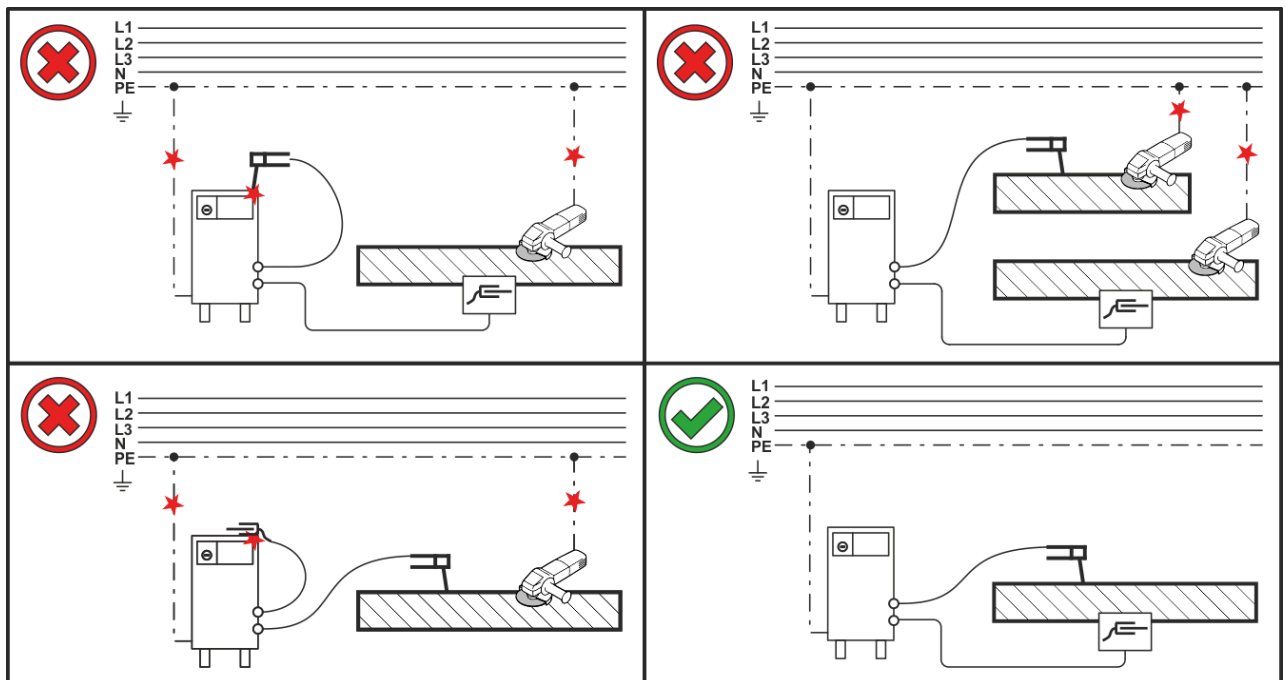

Figure 5-4

5.1.7 Mains connection

DANGER



Hazards caused by improper mains connection!

An improper mains connection can cause injuries or damage property!

- The connection (mains plug or cable), the repair or voltage adjustment of the device must be carried out by a qualified electrician in accordance with the respective local laws or national regulations!
- The mains voltage indicated on the rating plate must match the supply voltage.
- Only operate machine using a socket that has correctly fitted protective earth.
- Mains plug, socket and lead must be checked by a qualified electrician on a regular basis!
- When operating the generator, always ensure it is earthed as stipulated in the operating instructions. The network created must be suitable for operating machines according to protection class I.

5.1.7.1 Mains configuration



The machine may only be connected to a one-phase system with two conductors and an earthed neutral conductor.

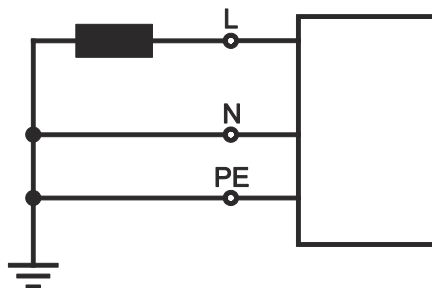

Figure 5-5

Legend

Item	Designation	Colour code
L	Outer conductor	brown
N	Neutral conductor	blue
PE	Protective conductor	green-yellow

- Insert mains plug of the switched-off machine into the appropriate socket.

5.2 MMA welding

5.2.1 Connecting the electrode holder and workpiece lead

⚠ CAUTION



Risk of crushing and burns!

When changing stick electrodes there is a risk of crushing and burns!

- Wear appropriate and dry protective gloves.
- Use an insulated pair of tongs to remove the used stick electrode or to move welded workpieces.

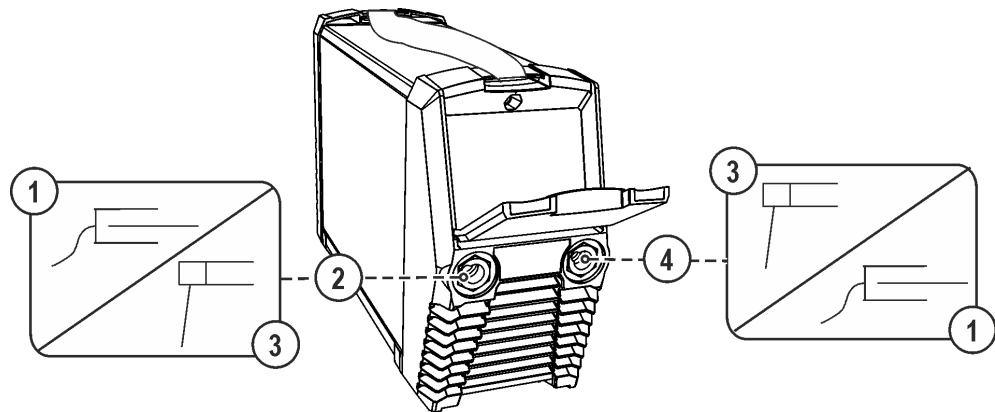

Figure 5-6

Item	Symbol	Description
1		Workpiece
2		Connection socket for "+" welding current Electrode holder or workpiece lead connection
3		Electrode holder
4		Connection socket, "-" welding current Workpiece lead or electrode holder connection

- Insert the electrode holder plug and workpiece lead into the welding current socket depending on application and lock in place by turning to the right. The corresponding polarity will be based on the information of the electrode manufacturer on the electrode packaging.

5.2.2 Welding task selection

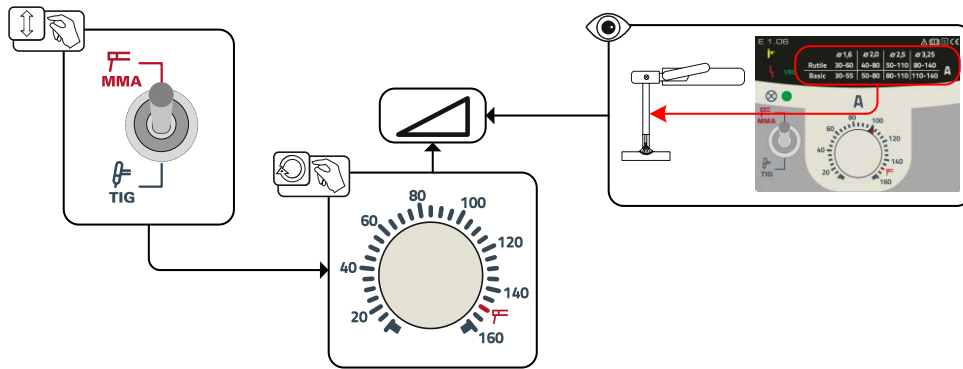

Figure 5-7

Type	Electrode type
Rutile	Rutile
Basic	Basic

5.2.3 Hotstart

The function hot start ensures a secure igniting of the arc and a sufficient heating to the still cold parent metal at the beginning of the welding process. The ignition takes place here with increased current (hot start current) over a certain time (hot start time).

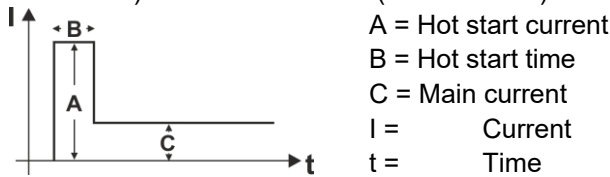
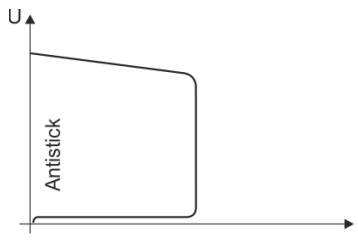

Figure 5-8

5.2.4 Arcforce

During the welding process, arcforce prevents the electrode sticking in the weld pool with increases in current. This makes it easier to weld large-drop melting electrode types at low current strengths with a short arc in particular.

5.2.5 Antistick



The Antistick feature prevents the electrode from annealing.

Should the electrode stick despite the Arcforce feature, the machine automatically switches to the minimum current within approx. one second. This prevents the electrode from annealing. Check the welding current setting and correct for the welding task in hand.

Figure 5-9

5.3 TIG welding

5.3.1 Connecting a TIG welding torch with rotating gas valve

Prepare welding torch according to the welding task in hand (see operating instructions for the torch).

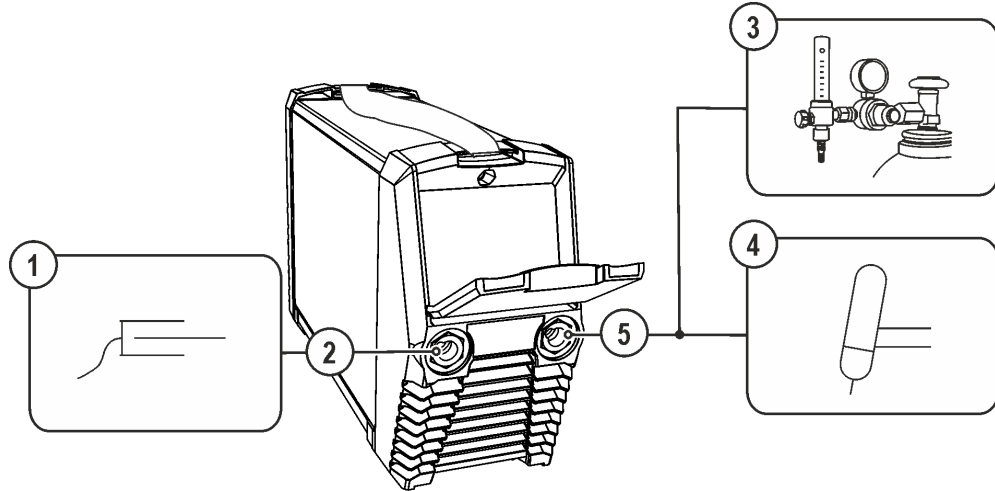

Figure 5-10

Item	Symbol	Description
1		Workpiece
2		Connection socket for "+" welding current Workpiece lead connection
3		Output side of the pressure regulator
4		Welding torch
5		Connection socket, "-" welding current Welding current lead connection for TIG welding torch

- Insert the welding current plug on the welding torch into the welding current connection socket and lock by turning to the right.
- Insert the cable plug on the work piece lead into the "+" welding current connection socket and lock by turning to the right.
- Screw the shielding gas hose of the welding torch to the pressure regulator outlet.

5.3.2 Shielding gas supply (shielding gas cylinder for welding machine)

WARNING



Risk of injury due to improper handling of shielding gas cylinders! Improper handling and insufficient securing of shielding gas cylinders can cause serious injuries!

- Place shielding gas cylinder into the designated holder and secure with fastening elements (chain/belt)!
- Attach the fastening elements within the upper half of the shielding gas cylinder!
- The fastening elements must tightly enclose the shielding gas cylinder!

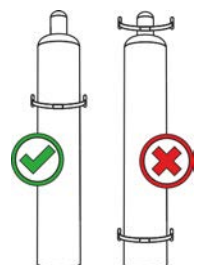

An unimpeded shielding gas supply from the shielding gas cylinder to the welding torch is a fundamental requirement for optimum welding results. In addition, a blocked shielding gas supply may result in the welding torch being destroyed.

- **All shielding gas connections must be gas tight.**

5.3.2.1 Pressure regulator connection

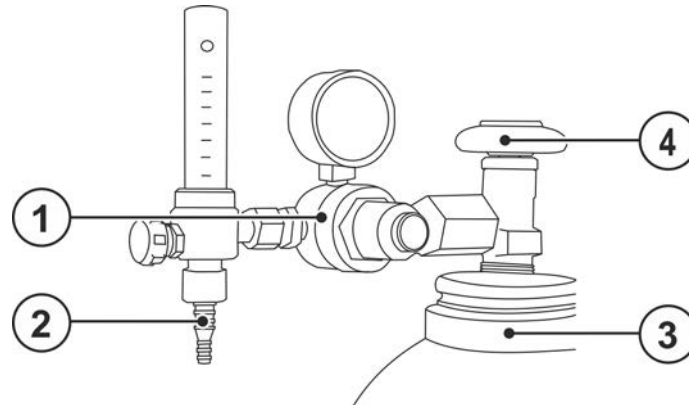

Figure 5-11

Item	Symbol	Description
1		Pressure regulator
2		Output side of the pressure regulator
3		Shielding gas cylinder
4		Cylinder valve

- Before connecting the pressure regulator to the gas cylinder, open the cylinder valve briefly to blow out any dirt.
- Tighten the pressure regulator screw connection on the gas bottle valve to be gas-tight.
- Screw the gas hose connection to the outlet side of the pressure regulator gas-tight.

5.3.3 Welding task selection

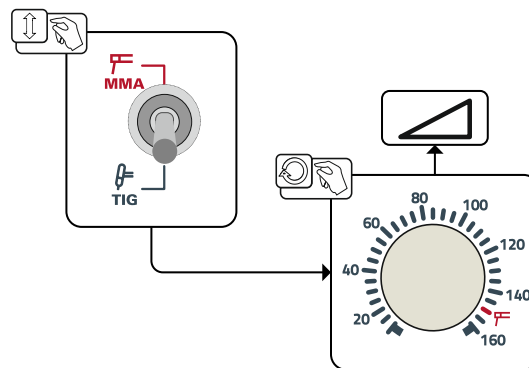

Figure 5-12

5.3.3.1 Gas test – setting the shielding gas volume

If the rotary gas valve is open, the shielding gas flows permanently from the welding torch (no adjustment with a separate gas valve). The rotary valve must be opened before each welding procedure and closed after each welding procedure.

If the shielding gas setting is too low or too high, this can introduce air to the weld pool and may cause pores to form. Adjust the shielding gas quantity to suit the welding task!

Rule of thumb for the gas flow rate:

Diameter of gas nozzle in mm corresponds to gas flow in l/min.

Example: 7mm gas nozzle corresponds to 7l/min gas flow.

- Slowly open the gas cylinder valve.
- Set the relevant gas quantity for the application on the pressure regulator.

5.3.4 Arc ignition

5.3.4.1 Liftarc

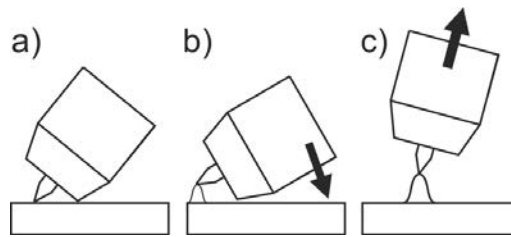

Figure 5-13

The arc ignites through contact with the workpiece:

- Carefully place the torch gas nozzle and tungsten electrode tip against the workpiece (lift arc current flows independent of the set main current)
- Angle the torch above the torch gas nozzle until the distance between electrode tip and workpiece is approx. 2–3 mm (arc ignites, current increases to the set main current).
- Lift the torch off and bring into normal position.

Complete the welding task: Remove the torch from the workpiece so that the arc extinguishes.

5.4 Voltage reducing device

Only machine variants with the (VRD/SVRD/AUS/RU) code are equipped with a voltage reduction device (VRD). The VRD is used for increased safety, especially in hazardous environments such as shipbuilding, pipe construction or mining.

A VRD is mandatory in some countries and required by many on-site safety instructions for power sources.

The VRD > see 4.3 chapter signal light is illuminated when the voltage reduction device is operating without fault and the output voltage is reduced to a value specified in the relevant standard (see technical data > see 8 chapter).

6 Maintenance, care and disposal

6.1 General

DANGER



Risk of injury due to electrical voltage after switching off!

Working on an open machine can lead to fatal injuries!

Capacitors are loaded with electrical voltage during operation. Voltage remains present for up to four minutes after the mains plug is removed.

1. Switch off machine.
2. Remove the mains plug.
3. Wait for at least 4 minutes until the capacitors have discharged!

WARNING



Improper maintenance, testing and repairs!

Maintenance, testing and repair of the machine may only be carried out by skilled and qualified personnel (authorised service personnel). A competent person is someone who, based on training, knowledge and experience, can recognize the hazards and possible consequential damage that may occur when testing power sources and can take the necessary safety precautions.

- Follow the maintenance instructions > see 6.2 chapter.
- If any of the test requirements below are not met, the unit must not be put back into operation until it has been repaired and tested again.

Repair and maintenance work may only be performed by qualified authorised personnel; otherwise the right to claim under warranty is void. In all service matters, always consult the dealer who supplied the machine. Return deliveries of defective equipment subject to warranty may only be made through your dealer. When replacing parts, use only original spare parts. When ordering spare parts, please quote the machine type, serial number and item number of the machine, as well as the type designation and item number of the spare part.

Under the specified ambient conditions and normal working conditions this machine is essentially maintenance-free and requires just a minimum of care.

Contamination of the machine may impair service life and duty cycle. The cleaning intervals depend on the ambient conditions and the resulting contamination of the machine. The minimum interval is every six months.

6.1.1 Cleaning

- Clean the outer surfaces with a moist cloth (no aggressive cleaning agents).
- Purge the machine venting channel and cooling fins (if present) with oil- and water-free compressed air. Compressed air may overspeed and destroy the machine fans. Never direct the compressed air directly at the machine fans. Mechanically block the fans, if required.
- Check the coolant for contaminants and replace, if necessary.

6.1.2 Dirt filter

When using a dirt filter, the cooling air throughput is reduced and the duty cycle of the machine is reduced as a result. The duty cycle decreases with the increasing contamination of the filter. The dirt filter must be removed at regular intervals and cleaned by blowing out with compressed air (depending on the level of soiling).

6.2 Maintenance work, intervals

6.2.1 Daily maintenance tasks

Visual inspection

- Mains supply lead and its strain relief
- Gas cylinder securing elements
- Check hose package and power connections for exterior damage and replace or have repaired by specialist staff as necessary!
- Gas tubes and their switching equipment (solenoid valve)
- Check that all connections and wearing parts are hand-tight and tighten if necessary.
- Check correct mounting of the wire spool.
- Wheels and their securing elements
- Transport elements (strap, lifting lugs, handle)
- Other, general condition

Functional test

- Operating, message, safety and adjustment devices (Functional test)
- Welding current cables (check that they are fitted correctly and secured)
- Gas tubes and their switching equipment (solenoid valve)
- Gas cylinder securing elements
- Check correct mounting of the wire spool.
- Check that all screw and plug connections and replaceable parts are secured correctly, tighten if necessary.
- Remove any spatter.
- Clean the wire feed rollers on a regular basis (depending on the degree of soiling).

6.2.2 Monthly maintenance tasks

Visual inspection

- Casing damage (front, rear and side walls)
- Wheels and their securing elements
- Transport elements (strap, lifting lugs, handle)
- Check coolant tubes and their connections for impurities

Functional test

- Selector switches, command devices, emergency stop devices, voltage reducing devices, message and control lamps
- Check wire guide elements (wire feed roll holder, wire feed nipple, wire guide tube) for tight fit. Recommendation for replacing the wire feed roll holder (eFeed) after 2000 hours of operation, see replacement parts).
- Check coolant tubes and their connections for impurities
- Check and clean the welding torch. Deposits in the torch can cause short circuits and have a negative impact on the welding result, ultimately causing damage to the torch.

6.2.3 Annual test (inspection and testing during operation)

A periodic test according to IEC 60974-4 "Periodic inspection and test" has to be carried out. In addition to the regulations on testing given here, the relevant local laws and regulations must also be observed.

For more information refer to the "Warranty registration" brochure supplied and our information regarding warranty, maintenance and testing at www.ewm-group.com!

6.3 Disposing of equipment



Proper disposal!

The machine contains valuable raw materials, which should be recycled, and electronic components, which must be disposed of.

- **Do not dispose of in household waste!**
- **Observe the local regulations regarding disposal!**
- According to European provisions (Directive 2012/19/EU on Waste of Electrical and Electronic Equipment), used electric and electronic equipment may no longer be placed in unsorted municipal waste. It must be collected separately. The symbol depicting a waste container on wheels indicates that the equipment must be collected separately.
This machine has to be disposed of, or recycled, in accordance with the waste separation systems in use.

According to German law (law governing the distribution, taking back and environmentally correct disposal of electrical and electronic equipment (ElektroG)), used machines are to be placed in a collection system separate from unsorted municipal waste. The public waste management utilities (communities) have created collection points at which used equipment from private households can be disposed of free of charge.

The deletion of personal data is the responsibility of the end user.

Lamps, batteries or accumulators must be removed and disposed of separately before disposing of the device. The type of battery or accumulator and its composition is marked on the top (type CR2032 or SR44). The following EWM products may contain batteries or accumulators:

- **Welding helmets**
Batteries or accumulators are easy to remove from the LED cassette.
- **Device controls**
Batteries or accumulators are located on the back of these in corresponding sockets on the circuit board and are easy to remove. The controls can be removed using standard tools.

Information on returning used equipment or collections can be obtained from the respective municipal administration office. Devices can also be returned to EWM sales partners across Europe.

Further information on the topic of the disposal of electrical and electronic equipment can be found on our website at: <https://www.ewm-group.com/de/nachhaltigkeit.html>.













7 Rectifying faults

All products are subject to rigorous production checks and final checks. If, despite this, something fails to work at any time, please check the product using the following flowchart. If none of the fault rectification procedures described leads to the correct functioning of the product, please inform your authorised dealer.

7.1 Machine faults (error messages)

- Document machine errors and inform service staff as necessary.

The following operating states are signalled when the machine is running:



Signal light status	Potential cause	Remedy
 Lit	 <p>Normal operating status The supply voltage is present, and the machine is switched on</p>	-
 Flashes	 <p>Mains overvoltage The supply voltage is too high (e.g., during generator operation)</p>	Check the mains supply voltage and correct it if necessary (replace the generator when necessary)
VRD Lit (Only for machine variant VRD)	 <p>Before welding</p>	-
	 <p>During TIG welding</p>	-
	 <p>During MMA welding</p>	Switch off the machine and contact Service.
VRD Not lit (Only for machine variant VRD)	 <p>Before welding The signal light does not come on before welding.</p>	Switch off the machine and contact Service.
	 <p>During TIG welding</p>	Switch off the machine and contact Service.
	 <p>During MMA welding</p>	-
 Lit	 <p>Excess temperature Machine duty cycle has been exceeded</p>	Place the welding torch / electrode holder on an insulated surface and allow the machine to cool while still switched on.

Key

	Normal operating status
	Fault state

7.2 Checklist for rectifying faults

The correct machine equipment for the material and process gas in use is a fundamental requirement for perfect operation!

Legend	Symbol	Description
		Fault/Cause
		Remedy

Excess temperature signal light illuminates

 Excess temperature, welding machine

 Allow the machine to cool down whilst still switched on





Functional errors

- ✓ All machine control signal lights are illuminated after switching on
- ✓ No machine control signal light is illuminated after switching on
- ✓ No welding power
 - ✘ Phase failure > check mains connection (fuses)
- ✓ Connection problems
 - ✘ Make control lead connections and check that they are fitted correctly.
- ✓ Loose welding current connections
 - ✘ Tighten power connections on the torch and/or on the workpiece
 - ✘ Tighten contact tip correctly

8 Technical data

Performance specifications and guarantee only in connection with original spare and replacement parts!

8.1 Pico 160

	MMA	TIG
Welding current (I ₂)	10 A to 150 A	10 A to 160 A
Welding voltage according to standard (U ₂)	20,4 V to 26,0 V	10,4 V to 16,4 V
Duty cycle DC at 40° C ^[1]		
30 %	-	160 A
35 %	150 A	-
60 %	120 A	130 A
100 %	100 A	
Mains voltage (Tolerance) / Frequency	1 x 230 V (-40 % to +15 %) / 50/60 Hz	
mains fuse ^[2]	1 x 20 A	
Continuous primary current (100 %)	19,6 A	11,8 A
Open circuit voltage (U ₀)	105 V	
Open circuit voltage (U _r) VRD AUS	33 V	
max. Connected load (S ₁)	7,3 kVA	4,9 kVA
Generator rating (Rec.)	9,9 kVA	6,6 kVA
Cos φ / efficiency	0,99 / 83 %	
Protection class / Overvoltage category	I / III	
Contamination level	3	
Insulation class / protection classification	H / IP 23	
Residual current circuit breaker	Type B (recommended)	
Noise level ^[3]	<70 dB(A)	
Ambient temperature	-25 °C to +40 °C	
Machine cooling / Torch cooling	Fan (AF) / gas	
Mains connection cable	H07RN-F3G2,5	
Workpiece lead	16 mm ²	
EMC class	A	
Test mark	 /  /  / 	
Standards used	See declaration of conformity (appliance documents)	
Dimensions (l x b x h)	370 x 129 x 236 mm 14.6 x 5.1 x 9.3 inch	
Weight	4,9 kg 10.8 lb	

^[1] Load cycle: 10 min. (60 % DC \triangleq 6 min. welding, 4 min. pause)

^[2] Safety fuses are recommended DIAZED xxA gG. When using automatic cutouts, the "C" trigger characteristic must be used.

^[3] Noise level during idle mode and operation under standard load according to IEC 60974-1 at the maximum operating point.

9 Accessories

9.1 Electrode holder

Type	Designation	Item no.
EH 16mm ² Ø13 mm 170A/60% 4m	Electrode holder with cable	094-005800-00000

9.2 Workpiece lead

Type	Designation	Item no.
WK16mm ² 170A/60% 4m/K	Workpiece lead	094-005801-00000

9.3 Welding torch

Type	Designation	Item no.
TIG 26 GDV 4m	TIG welding torch, rotary gas valve, gas-cooled, de-central	094-511621-00100
TIG 26 GDV 8m	TIG welding torch, rotary gas valve, gas-cooled, de-central	094-511621-00108

9.4 Shielding gas supply (shielding gas cylinder for welding machine)

Type	Designation	Item no.
Proreg Ar/CO2 230bar 15l D	Pressure regulator with manometer	394-008488-10015
Proreg Ar/CO2 230bar 30l D	Pressure regulator with manometer	394-008488-10030
Mod. 842 Ar/CO2 230bar 15l	Pressure regulator with manometer	394-002910-00015
GH 2X1/4" 2M	Gas hose	094-000010-00001
GH 2x1/4" 3m	Gas hose	094-000010-00003
GH 2X1/4" 5m	Gas hose	094-000010-00005
GH 2X1/4" 10 m	Gas hose	094-000010-00011
GH 2X1/4" 15m	Gas hose	094-000010-00015

9.5 Options

Type	Designation	Item no.
ON Filter Pico160	Air inlet dirt filter, retrofit option	092-003206-00000
ON Handle Pico 160	Grip, retrofit option	092-003205-00000
ON TG	Carrying strap	092-004310-00000

9.6 General accessories

Type	Designation	Item no.
SKGS 16A 250V CEE7/7, DIN 49440/441	Protective contact plug, solid rubber	094-001756-00000
ADAP CEE16/SCHUKO	Earth contact coupling/CEE16A plug	092-000812-00000

10 Service documents

WARNING



No improper repairs and modifications!

To prevent injuries and damage to the machine, only competent personnel (authorised service personnel) are allowed to repair or modify the machine.

Unauthorised manipulations will invalidate the warranty!

- Instruct competent personnel (authorised service personnel) to repair the machine.

10.1 Spare and replacement parts

Spare parts can be obtained from the relevant authorised dealer.

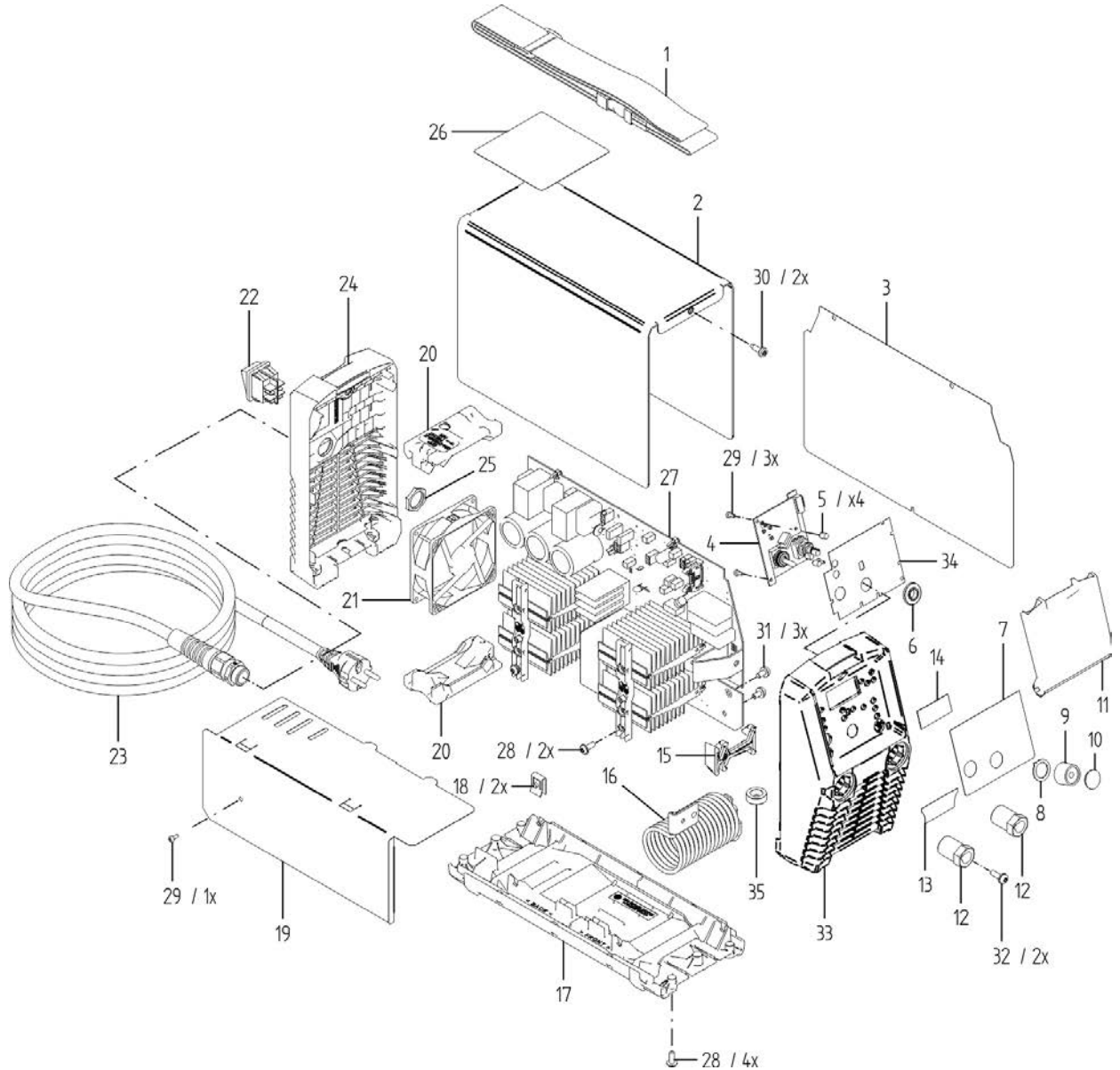

Figure 10-1

Position	Order number	Designation	Type
1	094-015236-E0501	Carrying strap	TG3-E
2	094-021818-E0501	Casing	BG BH276,5X201,5X124,2
3	094-021826-00000	Insulating paper	IP
4	040-001129-E0000	Printed circuit board (PCB) - replacement	E161
5	094-021994-00000	Light guide	LL8X6
6	094-023159-00001	Plastic insulation	KID
7	094-022197-00500	Adhesive film	KLF-E 1.06
8	074-000315-00002	Arrow indicator	ARROW INDICATOR 23MM
9	074-000315-00000	Rotary knob	KNOB 23MM
10	094-015043-00001	Rotary knob cover	KNOB COVER 23MM
11	094-021514-00000	Cover cap	KKS
12	094-021511-00001	Welding current socket	EB/35-50QMM
13	094-021795-00502	Adhesive film	LOGO/PLUS/MINUS
14	094-023137-00000	Cover plate	BAAF20X44,5
15	094-022172-00002	Spacer	KA57,3X33,5X17,5
16	092-003293-00000	Choke	WD/D=4/N=15
17	094-021509-00000	Casing, lower section	KBG
18	094-014311-00000	Sheet metal nut	M5/21X15X6
19	094-021508-00000	Insulating paper	IPL
20	094-015248-00001	Fan frame	S95X48X23
21	092-019418-00000	Fan	92X92X32
22	094-008045-10000	Mains switch	WS 250V/20A 2POLE
23	092-003003-00001	Mains cable	3X2.5QMM/3.5M SCHUKO
24	094-021478-00000	Casing, back panel	KRG
25	094-019537-00000	Nut	M20x1,5
26	094-022075-00500	Adhesive film	WP
27	040-001132-E0000	Inverter circuit board	DW160
28	094-012942-00000	Screw	M5X14/DELTA-PT-SCHRAUBE
29	094-010089-00000	Screw, Torx	M3X8-DG-SCHRAUBE
30	094-015135-00000	Screw	M5X16/KOMBITORX PLUS T25
31	094-021833-00000	Screw	M5X10/DIN6900-5 Z9/8.8/VERZ.
32	094-022122-00000	Clamping screw	M5X16/DIN6900-5 Z9/8.8/VERZ.
33	094-021477-00001	Casing, front section	KFG
34	094-023134-00000	Insulating paper	IP73,5X101
35	094-009542-00000	Toroidal core	T60006-E4019-W539

10.2 Circuit diagram

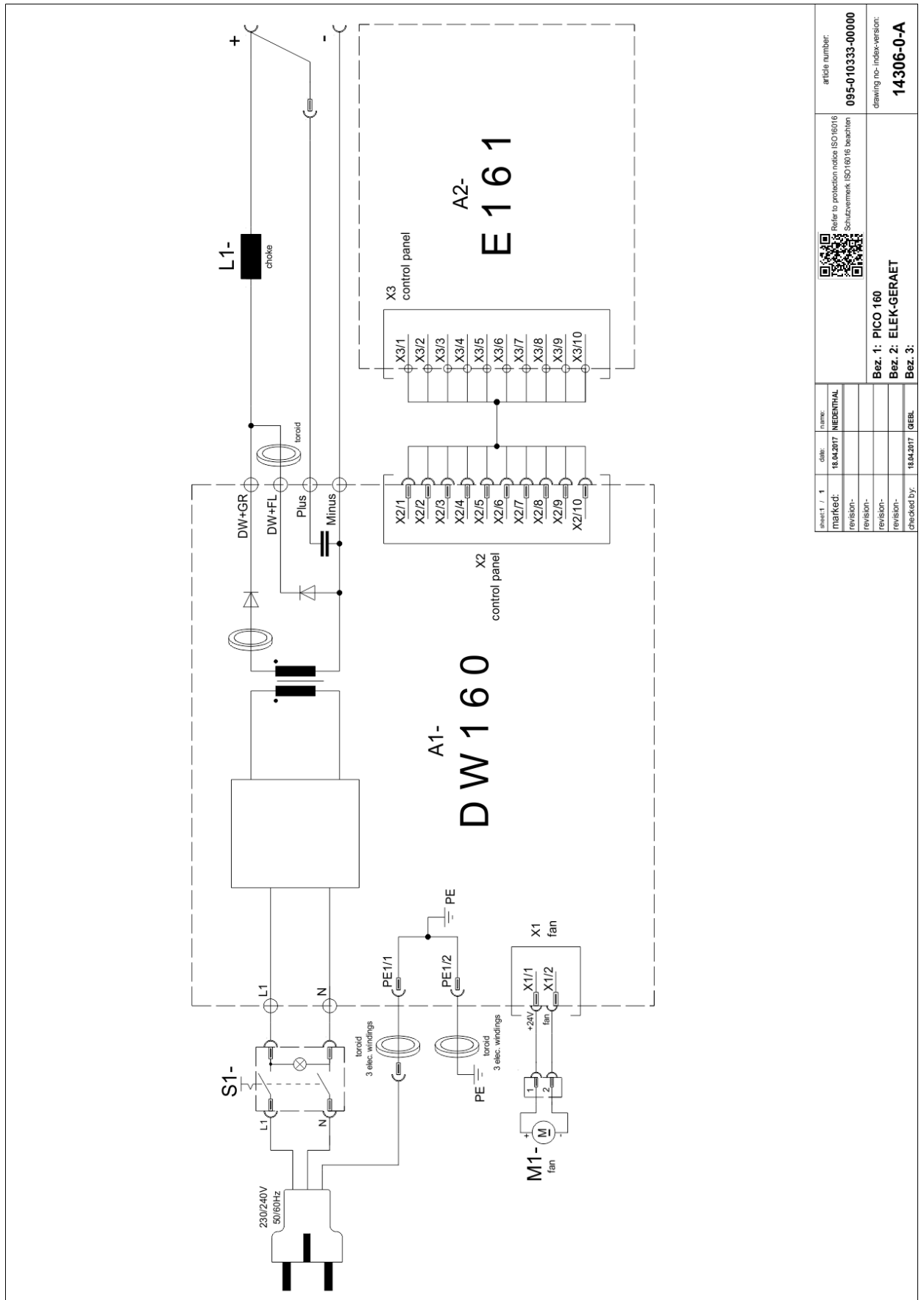

Figure 10-2

sheet / of	1 / 1	date:	18.04.2017	name:	NEBENTHAL	article number:	095-010333-00000
marked:						Refer to protection notice ISO 16016	
revision:						Schutzmerk ISO 16016 beachten	
revision:							
revision:							
checked by:		18.04.2017				Bez. 1: PICO 160 Bez. 2: ELEK-GERAET Bez. 3:	drawing no.-index-version: 14306-0-A

11 Appendix

11.1 Searching for a dealer

Sales & service partners
www.ewm-group.com/en/specialist-dealers



"More than 400 EWM sales partners worldwide"